



**WACKER
NEUSON**

5100029065	100
08.2018	

**Single Direction Plates
Vorwärtslaufende Platten
Planchas Vibradoras Unidirecc
Plaques Vibrantes à sens de ma**

VP1135Aw

**Parts Book
Ersatzteile
Lista de Repuestos
Liste de Pièces de Rechange**

www.wackerneuson.com

A nameplate listing the Model Number, Item Number, Revision, and Serial Number is attached to each unit. Please record the information found on this plate so it will be available should the nameplate become lost or damaged. When ordering parts or requesting service information, you will always be asked to specify the model, item number, revision number, and serial number of the unit.

Ein Typenschild mit Typ, Artikelnummer, Version und Maschinen-Nummer ist an jedem Gerät angebracht. Die Daten von diesem Schild bitte notieren, damit sie auch bei Verlust oder Beschädigung des Schildes noch vorhanden sind. Der Typ, die Artikel-Nummer, die Versions- Nummer und die Maschinen-Nummer sind bei der Ersatzteilbestellung oder Nachfragen bezüglich Service-Informationen stets erforderlich.

Una placa de identificación con el modelo, número de referencia, nivel de revisión y número de serie ha sido añadida en cada máquina. Favor de anotar los datos en la placa en caso de que la placa de identificación sea destruida o perdida. En todos los pedidos para repuestos necesita siempre el modelo, el número de referencia, el nivel de revisión y el número de serie de la máquina en cuestión.

Une plaque signalétique mentionnant le modèle, le numéro de référence, le niveau de révision et le numéro de série est fixée sur chaque machine. Veuillez noter les informations relevées sur cette plaque de façon à ce qu'elles soient toujours disponibles si la plaque signalétique venait à être perdue ou endommagée. Lorsque vous commandez des pièces détachées ou vous sollicitez des informations après-vente, on vous demandera toujours de préciser le modèle, le numéro de référence, le niveau de révision et le numéro de série de la machine.

***My machine's numbers are / Die Nummern meines Gerätes sind /
Los números de mi máquina son / Les numéros de ma machine son :***



Part Numbers appearing in boldface type are recommended spare parts. This means that these parts are subject to wear under normal operating conditions and may require periodic service or replacement. It is recommended that these items be stocked to meet the expected service requirements of this model. Actual stocking quantities of these and other parts used in more extensive repairs will depend on the service practices of each customer.

Bei den in den Ersatzteillisten fettgedruckten Nummern handelt es sich um empfohlene Ersatzteile. Dies bedeutet, daß diese Teile bei normalen Anwendungsbedingungen natürlicher Abnutzung ausgesetzt sind und gelegentlich ersetzt oder überarbeitet werden müssen. Es wird geraten, diese Teile auf Lager bereit zu haben, um für Service-Arbeiten an diesem Gerät vorbereitet zu sein. Lagerbestände für diese und andere Teile, welche für ausgiebigere Reparaturarbeiten benötigt werden, können je nach Service-Gewohnheiten der einzelnen Kunden variieren.

Los números de partes en negritas en las Listas Ilustradas de Partes son los repuestos recomendados, ésto quiere decir que estas partes se desgastarán bajo circunstancias de funcionamiento normales y pueden requerir servicio periódico o su reemplazo. Se recomienda que el cliente mantenga un abastecimiento adecuado de estas partes para poder satisfacer la demanda requerida por el servicio a la máquina. La cantidad de repuestos que el cliente necesitará para reparaciones dependerá de la póliza de servicio de cada cliente.

Les numéros de pièces imprimés en caractères gras dans les Listes des Pièces Détachées de ce manuel sont les pièces détachées recommandées par la Wacker. Cela veut dire que ces pièces sont sujettes à usure dans des conditions de travail normales et peuvent nécessiter de l'entretien ou leur remplacement. Nous recommandons que vous disposez d'un stock de ces pièces pour pouvoir satisfaire la demande d'entretien de cette machine. Le client doit décider lui-même de la quantité exacte de pièces de rechange qu'il disposera dans ses stocks.

Vibration Plate Vibrationsplatte Plancha Vibradora Plaque Vibrante	8
Vibration Plate Vibrationsplatte Plancha Vibradora Plaque Vibrante	10
Baseplate cpl. Untermasse kpl. Masa Inferior cpl. Masse Inferieure cpl.	12
Water System cpl. Berieselungsanlage kpl. Sistema de Rociado cpl. Système Diffuseur cpl.	14
Labels Aufkleber Calcomanías Autocollants	16
Engine Motor Motor Moteur	19
Starter Seilzugstarter Arrancador Démarreur	20
Fan hood Gebläseabdeckung Tapa de ventilador Couvercle du sys. de vent.	22
Carburetor Vergaser Carburador Carburateur	24
Air Cleaner Luftfilter Filtro del Aire Filtre à Air	28
Muffler Schalldämpfer Silenciador Silencieux	30
Fuel Tank Kraftstofftank Depósito de Combustible Réservoir à Essence	32
Fly wheel Schwungrad Volante Volant	34
Cylinder head Zylinderkopf Culata Culasse	36

Indice**Table des matières**

Ignition coil Zündspule Bobina de encendido Bobine d'allumage	38
Governor Regler Regulador Régulateur	40
Cylinder housing Zylindergehäuse Carcasa de cilindro Carter cylindre	42
Crankcase cover Kurbelgehäuseabdeckung Cubierta da la caja de manivel Couvercle carter de manivelle	44
Crankshaft Kurbelwelle Cigüeñal Vilebrequin	46
Piston Kolben Pistón Piston	48
Camshaft Nockenwelle Arbol de levas Arbre à cames	50
Labels Aufkleber Calcomanias Autocollants	52
Accessoires Zubehör Accesorios Accessories	55
Urethane Pad Kit Gleitvorrichtung Placa de Deslizamiento Jeu de Tapis en Polyuréthane	56
Water System cpl. Berieselungsanlage kpl. Sistema de Rociado cpl. Système Diffuseur cpl.	58

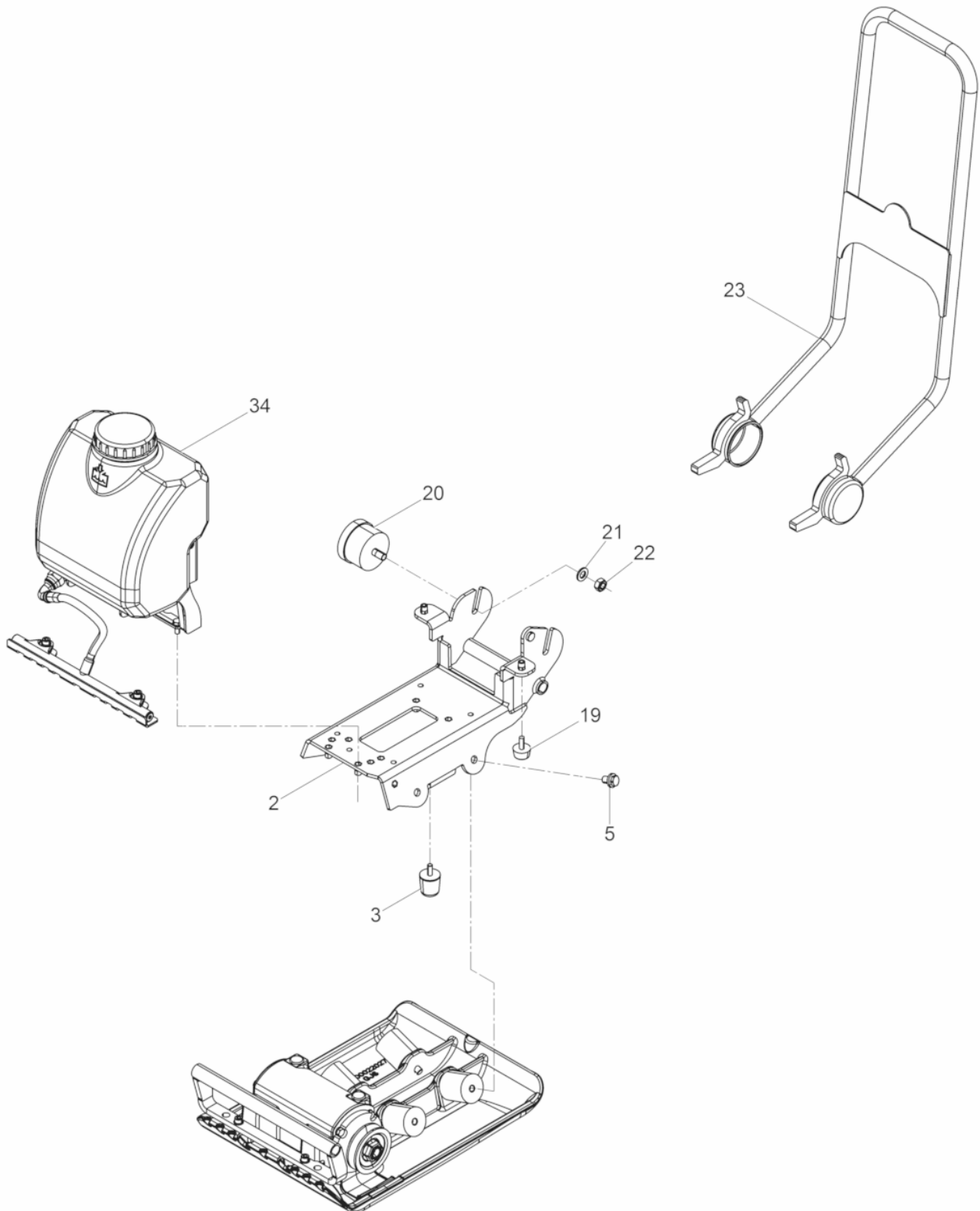

Ref. Pos.	Part No. Artikel Nr.	Qty. St.	Description Beschreibung	Descripción Description	Measurem./Abm.	Norm
					Torque/Drehm.	Sealant Schmierstoff
2	5100037176	1	Upper Mass Obermasse	Masa Superior Masse Superieure		
3	5100016327	1	Shockmount Anschlagpuffer	Amortiguador Silentbloc	35 x 40	
5	5100024478	4	corrugated-head screw Sicherheitsschraube	Tornillo Vis	M12x 16 86Nm/63ft.lbs	
19	5100016317	2	Shockmount Anschlagpuffer	Amortiguador Silentbloc	30 x 15	
20	0106557	2	Shockmount Gummi-Metall-Puffer	Tope caucho-metal Tampon métallique oscillant		
21	0010620	2	Flat washer Scheibe	Arandela Rondelle	12	ISO7090
22	0010884	2	Hexagon nut Sechskantmutter	Tuerca hexagonal Écrou hexagonal	M12	DIN934
23	5100028877	1	Shackle Bügel	Estribo Étrier		
34	5100029069	1	Spinkler system cpl. Berieselung kpl.	Systema de Riego cpl. Installation d'arrosage cpl.		

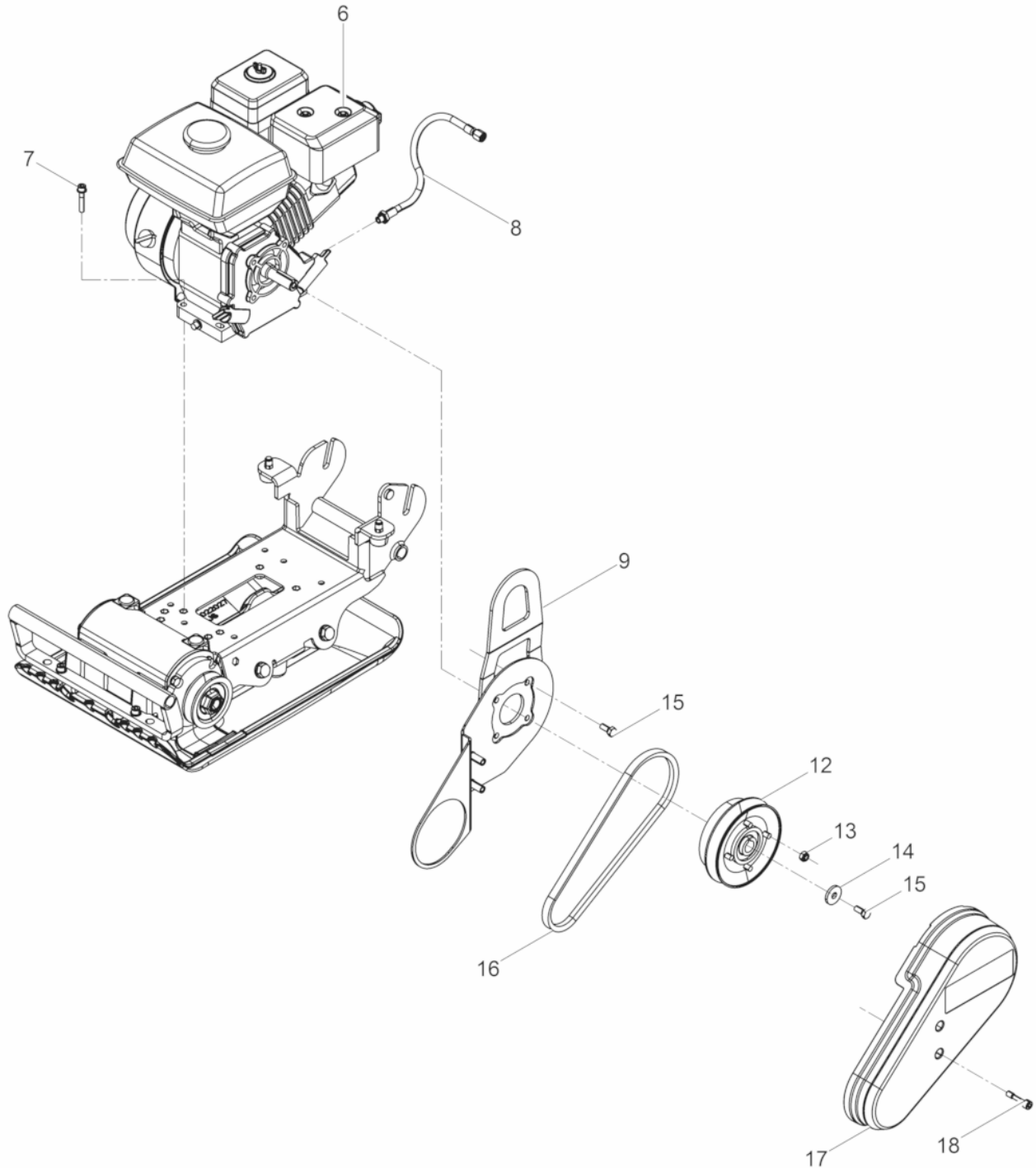

Ref. Pos.	Part No. Artikel Nr.	Qty. St.	Description Beschreibung	Descripción Description	Measurem./Abm.	Norm
					Torque/Drehm.	Sealant Schmierstoff
6	5100031153	1	Gas Engine Benzinmotor	Motor a Gasolina Moteur à Essence		
7	5100036848	4	Cheese head screw Zylinderschraube	Tornillo cilíndrico Vis à tête cylindrique	25Nm/18ft.lbs	
8	0129265	1	Hose pipe Schlauchleitung	Conducto flexible Conduite flexible		
9	5100018408	1	Guard plate Keilriemenschutzblech	Chapa protectora Tôle de protection		
12	5100016313	1	Centrifugal clutch Fliehkraftkupplung	Embrague centrífugo Embrayage centrifuge		
13	0033356	4	Hexagon nut Sechskantmutter	Tuerca hexagonal Écrou hexagonal		
14	5100016321	1	Washer Scheibe	Arandela Rondelle		
15	0026169	5	Hexagonal head cap screw Sechskantschraube	Tornillo hexagonal Vis à tête hexagonale	5/16in-24UNF-2A 18Nm/13ft.lbs	k3/4in
16	5100044733	1	V-belt Keilriemen	Correa en V Courroie		
17	5100018416	1	Belt guard Riemenschutz	Protección de la polea Protection de courroie		
18	0216658	2	Screw Dünnschaftschraube	Tornillo Vis	M 8x 38	

Baseplate cpl.
Untermasse kpl.
Masa Inferior cpl.
Masse Inferieure cpl.

VP1135Aw

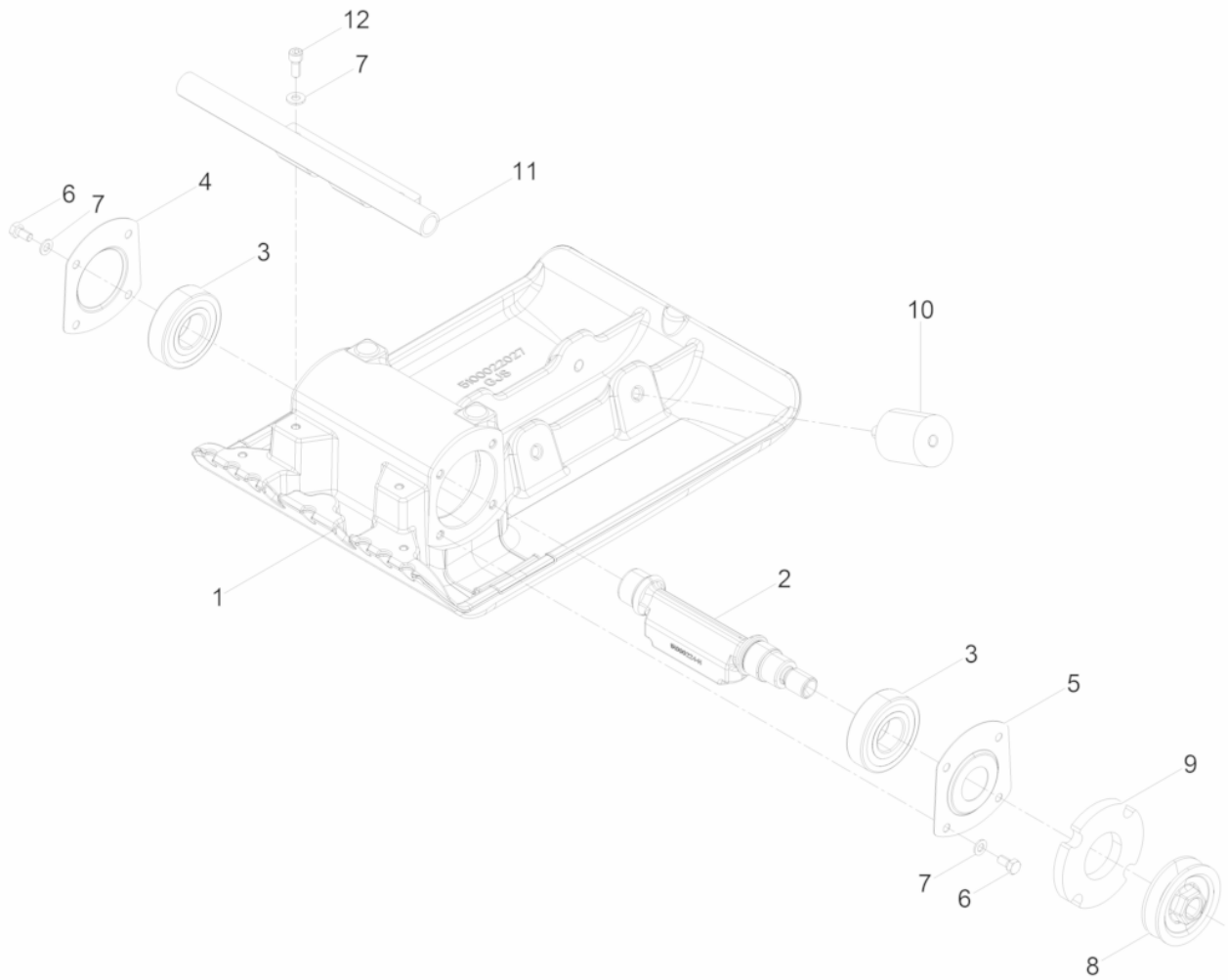

Ref. Pos.	Part No. Artikel Nr.	Qty. St.	Description Beschreibung	Descripción Description	Measurement./Abm.	Norm
					Torque/Drehm.	Sealant Schmierstoff
1	5100028870	1	Baseplate Untermasse	Masa inferior Masse inferieure		
2	5100022440	1	Eccentric shaft Unwuchtwelle	Eje de la masa excéntrica Arbre portant l'excentrique		
3	5100025039	2	Grooved ball bearing Rillenkugellager	Rodamiento a bolas Roulement rainuré à billes		
4	5100025229	1	Bearing bracket Lagerschild	Placa de cojinete Bride palier		
5	5100025240	1	Bearing bracket Lagerschild	Placa de cojinete Bride palier		
6	0012361	8	Hexagonal head cap screw Sechskantschraube	Tornillo hexagonal Vis à tête hexagonale	M8 x 16 25Nm/18ft.lbs	DIN933
7	0010622	10	Flat washer Scheibe	Arandela Rondelle		
8	5100022460	1	V-belt pulley Keilriemenscheibe	Polea en V Poulie à courroie		
9	5100028871	1	Gasket Dichtung	Junta Joint		
10	5100016316	4	Shockmount Gummi-Metall-Puffer	Tope caucho-metal Tampon metallique oscillant	50x55	
11	5100028962	1	Handle Handgriff	Empuñadura Poignée		
12	0011540	2	Cheese head screw Zylinderschraube	Tornillo cilíndrico Vis à tête cylindrique	M8 x 35 25Nm/18ft.lbs	ISO4762

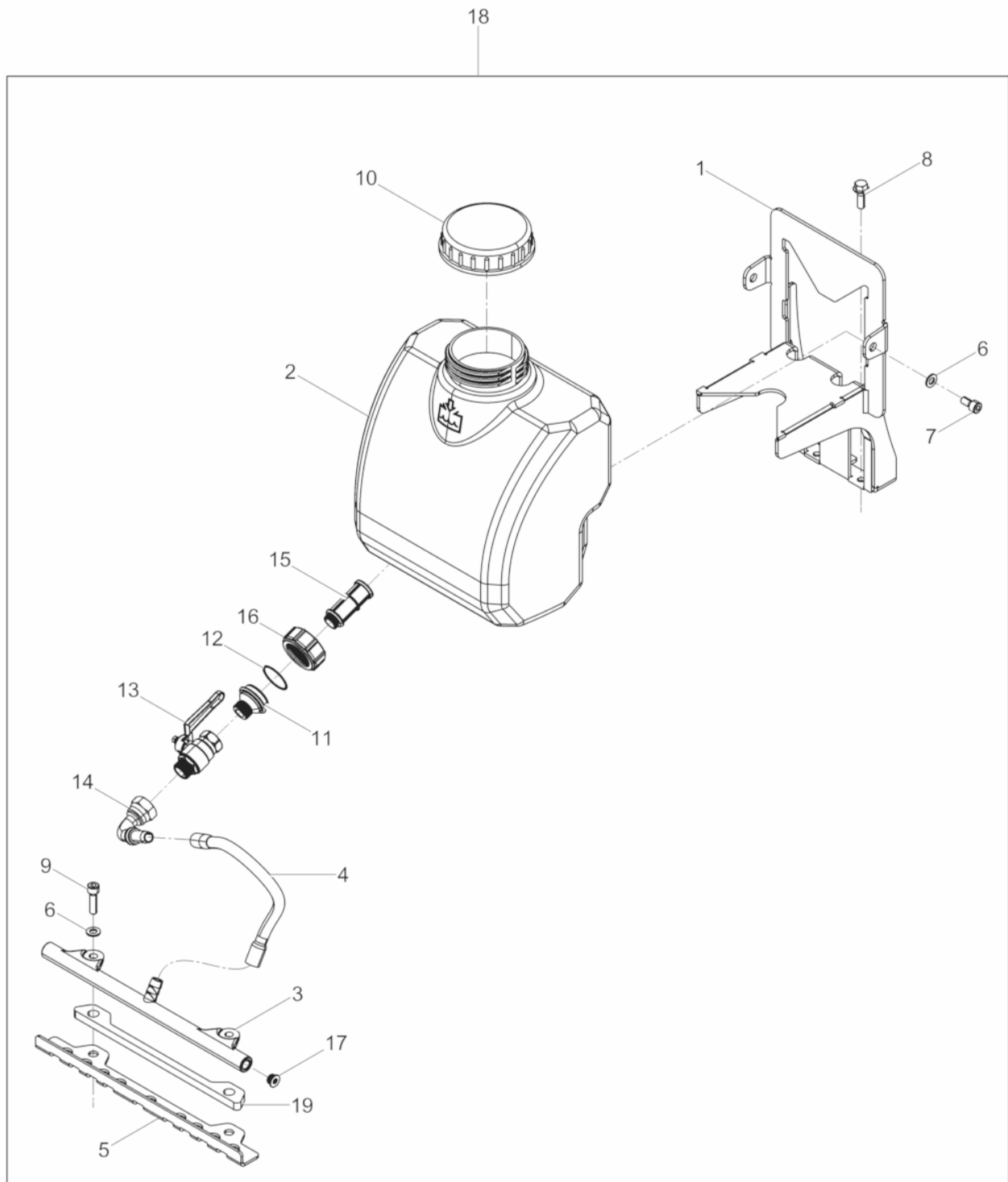

Ref. Pos.	Part No. Artikel Nr.	Qty. St.	Description Beschreibung	Descripción Description	Measurem./Abm.	Norm
					Torque/Drehm.	Sealant Schmierstoff
1	5100028973	1	Bracket Wassertankhalterung	Soporte Équerre		
2	5100028898	1	Watertank Wassertank	Tanque de agua Reservoir à eau		
3	5100030374	1	Spinkler system Berieselung	Systema de riego Installation d'Arrosage		
4	5100036378	1	Water Hose Wasserschlauch	Manguera de agua Tuyau d'eau		
5	5100028917	1	Guard plate Schutzblech	Chapa protectora Tôle de protection		
6	0010622	4	Flat washer Scheibe	Arandela Rondelle		
7	0011544	2	Cheese head screw Zylinderschraube	Tornillo cilíndrico Vis à tête cylindrique	M8 x 16 25Nm/18ft.lbs	ISO4762
8	5100035900	4	Hexagonal head cap screw Sechskantschraube	Tornillo hexagonal Vis à tête hexagonale		
9	0011541	2	Cheese head screw Zylinderschraube	Tornillo cilíndrico Vis à tête cylindrique		
10	0068351	1	Screwed cover Schraubdeckel	Tapa roscable Couvercle fileté		
11	5100028921	1	Flange Flansch	Brida Bride		
12	5100028922	1	O-ring O-Ring	Anillo-O Bague-O		
13	5100028889	1	Ball valve Kugelhahn	Llave esférica Robinet à boisseau spherique		
14	5100028897	1	Connector Pressnippel	Conector Connexion		
15	5100028890	1	water filter Wasserfilter	filtro de agua Filtre		
16	5100028920	1	Cap screw Überwurfmutter	Tuerca de racor Écrou d'accouplement		
17	5100029615	2	Plug Einschraubstopfen	Tapón Bouchon		
18	5100029069	1	Spinkler system cpl. Berieselung kpl.	Systema de Riego cpl. Installation d'arrosage cpl.		
19	5100028918	1	Plate Blech	Chapa Tôle		

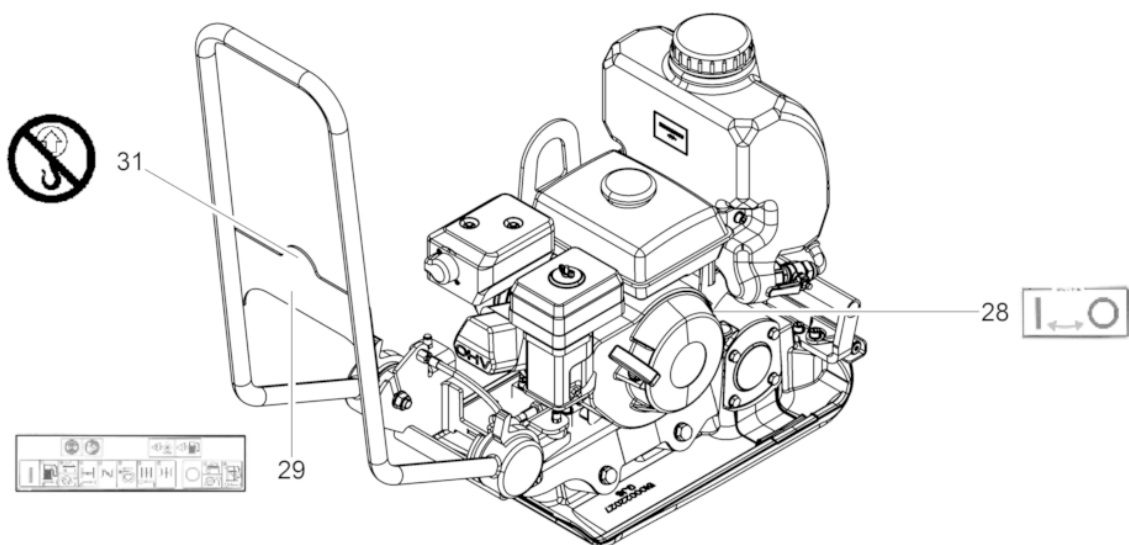
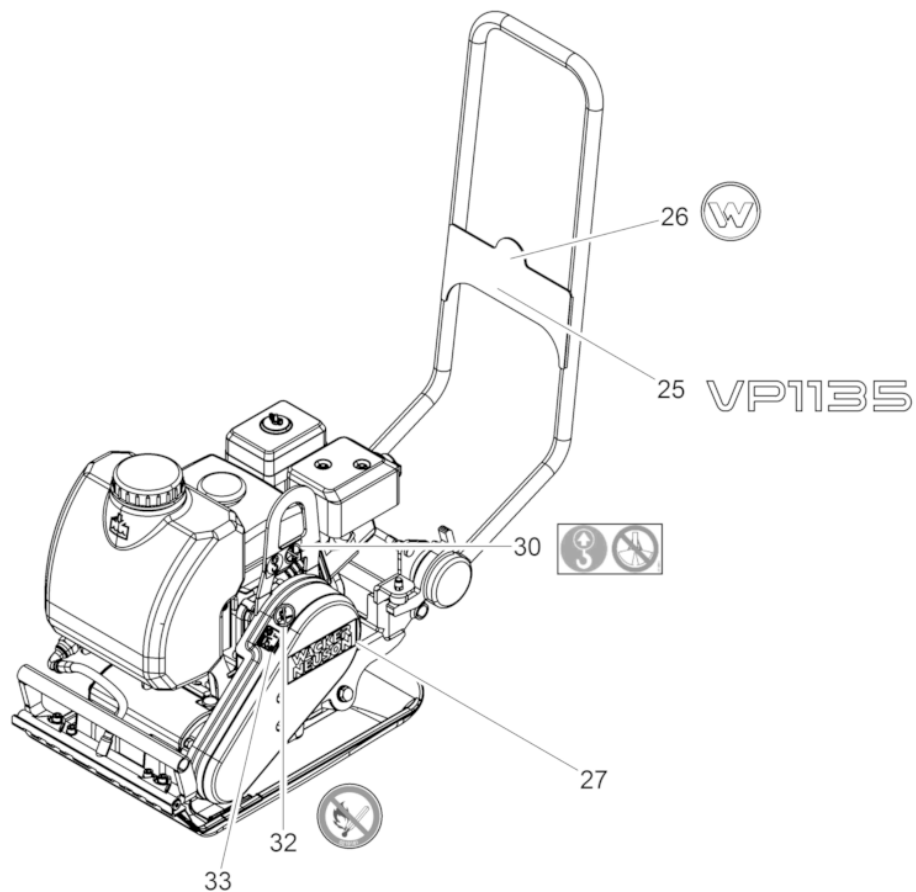

Ref. Pos.	Part No. Artikel Nr.	Qty. St.	Description Beschreibung	Descripción Description	Measurement./Abm.	Norm
					Torque/Drehm.	Sealant Schmierstoff
25	5100021995	1	Type Label Aufkleber-Typ	Tipo etiqueta autoadhesiva Autocollant de type		
26	0222085	1	Label Symbol Aufkleber Symbol	Calcomanía Símbolo Autocollant Symbole		
27	0213181	1	Label logo Aufkleber Logo	Calcomanía Insigniaipo Autocollant Logo	40mm	
28	5100016455	1	Label (ON-OFF) Aufkleber (ON-OFF)	Calcomanía (ON-OFF) Autocollant (ON-OFF)		
29	5100018423	1	Label Aufkleber	Calcomanía Autocollant		
30	0219260	1	Labels Aufkleber	Calcomanías Autocollants		
31	0220000	1	Instruction Label Aufkleber-Warnhinweis	Calcomanía-Indicación Autocollant avec Indication		
32	0219181	1	Labels Aufkleber	Calcomanías Autocollants		
33	0208195	1	Decal-Sound Power Level Aufkleber-Schalleistungspegel	Etiqueta autoadhesiva-nivel de potencia acúëstica Autocollante-niveau sonore		



**WACKER
NEUSON**

**Engine
Motor
Motor
Moteur**

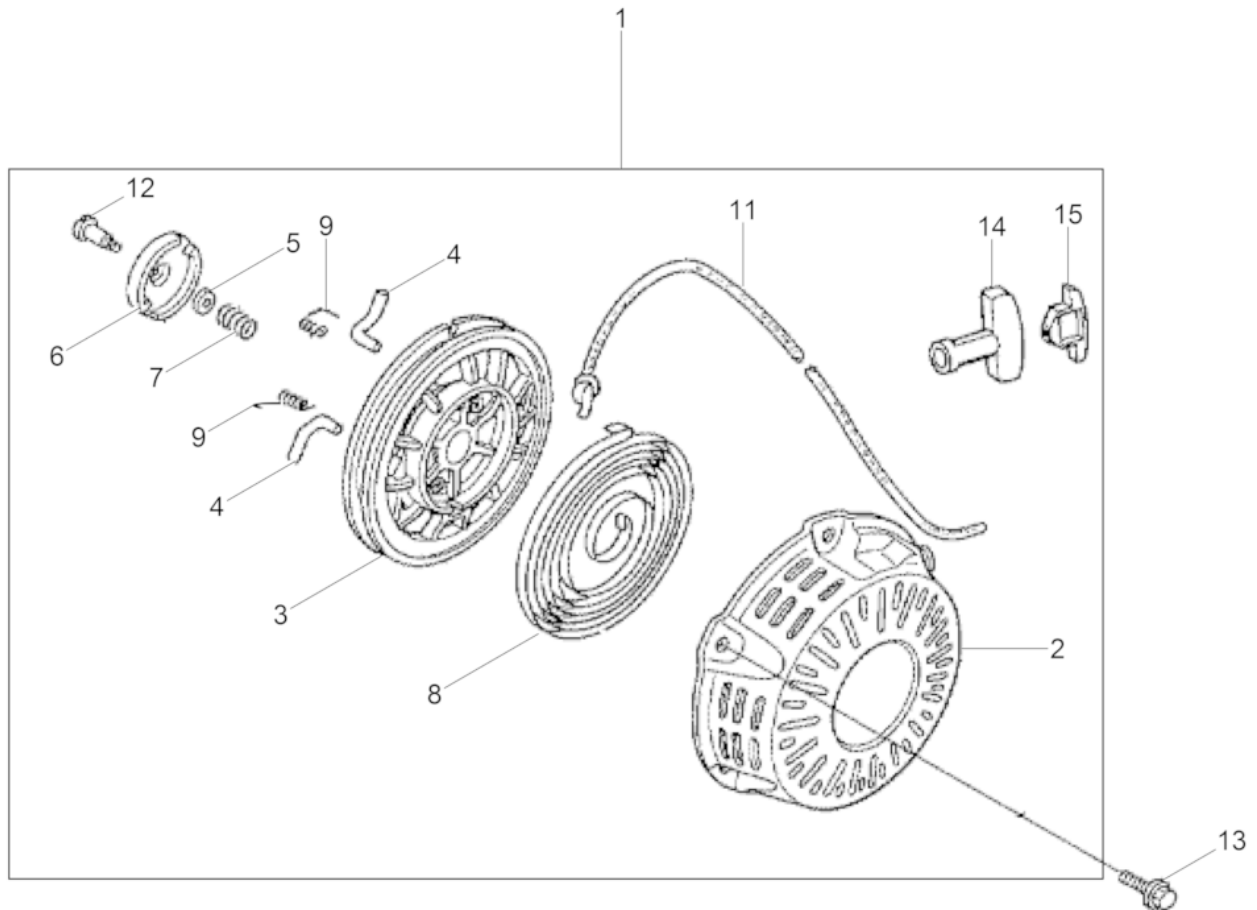

Ref. Pos.	Part No. Artikel Nr.	Qty. St.	Description Beschreibung	Descripción Description	Measurement/Abm.	Norm
					Torque/Drehm.	Sealant Schmierstoff
1	5100005305	1	Starter cpl. US (black) Seilzugstarter kpl. US(schwarz)	Arrancador cpl. US (negro) Démarrreur cpl. US (noir)		
1	5100005367	1	Starter cpl. (black) Seilzugstarter kpl. (schwarz)	Arrancador cpl. (negro) Démarrreur cpl. (noir)		
2	5100005307	1	Housing cpl. (black) Gehäuse kpl. (schwarz)	Carcasa cpl. (negro) Carter cpl. (noir)		
3	5100005308	1	Rope disc Seilscheibe	Polea para cuerda Poulie de démarrage		
4	0160527	2	Ratchet Ratsche	Trinquete Cliquet		
5	0160748	1	Friction Plate Reibplatte	Placa de Fricción Plaque à Friction		
6	0160745	1	Guide Führung	Guía Guide		
7	0160747	1	Friction spring Reibfeder	Resorte de Fricción Ressort à Friction		
8	0081777	1	Spring Feder	Resorte Ressort		
9	0207990	2	Spring Schenkelfeder	Resorte Ressort		
11	0081781	1	Rope Starterseil	Cuerda Corde		
12	0207991	1	Screw Schraube	Tornillo Vis		
13	0081750	3	Screw Schraube	Tornillo Vis	M6 x 8	
14	5100005309	1	Starter handle US Startergriff US	Empuñadura del starter US Poignée du lanceur US		
14	5100005413	1	Starter handle Startergriff	Empuñadura del starter Poignée du lanceur		
15	5100005310	1	Covering Abdeckung	Cubierta Couverture		

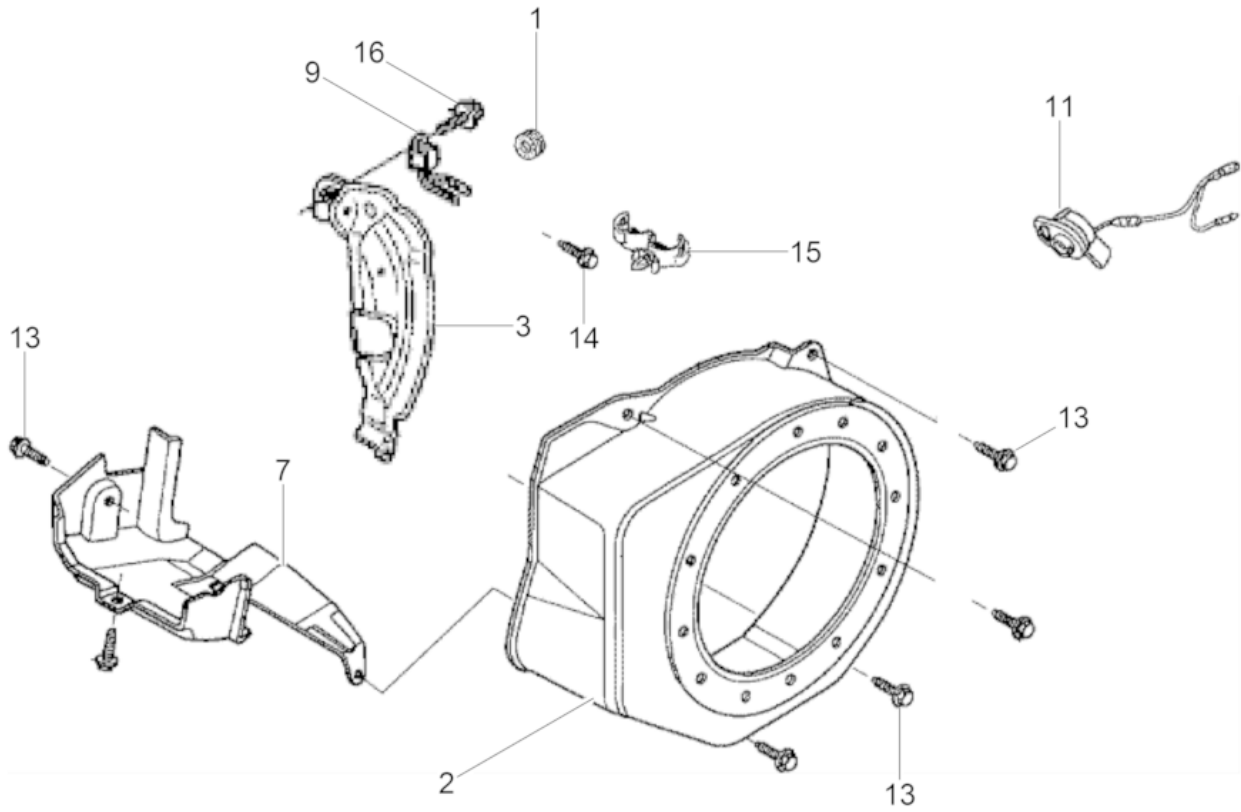

Ref. Pos.	Part No. Artikel Nr.	Qty. St.	Description Beschreibung	Descripción Description	Measurement./Abm.	Norm
					Torque/Drehm.	Sealant Schmierstoff
1	0070979	1	Grommet Tülle	Ojal Passe-fil	0,315in	
2	0117150	1	Blower Housing Lüftergehäuse	Cubierta Bouclier		
3	0153137	1	Plate Platte	Placa Plaque		
7	0153139	1	Duct Luftleitblech	Conducto de aire Canal d'air		
9	5100005313	1	Oil Sensor Ölsensor	Alerta de Aceite Alerte d'Huile		
11	0162682	1	Switch assembly Schalter kpl.	Interruptor compl. Interrupteur compl.		
13	0053990	6	Screw Schraube	Tornillo Vis	M6 x 12 10Nm/7ft.lbs	
14	0071055	1	Screw Schraube	Tornillo Vis	M6 x 20 10Nm/7ft.lbs	
15	0151700	1	Clamp Schelle	Abrazadera Attache		
16	0081750	1	Screw Schraube	Tornillo Vis	M6 x 8	

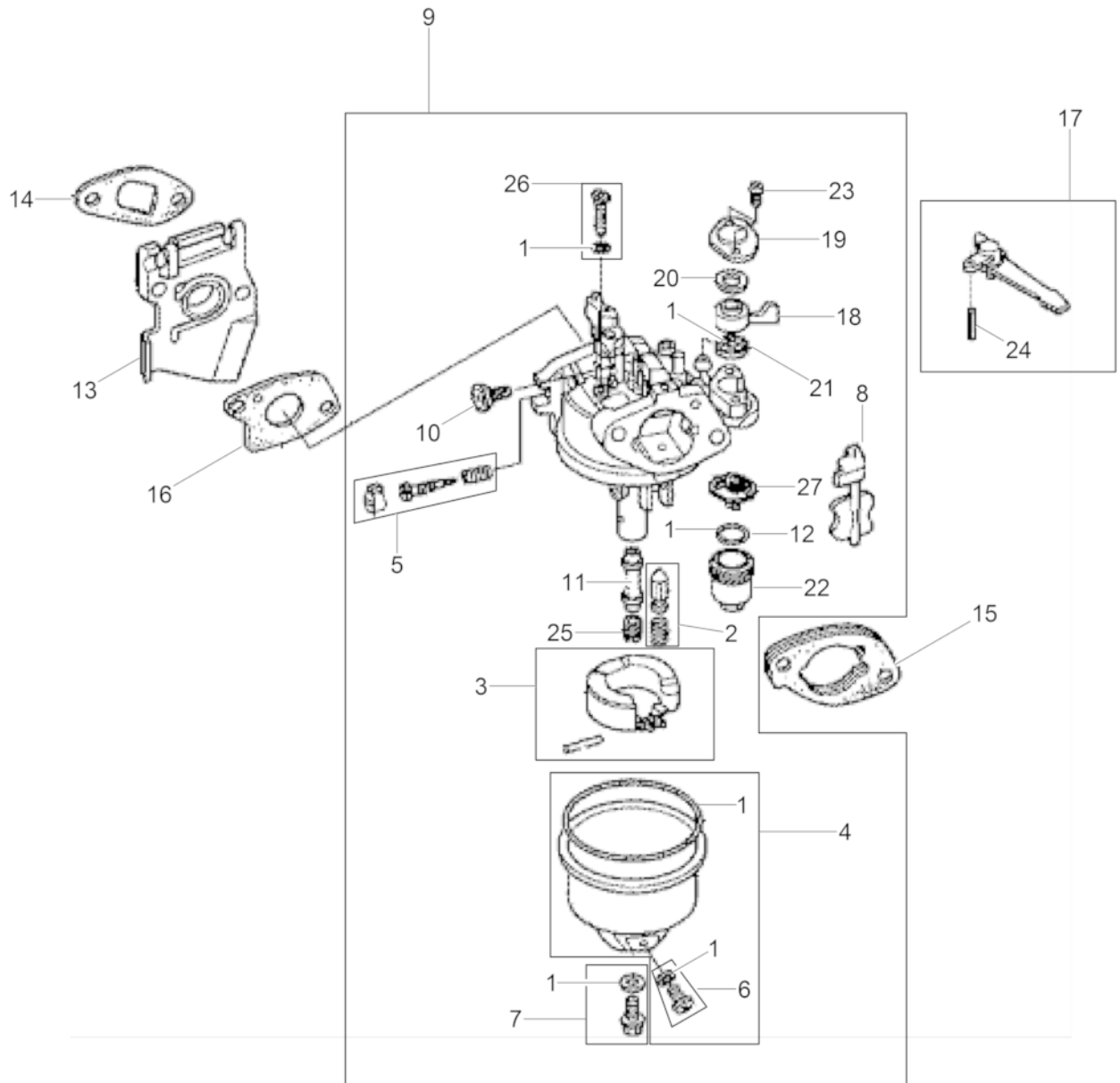

Ref. Pos.	Part No. Artikel Nr.	Qty. St.	Description Beschreibung	Descripción Description	Measurem./Abm.	Norm
					Torque/Drehm.	Sealant Schmierstoff
1	0072781	1	Set-gaskets Dichtungssatz	Juego de juntas Jeu de joints		
2	0071022	1	Set-float valve Schwimmernadel kpl.	Válvula de flotador Pointeau du carburateur		
3	0209764	1	Set-carburetor float Schwimmer kpl.	Juego de flotador Jeu de flotteur		
4	5100005314	1	Float housing Schwimmergehäuse	Cámara de flotador Cuve à niveau constant		
5	0089286	1	Setscrew Gewindestift	Tornillo Vis		
6	5200000430	1	Screw w/washer Schraube mit Scheibe	Tornillo con arandela Vis avec rondelle		
7	5200000431	1	Screw w/washer Schraube mit Scheibe	Tornillo con arandela Vis avec rondelle		
8	0071025	1	Set-engine choke Chokesatz	Juego de estrangulador Jeu d'étrangleur		
9	0406688	1	Carburetor cpl. Vergaser kpl.	Carburador compl. Carbureteur compl.		
10	0071018	1	Throttle stop screw Anschlagschraube	Tornillo de tope Vis		
11	5100031331	1	Main jet Hauptdüse	Gicleur principal Gicleur prinzipal		
12	0125839	1	O-Ring O-Ring	Anillo-O Joint torique		
13	0071010	1	Insulator Isolator	Aislador Isolant		
14	0081794	1	Gasket Dichtung	Junta Joint		
15	0071015	1	Spacer Distanzstück	Espaciador Pièce d'écartement		
16	0081762	1	Gasket Dichtung	Junta Joint		
17	0071013	1	Choke control lever Chokehebel	Palanca estranguladora Levier d'étrangleur		
18	0150266	1	Fuel valve lever Kraftstoffhahn	Palanca Levier		
19	0073269	1	Plate Platte	Placa Plaque		
20	0073270	1	Spring washer Federscheibe	Arandela elástica Rondelle à ressort		
21	0073272	1	Gasket Dichtung	Junta Joint		
22	0071023	1	Fuel filter Kraftstofffilter	Filtro de combustible Filtre à carburant		
23	5100005317	2	Screw Kegelkopfschraube 3x6	Tornillo Vis	3x6	
24	0071014	1	Pin Stift	Pasador Goupille	2 x 12	
25	0153140	1	Main jet Hauptdüse	Chicler principal Gicleur principal	55	

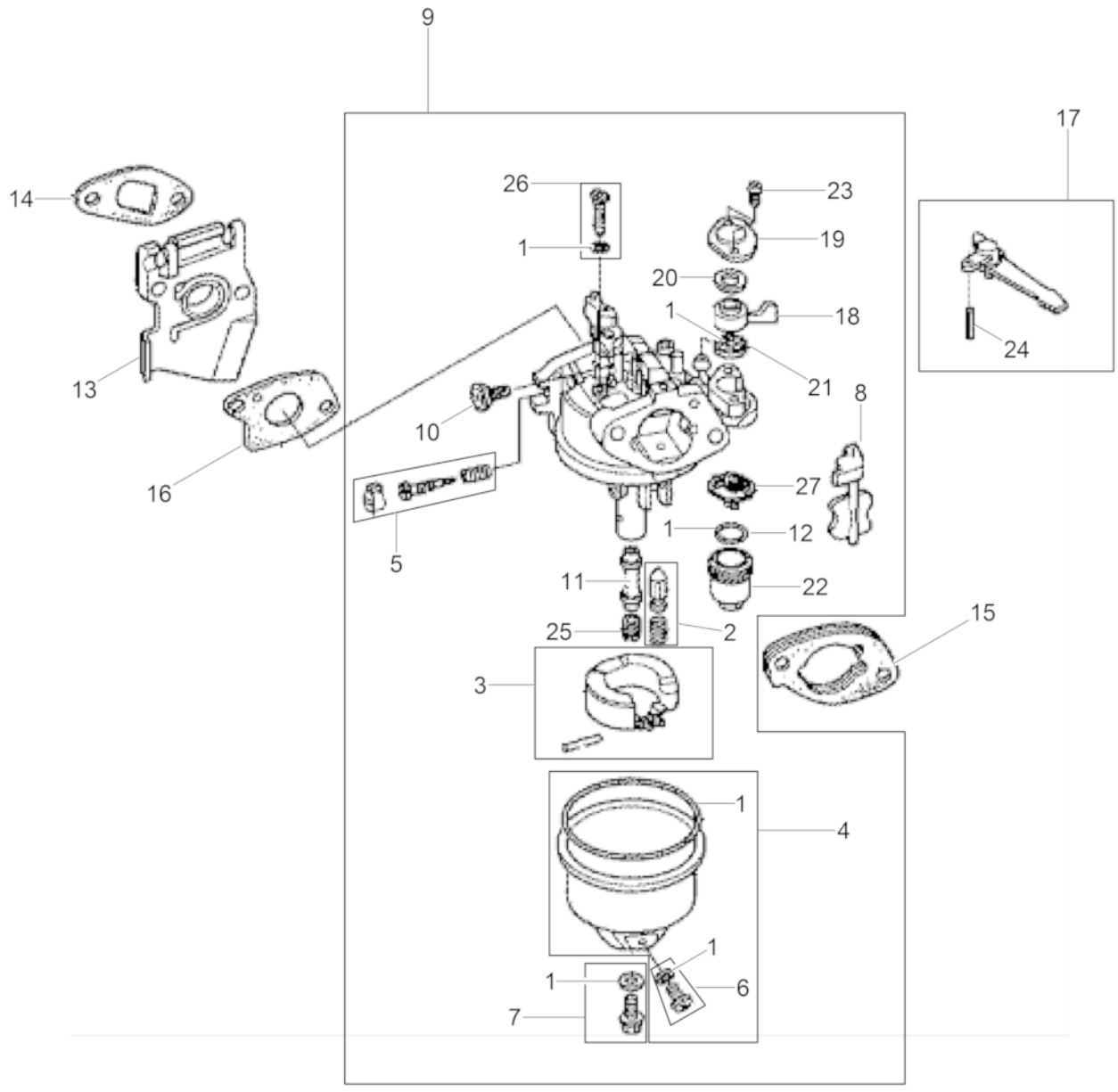

Ref. Pos.	Part No. Artikel Nr.	Qty. St.	Description Beschreibung	Descripción Description	Measurement/Abm.	Norm
					Torque/Drehm.	Sealant Schmierstoff
25	5100029308	1	Main jet 60 Hauptdüse 60	Chicler principal 60 Gicleur principal 60		
25	5100029307	1	Main jet 58 Hauptdüse 58	Chicler principal 58 Gicleur principal 58		
26	0071016	1	Pilot jet Leerlaufdüse	Chicler ralenti Gicleur de ralenti	35	
27	5100000396	1	Filter Filter	Filtro Filtre		

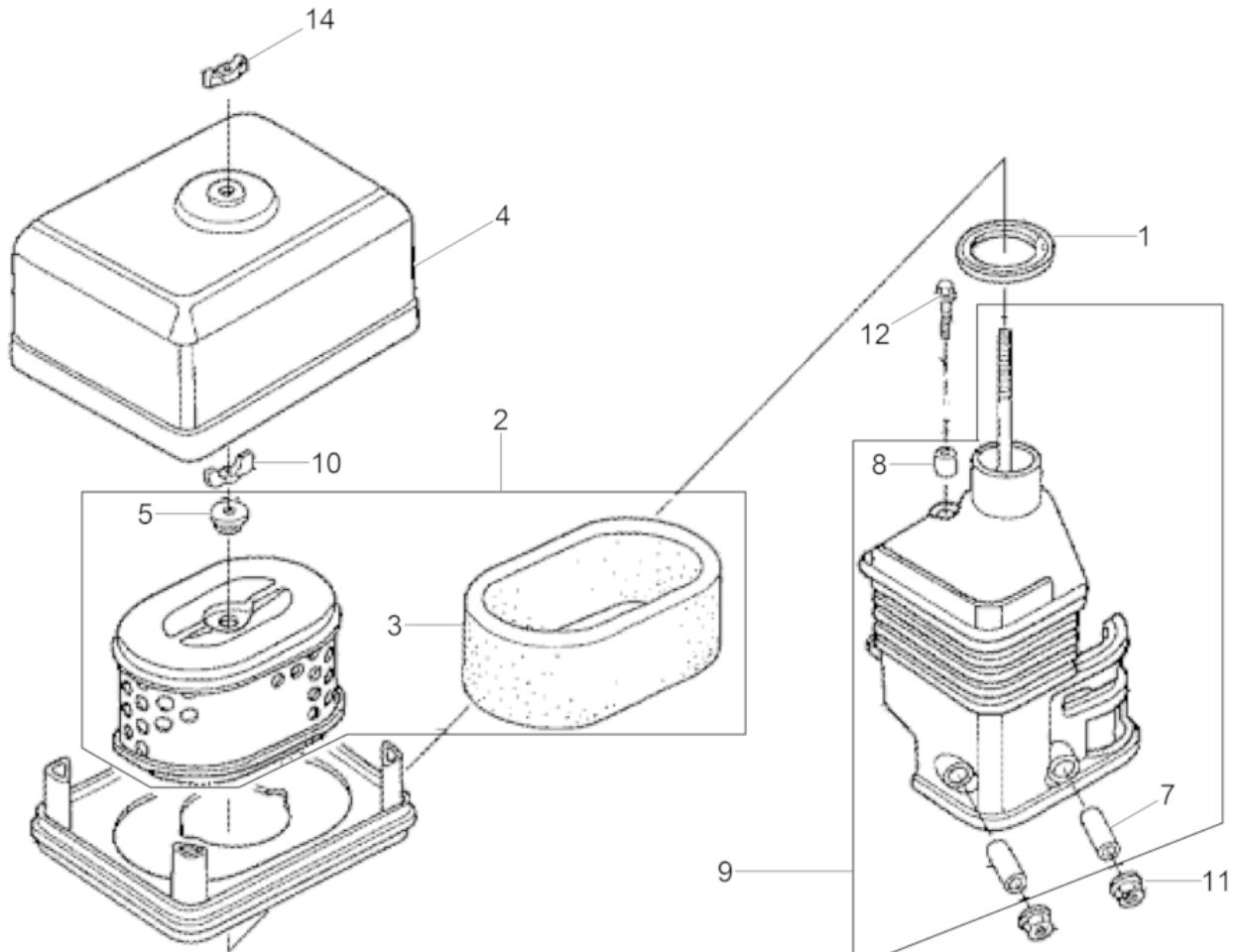

Ref. Pos.	Part No. Artikel Nr.	Qty. St.	Description Beschreibung	Descripción Description	Measurement/Abm.	Norm
					Torque/Drehm.	Sealant Schmierstoff
1	0071032	1	Gasket Dichtung	Junta Joint		
2	5100031332	1	Air filter insert Luftfiltereinsatz	Inserto para filtro de aire Garniture filtre à air		
3	0076941	1	Prefilter element Vorfilter	Elemento del prefiltro Élément du prénettoyeur		
4	5000406689	1	Cover Deckel	Tapa Couvercle		
5	0072343	1	Grommet Tülle	Ojal Passe-fil		
7	0081746	2	Sleeve Hülse	Collar Douille		
8	0071035	1	Sleeve Hülse	Manguito Douille		
9	5000406690	1	Elbow cpl. Krümmer kpl.	Codo compl. Coude compl.		
10	0071621	1	Wing nut Flügelmutter	Tuerca mariposa Ecrou papillon	M6	
11	0071056	2	Nut Mutter	Tuerca Ecrou	M6	
12	5100003499	1	Flange screw Flanschschraube 6X20	Tornillo de brida Vis de bride	6x20	
14	5100031333	1	Wing nut Flügelmutter	Tuerca mariposa Écrou papillon		

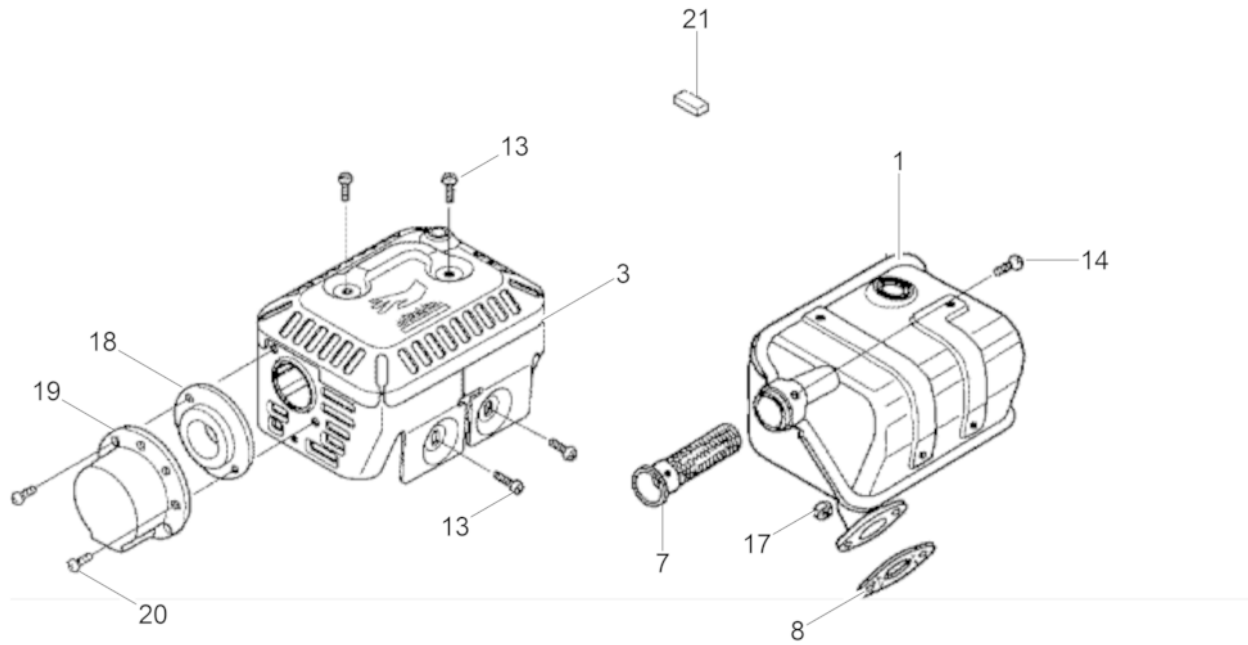

Ref. Pos.	Part No. Artikel Nr.	Qty. St.	Description Beschreibung	Descripción Description	Measurement./Abm.	Norm
					Torque/Drehm.	Sealant Schmierstoff
1	5000406644	1	Muffler Auspufftopf	Silenciador Pot d'échappement		
3	5000406646	1	Guard Schutz	Protector Protection		
7	0071075	1	Spark arrester Funkenfänger	Parachispas Pare-étincelles		
8	0216516	1	Gasket Dichtung	Junta de estanqueidad Garniture		
13	0071070	4	Screw Schraube	Tornillo Vis	M5 x 8	
14	0150916	1	Screw Schraube	Tornillo Vis	M4x6	
17	5100003492	2	Hexagon nut Sechskantmutter M8	Tuerca hexagonal Écrou hexagonal	M8	
18	0081756	1	Exhaust baffle Aufpuffleitblech	Deflector de escape Déflecteur d'échappement		
19	0081757	1	Guide Führung	Guía Guide		
20	0209783	2	Self-tapping screw Schneidschraube	Tornillo autorroscante Vis autotaraudeuse	4 x 8	
21	0070999	1	Fitting key Passfeder	Chaveta Clavette	4,78 x 38	

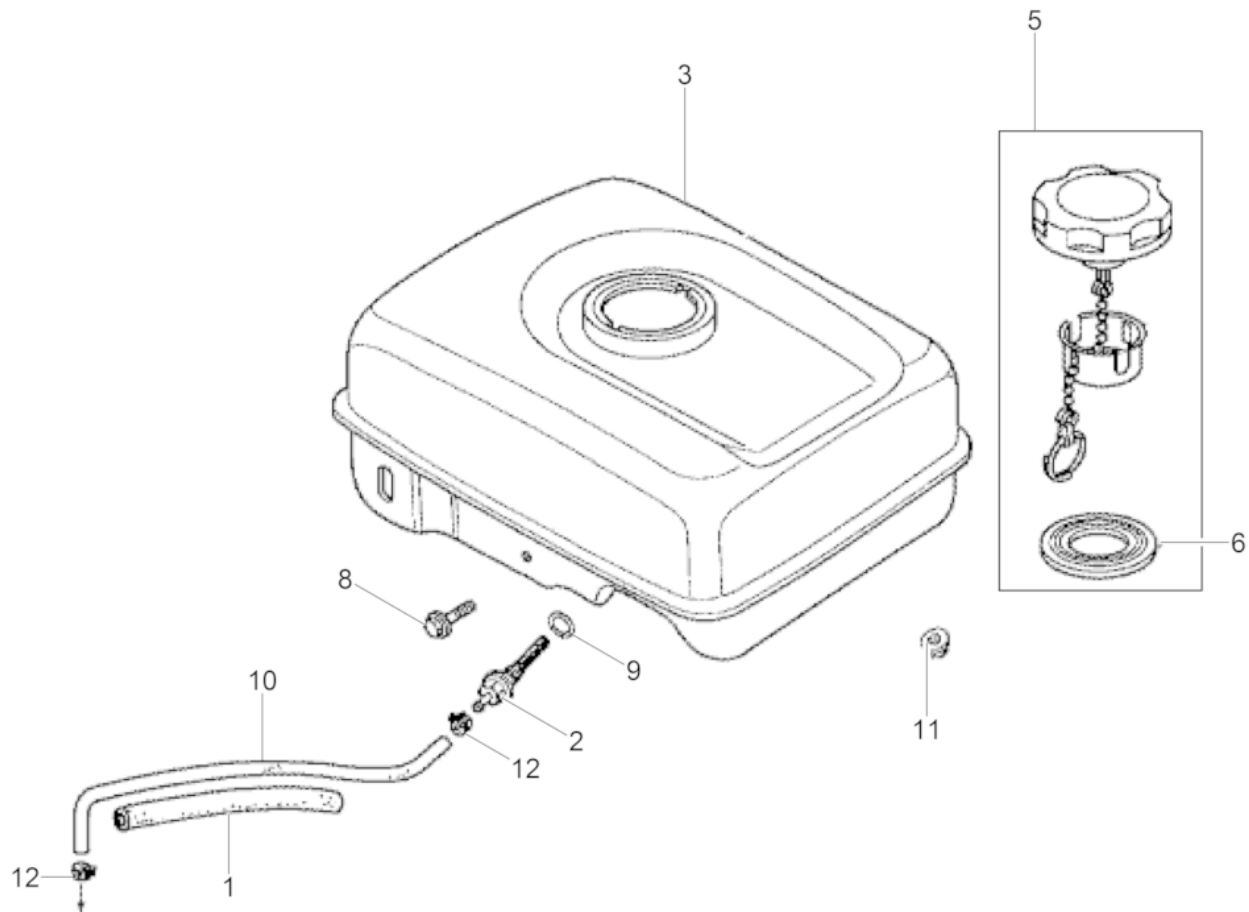

Ref. Pos.	Part No. Artikel Nr.	Qty. St.	Description Beschreibung	Descripción Description	Measurement./Abm.	Norm
					Torque/Drehm.	Sealant Schmierstoff
1	0081764	1	Protective hose Schlauchstück	Manguera Tuyau		
2	5100000395	1	Connection Verbindungsstück	Conexión Connexion		
3	5000406692	1	Fuel tank Kraftstofftank	Depósito de combustible Réservoir de carburant		
5	5100005356	1	Tank cover cpl. Tankdeckel kpl.	Tapa de tanque cpl. Couvercle du reservoir cpl.		
6	0209770	1	Gasket Dichtung	Junta de estanqueidad Garniture		
8	0209771	1	Flange Bolt Flanschbolzen	Tornillo de Perno Vis de Boulon	6x29	
9	0208616	1	O-Ring O-Ring	Anillo-O Joint torique	14M	
10	5000217760	1	Fuel hose Kraftstoffleitung	Manguera de combustible Tuyau de carburant	4,50 x 140	
11	0071056	2	Nut Mutter	Tuerca Ecrou	M6	
12	0208617	2	Clamp Rohrschelle	Abrazadera Agrafe		

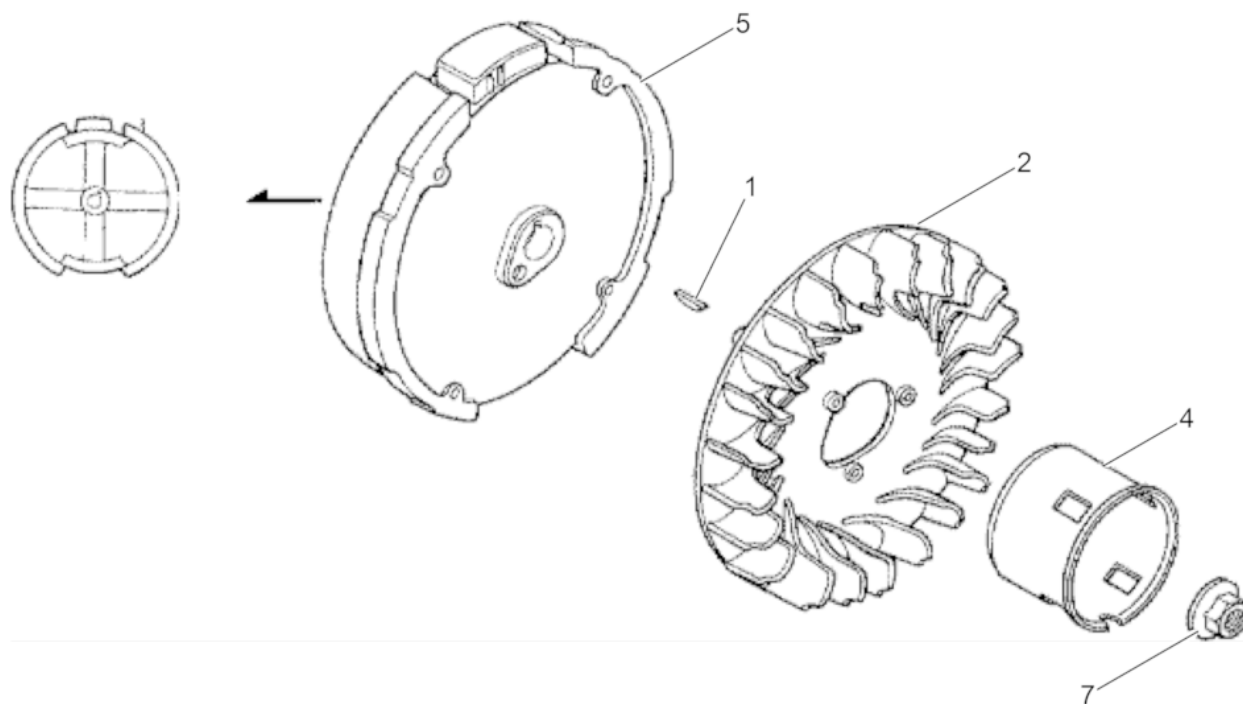

Ref. Pos.	Part No. Artikel Nr.	Qty. St.	Description Beschreibung	Descripción Description	Measurem./Abm.	Norm
					Torque/Drehm.	Sealant Schmierstoff
1	0068967	1	Woodruff key Keil	Chaveta Woodruff Clavette Woodruff	25 x 18	
2	0070976	1	Fan Lüfterrad	Ventilador Ventilateur		
4	0160750	1	Starter Pulley Starterscheibe	Arandela Del Starter Rondelle du Lanceur		
5	0213410	1	Flywheel Schwungrad	Volante Volant		
7	0162686	1	Nut Mutter	Tuerca Écrou	M14	

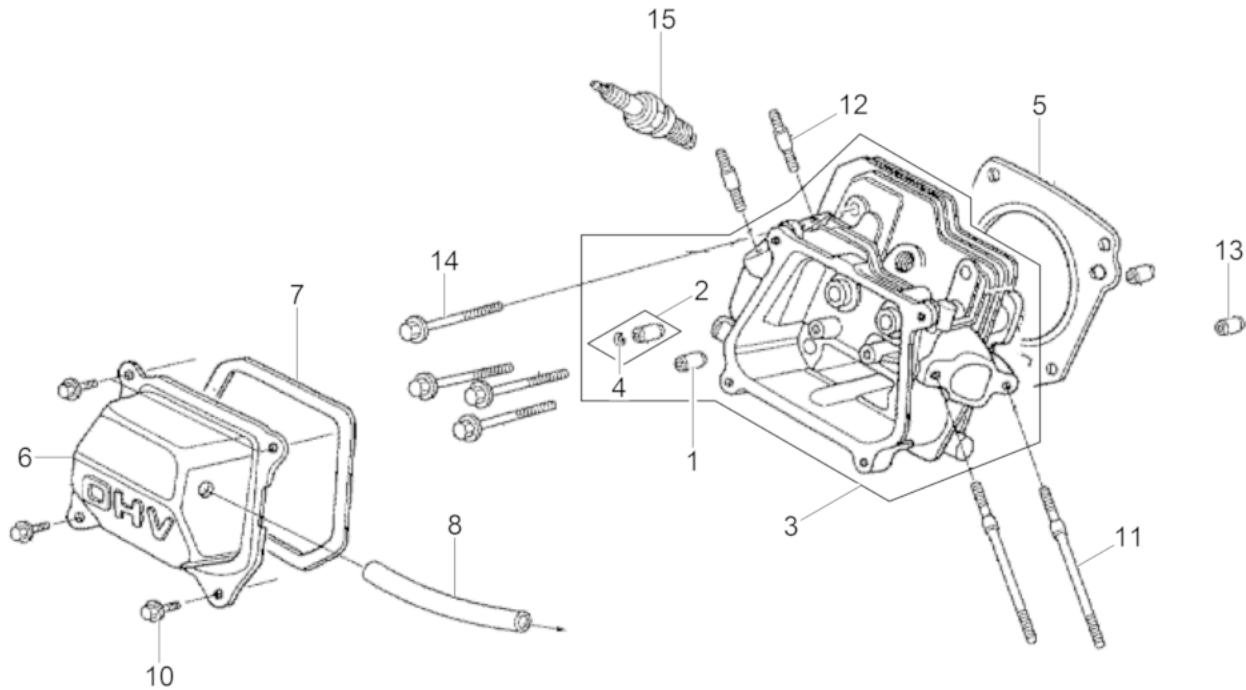

Ref. Pos.	Part No. Artikel Nr.	Qty. St.	Description Beschreibung	Descripción Description	Measurement/Abm.	Norm
					Torque/Drehm.	Sealant Schmierstoff
1	0070945	1	Valve guide Ventilführung	Guía de válvula Guide de soupape		
2	0070944	1	Valve guide Ventilführung	Guía de válvula Guide de soupape		
3	0081786	1	Cylinder head Zylinderkopf	Culata Culasse		
4	0081744	1	Retaining ring Sicherungsring	Anillo de retención Bague d'arrêt		
5	0216514	1	Cylinder head gasket Zylinderkopfdichtung	Junta de culata del cilindro Joint de culasse de cylindre		
6	5100005424	1	Cover cpl. Deckel kpl.	Tapa cpl. Couvercle cpl.		
7	0070942	1	Gasket Dichtung	Junta Joint		
8	0081761	1	Breather tube Entlüftungsrohr	Tubo respiradero Tube reniflard		
10	0053990	4	Screw Schraube	Tornillo Vis	M6 x 12 10Nm/7ft.lbs	
11	5000406696	2	Stud Gewindebolzen	Perno prisionero Goujon		
12	0070948	2	Stud Gewindebolzen	Perno prisionero Boulon	M8 x 32	
13	0070950	2	Dowel pin Passstift	Espiga Cheville		
14	5000217519	4	Flange bolt Flanschbolzen	Perno de reborde Boulon à bride		
15	0150914	1	Spark plug Zündkerze	Bujía Bougie		

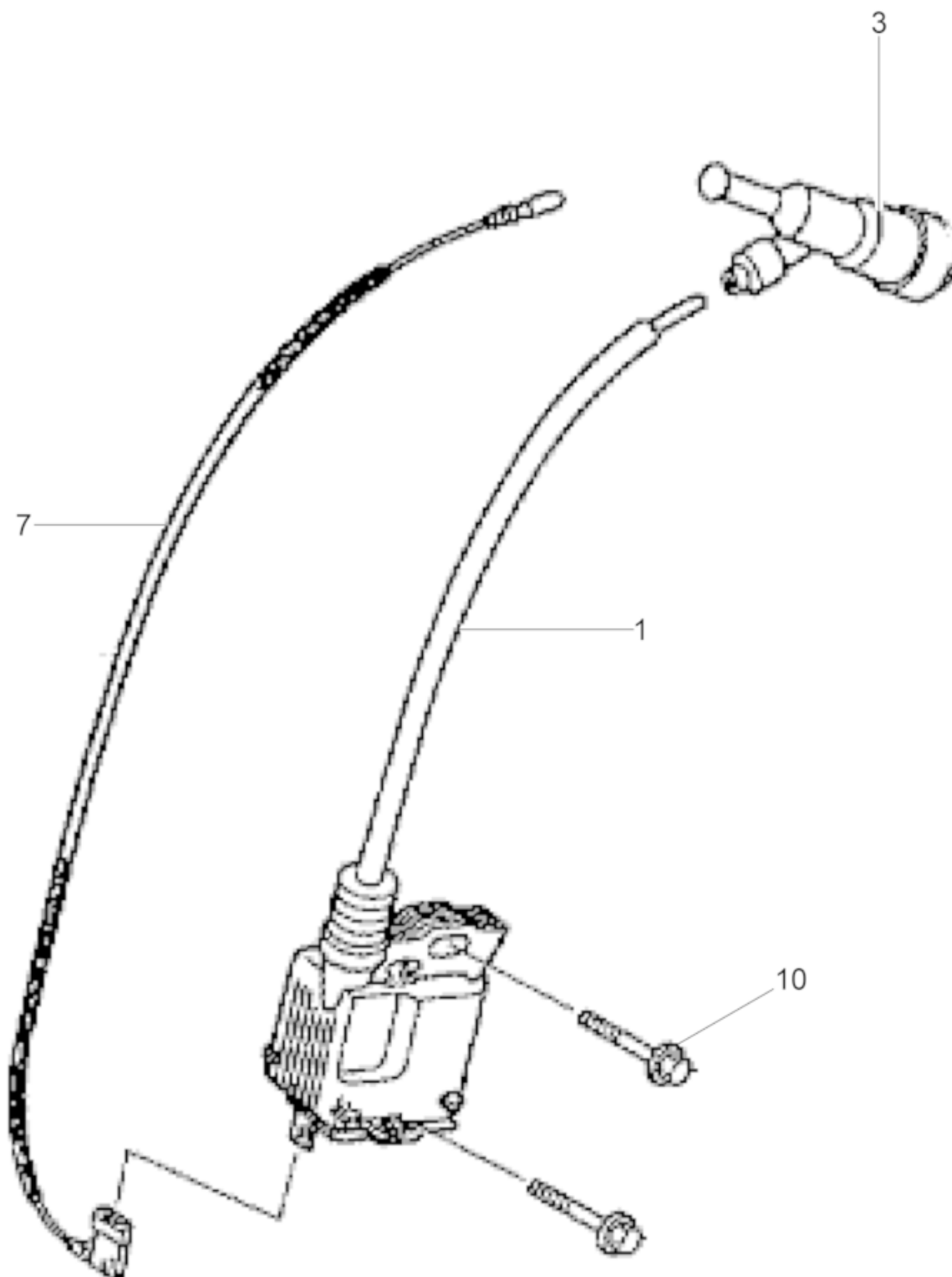

Ref. Pos.	Part No. Artikel Nr.	Qty. St.	Description Beschreibung	Descripción Description	Measurement/Abm.	Norm
					Torque/Drehm.	Sealant Schmierstoff
1	510003455	1	Ignition Coil cpl. Zündspule kpl.	Bobina de Encendido cpl. Bobine d'Allumage cpl.		
3	5100031334	1	Spark plug terminal cap Zündkerzenstecker	Enchufe de bujía Porte bougies		
7	5100031335	1	Cable Kabel	Cable Câble		
10	0081737	2	Screw Schraube	Tornillo Vis	M6 x 25	

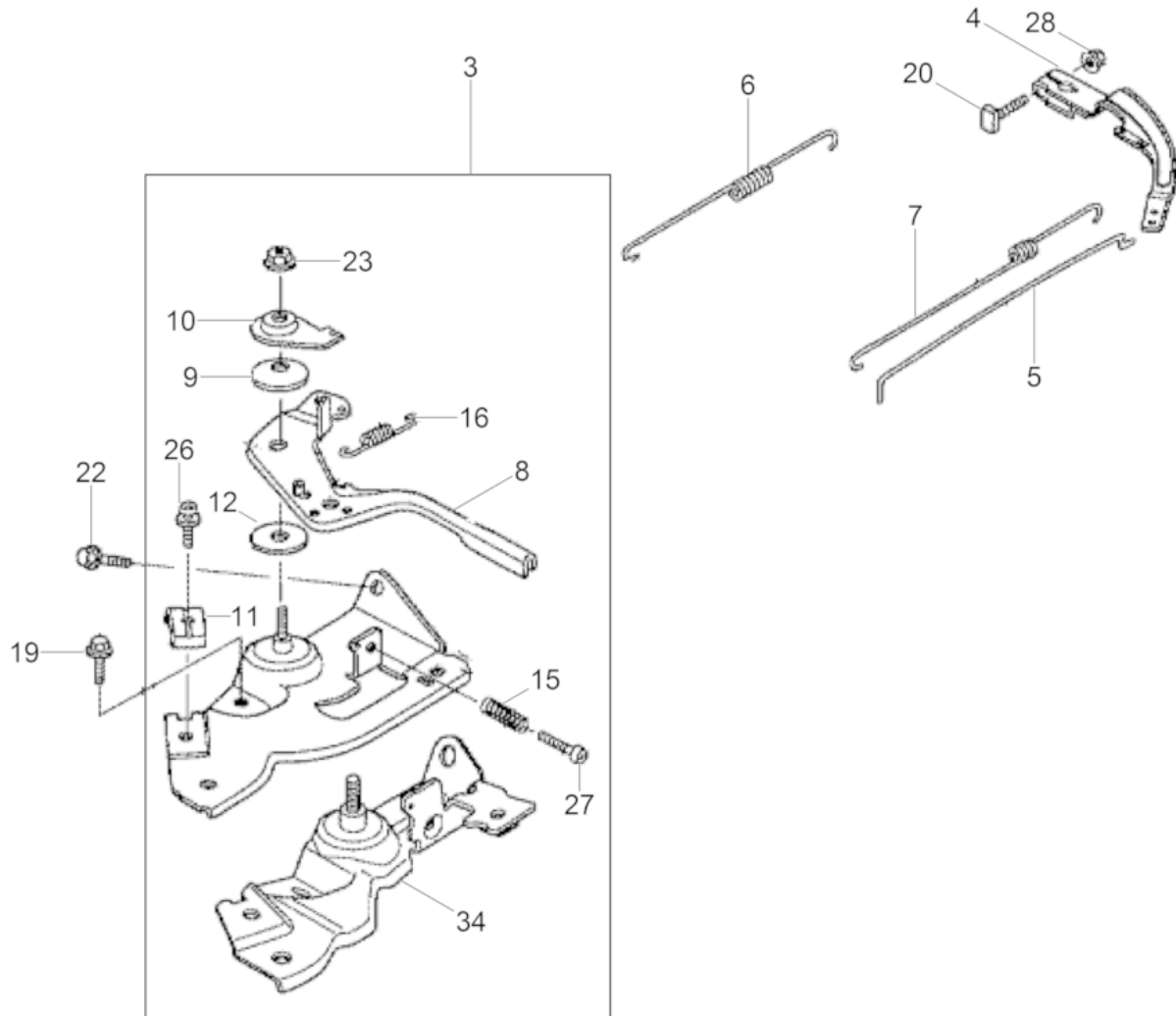

Ref. Pos.	Part No. Artikel Nr.	Qty. St.	Description Beschreibung	Descripción Description	Measurement./Abm.	Norm
					Torque/Drehm.	Sealant Schmierstoff
3	5100029312	1	Governor cpl. Regler kpl.	Regulador cpl. Régulateur cpl.		
4	0081742	1	Governor lever Regulierhebel	Palanca de regulador Levier régulateur		
5	0071068	1	Governor rod Reglerstange	Varillaje de regulación Tige de régulateur		
6	5100031336	1	Governor spring Reglerfeder	Resorte del regulador Ressort régulateur		
7	0081743	1	Spring Feder	Resorte Ressort		
8	5100031337	1	Governor lever Reglerhebel	Palanca Reguladora Levier Régulateur		
9	0071058	1	Spring Feder	Resorte Ressort		
10	0071057	1	Washer Scheibe	Arandela Rondelle		
11	0071062	1	Cable holder Klemme	Soporte cable Attache		
12	0071064	1	Spacer Distanzstück	Espaciador Pièce d'écartement		
15	0054088	1	Adjusting spring Feder	Resorte de ajuste Ressort d'ajustage		
16	0071667	1	Spring Feder	Resorte Ressort		
19	0053990	1	Screw Schraube	Tornillo Vis	M6 x 12 10Nm/7ft.lbs	
20	5100000451	1	Screw Schraube	Tornillo Vis		
22	0071055	1	Screw Schraube	Tornillo Vis	M6 x 20 10Nm/7ft.lbs	
23	0072782	1	Locknut Sicherungsmutter	Contratuerca Contre-écrou	M6	
26	0110112	1	Screw Schraube	Tornillo Vis	5 x 16	
27	0081990	1	Screw Schraube	Tornillo Vis	M5 x 25	
28	0071056	1	Nut Mutter	Tuerca Ecrou	M6	
34	5100029313	1	Bracket Halterung	Soporte Équerre		

Cylinder housing
Zylindergehäuse
Carcasa de cilindro
Carter cylindre

VP1135Aw

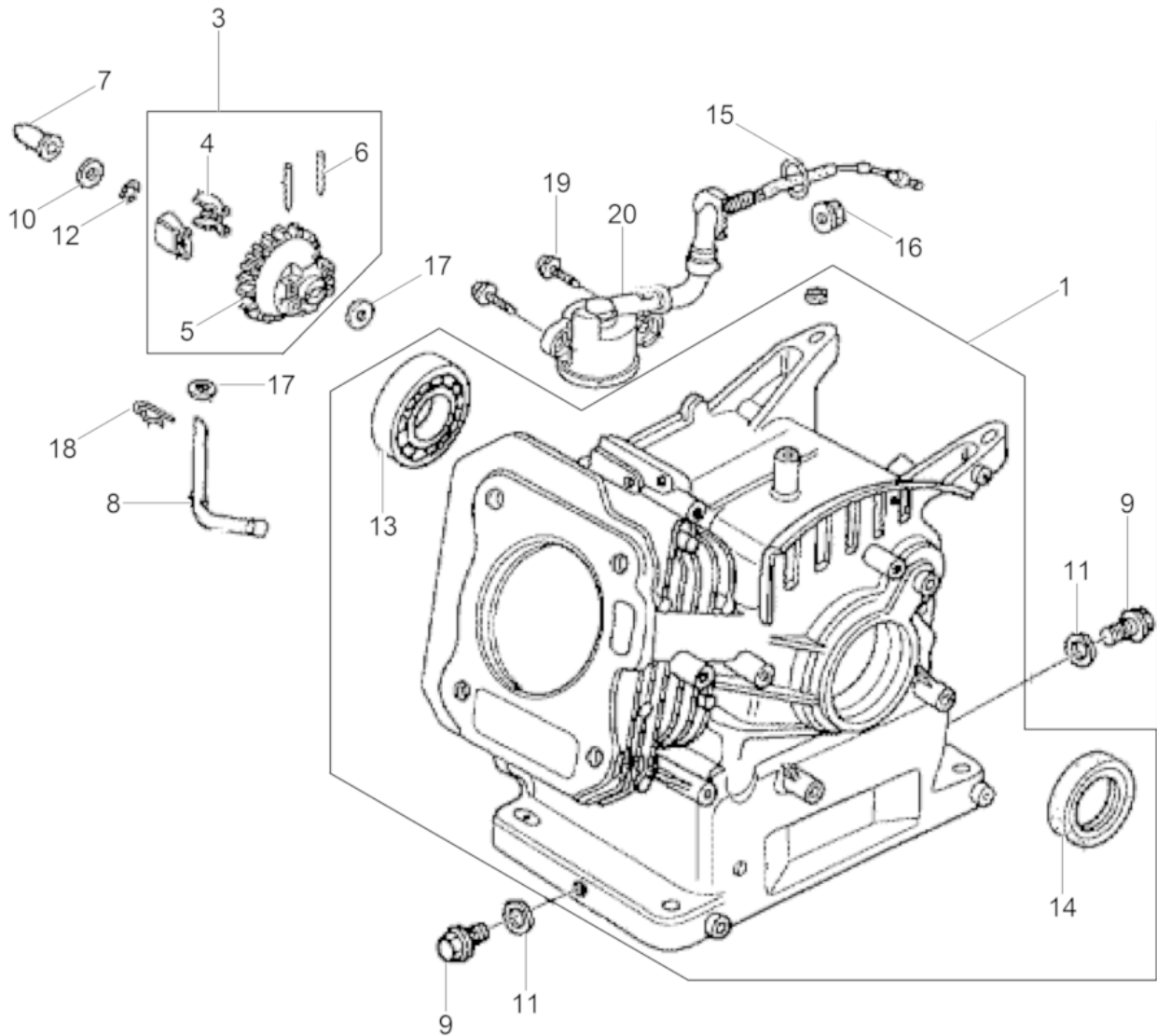

Ref. Pos.	Part No. Artikel Nr.	Qty. St.	Description Beschreibung	Descripción Description	Measurem./Abm.	Norm
					Torque/Drehm.	Sealant Schmierstoff
1	0209782	1	Cylinder Zylinder	Cilindro Cylindre		
3	0076934	1	Governor cpl. Regler kpl.	Regulador compl. Régulateur compl.		
4	0151694	2	Weight Gewicht	Peso Poids		
5	0151695	1	Bracket Halter	Soporte Équerre		
6	0156689	2	Pin Stift	Espiga Goupille		
7	0070953	1	Slider Gleitstück	Manguito Douille		
8	0107060	1	Governor Reglerhebel	Regulador Régulateur		
9	0070964	2	Plug (threaded) Verschlußschraube	Tapón roscado Bouchon		
10	0070959	1	Washer Scheibe	Arandela Rondelle		
11	0070963	2	Washer Scheibe	Arandela Rondelle		
12	0081615	1	Retaining ring Sicherungsring	Anillo de retención Bague d'arrêt		
13	0070961	1	Grooved ball bearing Rillenkugellager	Rodamiento de bolas Roulement à billes		
14	0070962	1	Shaft seal Wellendichtring	Sello del eje Bague d'étanchéité		
15	0208616	1	O-Ring O-Ring	Anillo-O Joint torique	14M	
16	0072332	1	Flange nut Flanschmutter	Tuerca de reborde Ecrou de bride	M10	
17	0071639	2	Washer Scheibe	Arandela Rondelle	6M	
18	0054033	1	Pin Stift	Pasador Goupille		
19	5100003498	2	Flange screw Flanschschraube 6X12	Tornillo de brida Vis de bride	6x12	
20	0216513	1	Oil alert switch cpl. Ölwarnschalter	Modulo-interruptor Module-contacteur		

**Crankcase cover
Kurbelgehäuseabdeckung**

VP1135Aw

**Cubierta da la caja de manivel
Couvercle carter de manivelle**

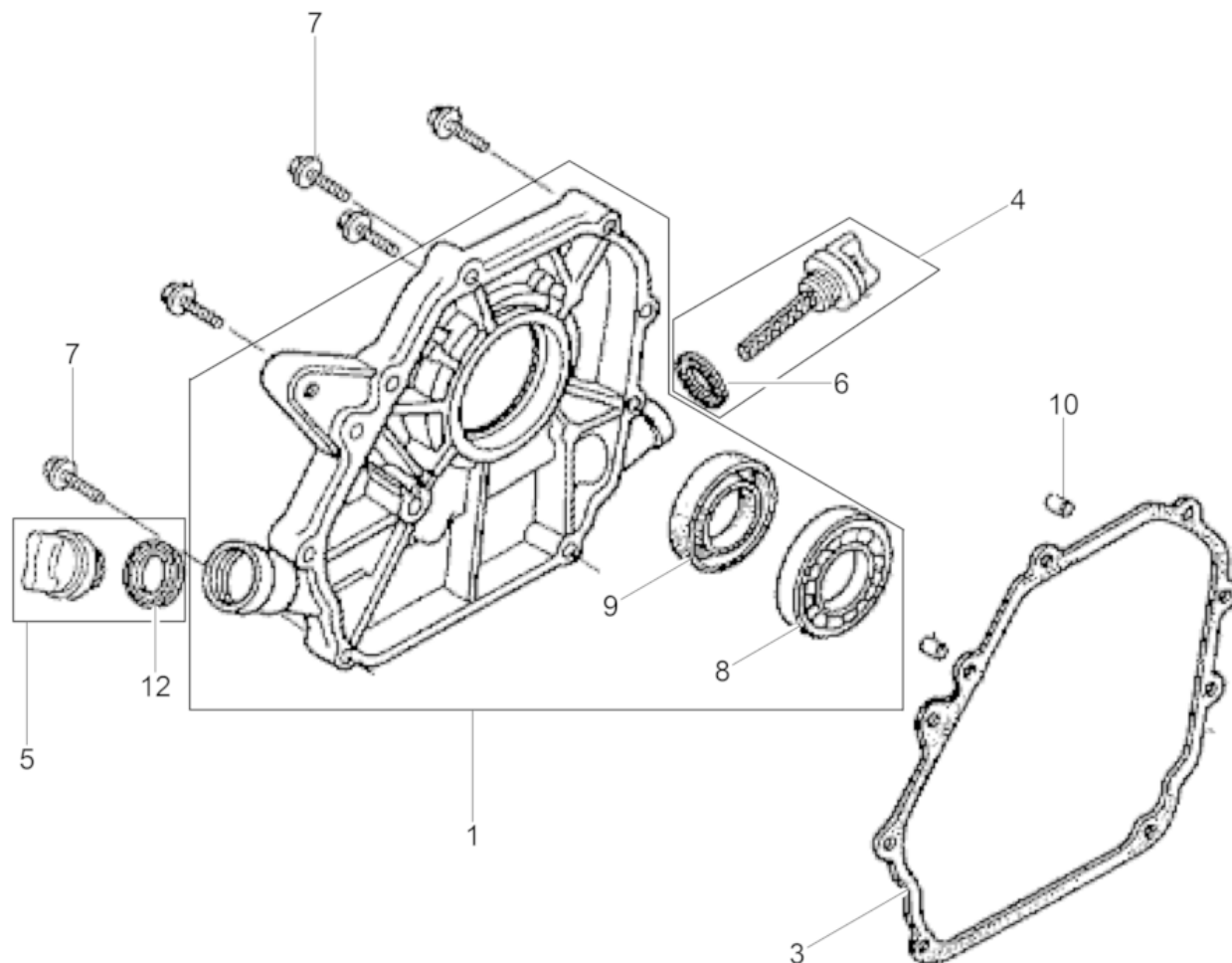

Ref. Pos.	Part No. Artikel Nr.	Qty. St.	Description Beschreibung	Descripción Description	Measurement./Abm.	Norm
					Torque/Drehm.	Sealant Schmierstoff
1	0081740	1	Cover Deckel	Tapa Couvercle		
3	0081783	1	Gasket Dichtung	Junta Joint		
4	0162645	1	Dipstick assembly Peilstab kpl.	Indicador del nivel de aceite compl. Réglette-jauge compl.		
5	0162646	1	Oil filler cap Kappe-Ölfüller	Llenador de aceite Remplisseur d'huile		
6	0162647	1	Gasket Dichtung	Junta de estanqueidad Garniture		
7	0070966	7	Screw Schraube	Tornillo Vis	M6 x 28 10Nm/7ft.lbs	
8	0070961	1	Grooved ball bearing Rillenkugellager	Rodamiento de bolas Roulement à billes		
9	5000209789	1	Oil seal Öldichtung	Empaque de aceite Joint d'huile	22x41x6	
10	0053995	2	Dowel pin Passstift	Espiga Cheville	A8 x 14	
12	0162647	1	Gasket Dichtung	Junta de estanqueidad Garniture		

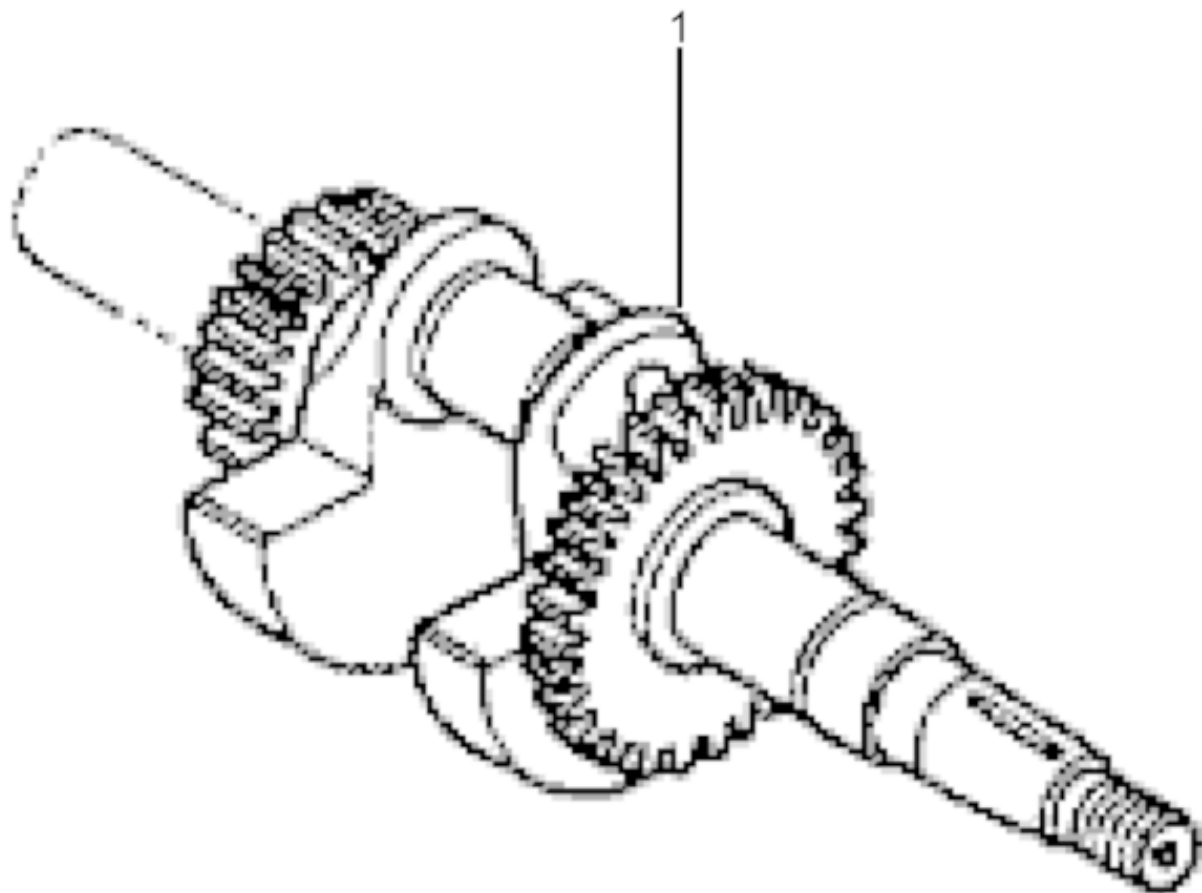

Ref. Pos.	Part No. Artikel Nr.	Qty. St.	Description Beschreibung	Descripción Description	Measurem./Abm.	Norm
					Torque/Drehm.	Sealant Schmierstoff
2	0216512	1	Crankshaft Kurbelwelle	Cigüeñal Vilebrequin		

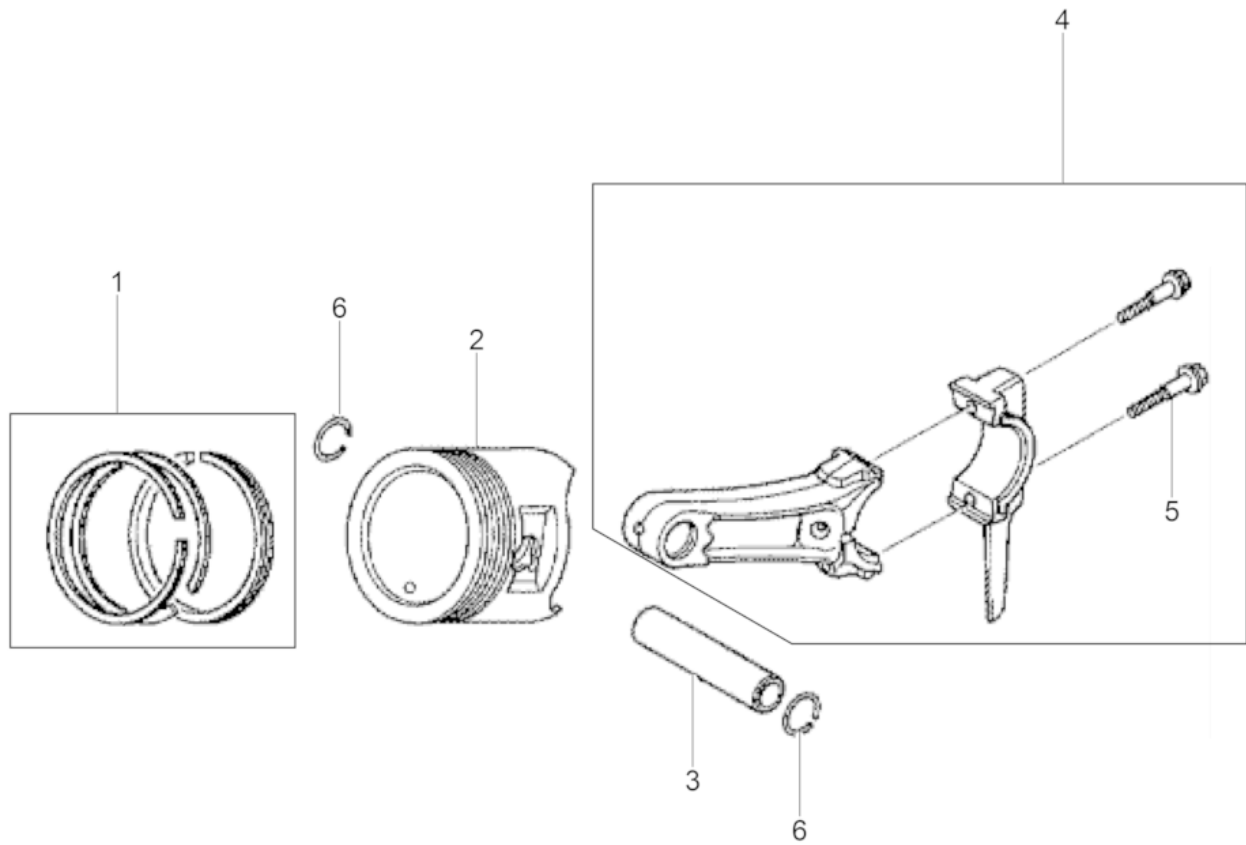

Ref. Pos.	Part No. Artikel Nr.	Qty. St.	Description Beschreibung	Descripción Description	Measurement./Abm.	Norm
					Torque/Drehm.	Sealant Schmierstoff
1	0213401	1	Piston w/Ring Set Satz-Kolben mit Kolbenringen	Juego-pistón con aros Jeu-piston avec segments		
1	0213402	1	Piston w/Ring Set Satz-Kolben mit Kolbenringen	Juego-pistón con aros Jeu-piston avec segments	0.25	
1	0213404	1	Piston w/Ring Set Satz-Kolben mit Kolbenringen	Juego-pistón con aros Jeu-piston avec segments	0.75	
1	0213403	1	Piston w/Ring Set Satz-Kolben mit Kolbenringen	Juego-pistón con aros Jeu-piston avec segments	0.5	
2	0213408	1	Piston Kolben	Pistón Piston	0.5	
2	0213406	1	Piston Kolben	Pistón Piston	0.25	
2	0213405	1	Piston Kolben	Pistón Piston		
2	0213407	1	Piston Kolben	Pistón Piston	0.5	
3	0071008	1	Piston pin Kolbenbolzen	Pasador de pistón Axe de piston		
4	0209799	1	Connecting rod Pleuel	Biela Bielle		
5	0071007	2	Screw Schraube	Tornillo Vis	M7 x 35	
6	0081751	2	Retaining ring Sicherungsring	Anillo de retención Bague d'arrêt		

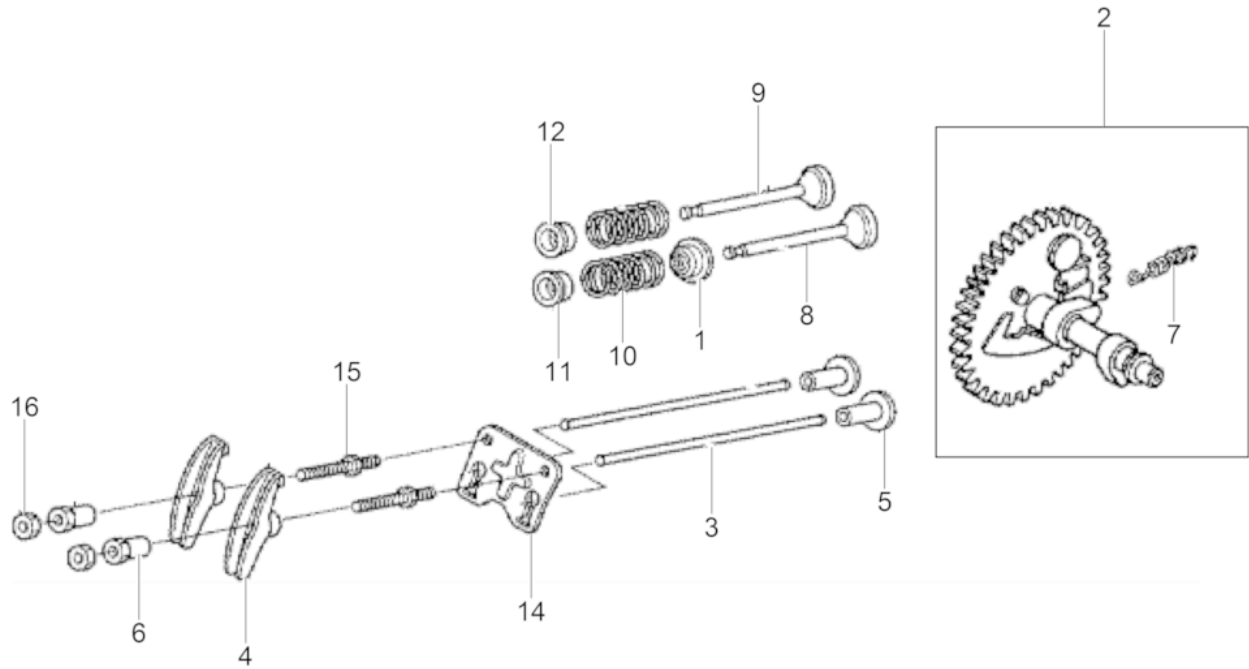

Ref. Pos.	Part No. Artikel Nr.	Qty. St.	Description Beschreibung	Descripción Description	Measurement./Abm.	Norm
					Torque/Drehm.	Sealant Schmierstoff
1	5100005349	1	Gasket Dichtung	Junta Joint		
2	0072902	1	Camshaft Nockenwelle	Arbol de levas Arbre à cames		
3	0070989	2	Push rod (valve lifter) Stoßstange	Levantaválvula Poussoir de soupape		
4	0070986	2	Rocker arm Kipphebel	Balancín Culbuteur		
5	0070990	2	Valve tappet Ventilstößel	Levantaválvula Poussoir		
6	5100031338	2	Pin Zapfen	Pivote Pivot		
7	0151028	1	Spring Feder	Resorte Ressort		
8	5000406703	1	Intake valve Einlaßventil	Válvula de admisión Soupape d'admission		
9	5100029317	1	Exhaust valve Auslassventil	Válvula de escape Soupape d'échappement		
10	0081760	2	Spring Feder	Resorte Ressort		
11	5100031339	1	Holder Halter	Soporte Attache		
12	5100031339	1	Holder Halter	Soporte Attache		
14	0070988	1	Plate Platte	Placa Plaque		
15	0072778	2	Stud Gewindebolzen	Perno prisionero Boulon	8	
16	0070984	2	Locknut Sechskantmutter	Contratuercas Contre-écrou	1/4-28in	

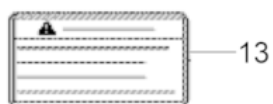
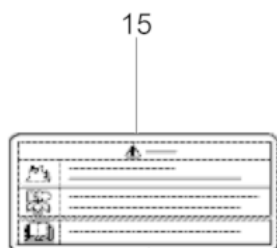
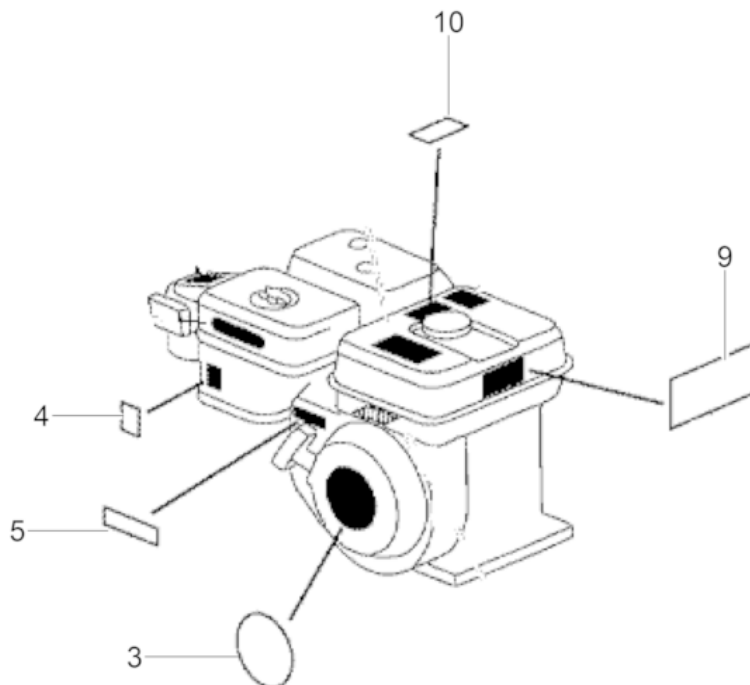

Ref. Pos.	Part No. Artikel Nr.	Qty. St.	Description Beschreibung	Descripción Description	Measurement./Abm.	Norm
					Torque/Drehm.	Sealant Schmierstoff
3	5100029316	1	Label Aufkleber	Calcomanía Autocollant		
4	5100005336	1	Label Aufkleber	Calcomanía Autocollant		
5	0208623	1	Labels Aufkleber	Calcomanias Autocollants		
9	5100000437	1	Warning Label Warnhinweiß	Etiqueta Amonestadora Étiquette D'avertissement		
10	5100005337	1	Label Aufkleber	Calcomanía Autocollant		
11	5100000438	1	Warning Label Warnhinweiß	Etiqueta Amonestadora Étiquette D'avertissement		
12	5100000439	1	Warning Label Warnhinweiß	Etiqueta Amonestadora Étiquette D'avertissement		
13	5100005339	1	Label Aufkleber	Calcomanía Autocollant		
14	5100005340	1	Label Aufkleber	Calcomanía Autocollant		
15	5100005341	1	Label Aufkleber	Calcomanía Autocollant		



**WACKER
NEUSON**

**Accessoires
Zubehör
Accesorios
Accessories**

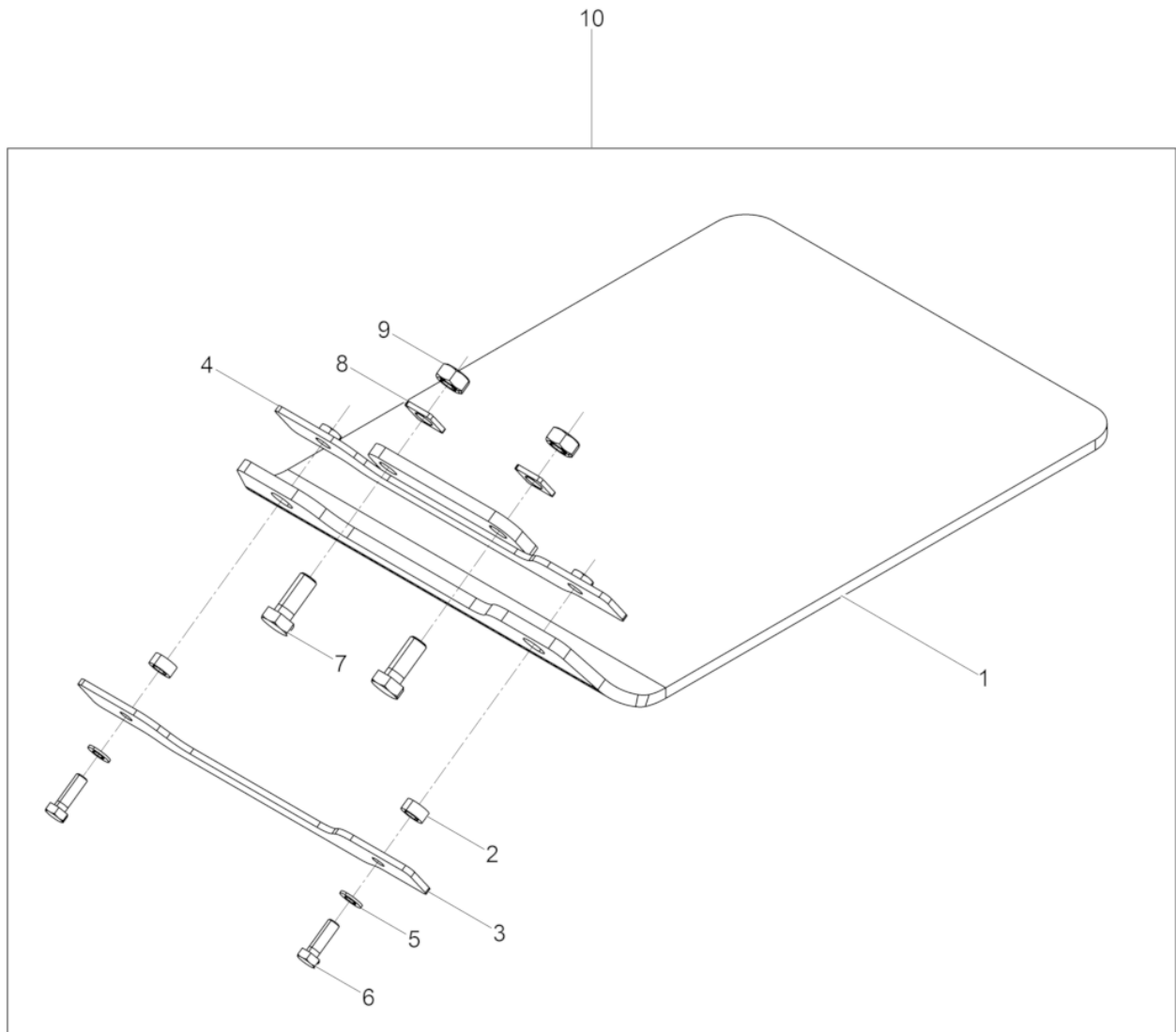

Ref. Pos.	Part No. Artikel Nr.	Qty. St.	Description Beschreibung	Descripción Description	Measurement./Abm.	Norm
					Torque/Drehm.	Sealant Schmierstoff
1	5100018425	1	urethane plate Kunststoffplatte	Juego de lamina de uretano Dispositif de glissement		
2	5100017122	2	Bush Buchse	Buje Boîte		
3	5100018426	1	Plate Blech	Chapa Tôle		
4	5100018427	1	Bracket Halterung	Soporte Équerre		
5	0010622	2	Flat washer Scheibe	Arandela Rondelle		
6	0011457	2	Hexagonal head cap screw Sechskantschraube	Tornillo hexagonal Vis à tête hexagonale	M8 x 25 31Nm/23ft.lbs	DIN933
7	5000106674	2	Hexagonal head cap screw Sechskantschraube	Tornillo hexagonal Vis à tête hexagonale	M12 x 30 86Nm/63ft.lbs	DIN933
8	5100018430	2	Disc Scheibe	Disco Disque	22 x 22	
9	0010884	2	Hexagon nut Sechskantmutter	Tuerca hexagonal Écrou hexagonal	M12	DIN934
10	5100018424	1	Urethane Pad Kit Gleitvorrichtung	Placa de Deslizamiento Jeu de Tapis en Polyuréthane		

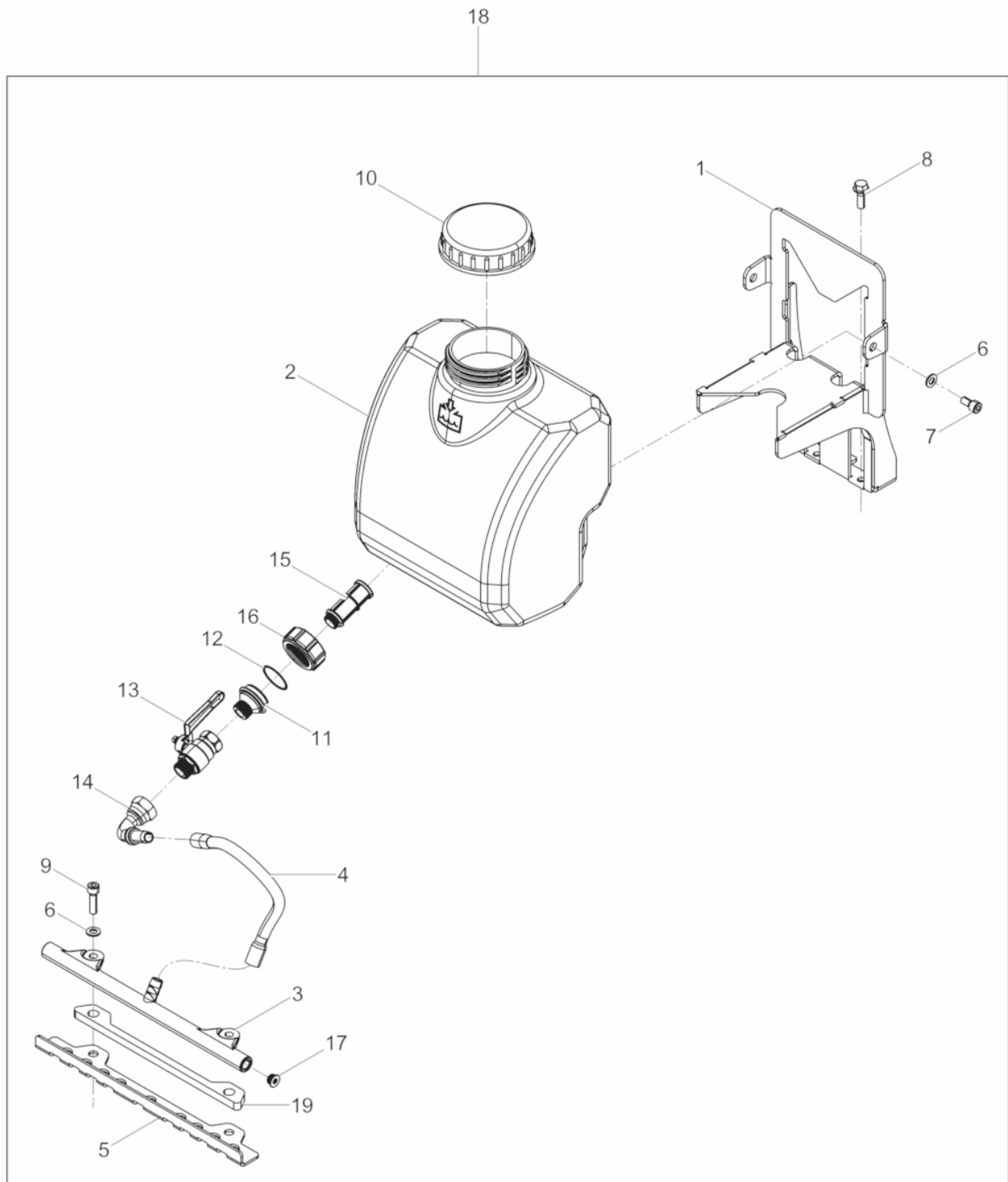

Ref. Pos.	Part No. Artikel Nr.	Qty. St.	Description Beschreibung	Descripción Description	Measurem./Abm.	Norm
					Torque/Drehm.	Sealant Schmierstoff
1	5100028973	1	Bracket Wassertankhalterung	Soporte Équerre		
2	5100028898	1	Watertank Wassertank	Tanque de agua Reservoir à eau		
3	5100030374	1	Spinkler system Berieselung	Systema de riego Installation d'Arrosage		
4	5100036378	1	Water Hose Wasserschlauch	Manguera de agua Tuyau d'eau		
5	5100028917	1	Guard plate Schutzblech	Chapa protectora Tôle de protection		
6	0010622	4	Flat washer Scheibe	Arandela Rondelle		
7	0011544	2	Cheese head screw Zylinderschraube	Tornillo cilíndrico Vis à tête cylindrique	M8 x 16 25Nm/18ft.lbs	ISO4762
8	5100035900	4	Hexagonal head cap screw Sechskantschraube	Tornillo hexagonal Vis à tête hexagonale		
9	0011541	2	Cheese head screw Zylinderschraube	Tornillo cilíndrico Vis à tête cylindrique		
10	0068351	1	Screwed cover Schraubdeckel	Tapa roscable Couvercle fileté		
11	5100028921	1	Flange Flansch	Brida Bride		
12	5100028922	1	O-ring O-Ring	Anillo-O Bague-O		
13	5100028889	1	Ball valve Kugelhahn	Llave esférica Robinet à boisseau spherique		
14	5100028897	1	Connector Pressnippel	Conector Connexion		
15	5100028890	1	water filter Wasserfilter	filtro de agua Filtre		
16	5100028920	1	Cap screw Überwurfmutter	Tuerca de racor Écrou d'accouplement		
17	5100029615	2	Plug Einschraubstopfen	Tapón Bouchon		
18	5100029069	1	Spinkler system cpl. Berieselung kpl.	Systema de Riego cpl. Installation d'arrosage cpl.		
19	5100028918	1	Plate Blech	Chapa Tôle		



**WACKER
NEUSON**