



**WACKER
NEUSON**

0610143	105
09.2018	

**Reversible Plates
Reversierbare Platten
Planchas Reversibles
Plaques réversible**

DPU 130Le

**Parts Book
Ersatzteile
Lista de Repuestos
Liste de Pièces de Rechange**

www.wackerneuson.com

A nameplate listing the Model Number, Item Number, Revision, and Serial Number is attached to each unit. Please record the information found on this plate so it will be available should the nameplate become lost or damaged. When ordering parts or requesting service information, you will always be asked to specify the model, item number, revision number, and serial number of the unit.

Ein Typenschild mit Typ, Artikelnummer, Version und Maschinen-Nummer ist an jedem Gerät angebracht. Die Daten von diesem Schild bitte notieren, damit sie auch bei Verlust oder Beschädigung des Schildes noch vorhanden sind. Der Typ, die Artikel-Nummer, die Versions- Nummer und die Maschinen-Nummer sind bei der Ersatzteilbestellung oder Nachfragen bezüglich Service-Informationen stets erforderlich.

Una placa de identificación con el modelo, número de referencia, nivel de revisión y número de serie ha sido añadida en cada máquina. Favor de anotar los datos en la placa en caso de que la placa de identificación sea destruida o perdida. En todos los pedidos para repuestos necesita siempre el modelo, el número de referencia, el nivel de revisión y el número de serie de la máquina en cuestión.

Une plaque signalétique mentionnant le modèle, le numéro de référence, le niveau de révision et le numéro de série est fixée sur chaque machine. Veuillez noter les informations relevées sur cette plaque de façon à ce qu'elles soient toujours disponibles si la plaque signalétique venait à être perdue ou endommagée. Lorsque vous commandez des pièces détachées ou vous sollicitez des informations après-vente, on vous demandera toujours de préciser le modèle, le numéro de référence, le niveau de révision et le numéro de série de la machine.

***My machine's numbers are / Die Nummern meines Gerätes sind /
 Los números de mi máquina son / Les numéros de ma machine son :***



Part Numbers appearing in boldface type are recommended spare parts. This means that these parts are subject to wear under normal operating conditions and may require periodic service or replacement. It is recommended that these items be stocked to meet the expected service requirements of this model. Actual stocking quantities of these and other parts used in more extensive repairs will depend on the service practices of each customer.

Bei den in den Ersatzteillisten fettgedruckten Nummern handelt es sich um empfohlene Ersatzteile. Dies bedeutet, daß diese Teile bei normalen Anwendungsbedingungen natürlicher Abnutzung ausgesetzt sind und gelegentlich ersetzt oder überarbeitet werden müssen. Es wird geraten, diese Teile auf Lager bereit zu haben, um für Service-Arbeiten an diesem Gerät vorbereitet zu sein. Lagerbestände für diese und andere Teile, welche für ausgiebigere Reparaturarbeiten benötigt werden, können je nach Service-Gewohnheiten der einzelnen Kunden variieren.

Los números de partes en negritas en las Listas Ilustradas de Partes son los repuestos recomendados, esto quiere decir que estas partes se desgastarán bajo circunstancias de funcionamiento normales y pueden requerir servicio periódico o su reemplazo. Se recomienda que el cliente mantenga un abastecimiento adecuado de estas partes para poder satisfacer la demanda requerida por el servicio a la máquina. La cantidad de repuestos que el cliente necesitará para reparaciones dependerá de la póliza de servicio de cada cliente.

Les numéros de pièces imprimés en caractères gras dans les Listes des Pièces Détachées de ce manuel sont les pièces détachées recommandées par la Wacker. Cela veut dire que ces pièces sont sujettes à usure dans des conditions de travail normales et peuvent nécessiter de l'entretien ou leur remplacement. Nous recommandons que vous disposez d'un stock de ces pièces pour pouvoir satisfaire la demande d'entretien de cette machine. Le client doit décider lui-même de la quantité exacte de pièces de rechange qu'il disposera dans ses stocks.

Upper mass Obermasse Masa superior Massa superieure	8
Upper mass - rear end Obermasse-Heckbereich Masa superior - atrás Massa superieure - arrière	12
Bonnet rear Haube hinten Cubierta atrás Capot arrière	16
Bonnet front Haube vorne Cubierta delantero Capot avant	20
Hydraulic Tank cpl. Hydrauliktank kpl. Tanque Hidráulico cpl. Réservoir Hydraulique cpl.	24
Return filter Rücklauffilter Filtro de retorno Filtre de retour	26
Hydraulic hose System Upper mass Hydraulikverschlauchung Obermasse Manguera hidráulica Sistema Masa superior Tuyau hydraulique Système	28
Fuel Tank Kraftstofftank Depósito de Combustible Réservoir à Essence	30
Electric Elektrik Eléctrico Électrique	32
Electric components drawer Elektrobox Caja eléctrica Coffret électrique	34
Battery Batterie Batería Batterie	36
Transmitter Sender kpl. Transmisor Transmetteur	38
Centre cross bar Mitteltraverse Travesaño central Entretoise	40
Diesel Engine cpl. Dieselmotor kpl. Motor Diesel cpl. Moteur Diesel cpl.	42

Indice**Table des matières**

Baseplate Untermasse Masa inferior Masse inferieure	50
Block-Hydraulic Hydraulikblock Bloque Hidráulico Bloc Hydraulique	52
Exciter cpl. left Erreger kpl. links Excitador cpl. izquierda Excitateur cpl. gauche	56
Exciter cpl. right Erreger kpl. rechts Excitador cpl. derecho Excitateur cpl. droite	60
Adjustment cylinder Verstellzylinder Cilindro del ajuste Cylindre d'ajustement	64
Labels Aufkleber Calcomanias Autocollants	66
Labels US Aufkleber US Calcomanias US Autocollants US	68
Engine Motor Motor Moteur	71
Crank gear Kurbeltrieb Mecanismo de manivella Arbre manivelle	72
Crankcase cpl. Kurbelgehäuse kpl. Cárter cpl. Carter cpl.	74
Cylinder head Zylinderkopf Culata Culasse	78
Injection System Einspritzanlage Sistema de Inyección Équipement d' Injection	84
Camshaft Nockenwelle Arbol de levas Arbre à cames	88
timing belt Steuerriemen Polea tensora de correa Tendeur de courroie	90

Oil pump Ölpumpe Bomba de aceite Pompe à huile	92
Oil pan Ölwanne Carter de Aceite Cuvette Carter à Huile	94
Speed control module Drehzahlregler Controlador de velocidad Régulateur de vitesse	96
Fuel pump Kraftstoffpumpe Bomba de combustible Pompe à combustible	100
Fan Lüfter Ventilador Ventilateur	102
Thermostat Thermostat Termóstato Thermostat	106
Water pump Wasserpumpe Bomba de agua Pompe à eau	108
Inlet bend Ansaugkrümmer Codo de aspiración Coude d'aspiration	110
exhaust systems Abgasanlage dispositivos de escape dispositifs d'échappement	112
Generator - Starter Generator-Starter Generador - Arrancador Générateur - Démarreur	114
Hydraulic coupling Hydraulikanschluss Acoplamiento hidráulico Couplage hydraulique	116
Service Service Servicio Service	119
Block-Hydraulic kit Hydraulikblock Satz Bloque Hidráulico Juego Bloc Hydraulique Jeu	120

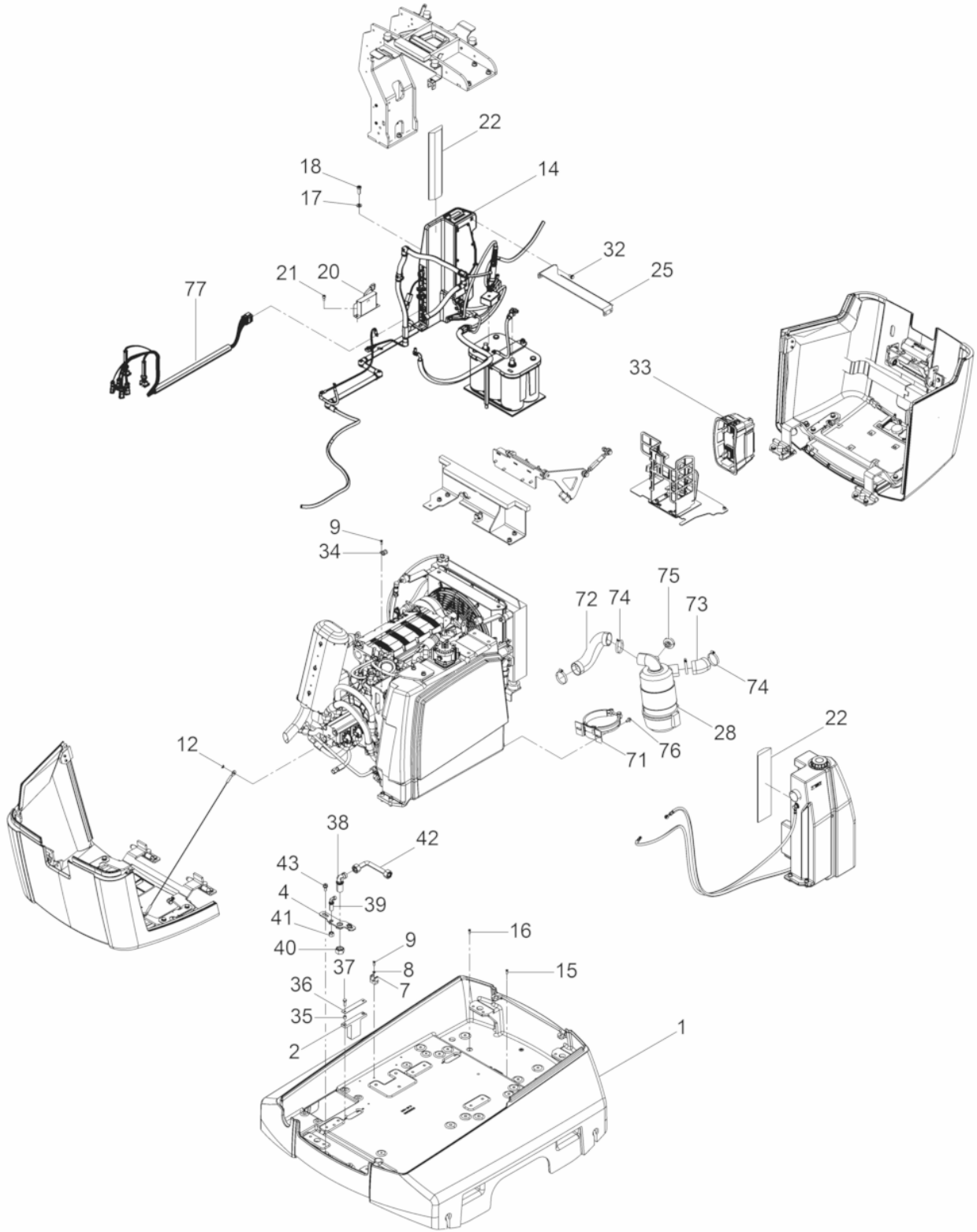

Ref. Pos.	Part No. Artikel Nr.	Qty. St.	Description Beschreibung	Descripción Description	Measurement/Abm.	Norm
					Torque/Drehm.	Sealant Schmierstoff
1	0205360	1	Upper Mass Obermasse	Masa Superior Masse Superieure		
2	0205362	2	Limit stop Anschlag	Dispositivo limitador Dispositif limiteur		
4	0206538	1	Plate Blech	Chapa Tôle		
7	0210107	5	Clamp Schlauchklemme	Abrazadera Collier de serrage		
8	0010624	5	Flat washer Scheibe	Arandela Rondelle		
9	0211755	8	Screw Schraube	Tornillo Vis		
12	0033356	1	Hexagon nut Sechskantmutter	Tuerca hexagonal Écrou hexagonal		
14	5100006140	1	Electric cpl. Elektrik kpl.	Eléctrico cpl. Électrique cpl.		
15	0012381	1	Cheese head screw Zylinderschraube	Tornillo cilíndrico Vis à tête cylindrique	M10 x 16 49Nm/36ft.lbs	ISO4762
16	0011554	1	Cheese head screw Zylinderschraube	Tornillo cilíndrico Vis à tête cylindrique	10Nm/7ft.lbs	
17	0010621	3	Washer Scheibe	Arandela Rondelle		
18	0011534	3	Cheese head screw Zylinderschraube	Tornillo cilíndrico Vis à tête cylindrique	M10 x 30 49Nm/36ft.lbs	ISO4762
20	0209156	1	overload sensor Maschinenschutz	sobrecarga Sensor surcharge capteur		
21	0011544	2	Cheese head screw Zylinderschraube	Tornillo cilíndrico Vis à tête cylindrique	M8 x 16 25Nm/18ft.lbs	ISO4762
22	0206583	2	Seal Abdichtung	Junta Joint		
25	0206578	1	Connection Verbindung	Conexión Connexion		
28	0206421	1	Air Cleaner Luftfilter	Filtro del Aire Filtre à Air		
28	0171456	2	Clamp Klemme	Abrazaderaro de aire Pince		
28	0160171	1	Filter insert Filtereinsatz	Cartucho filtrante Element filtrant		
32	0211795	4	corrugated-head screw Sicherungsschraube	Tornillo Vis		
33	0206484	1	Transmitter Sender	Transmisor Transmetteur		
34	0212145	1	Clamp Rohrschelle	Abrazadera Agrafe	RSGU 1.13/15	
35	0128746	4	Bushing Buchse	Buje Douille		
36	0207331	2	Reinforcement Verstärkung	Refuerzo Renforcement		
37	0011457	4	Hexagonal head cap screw Sechskantschraube	Tornillo hexagonal Vis à tête hexagonale	M8 x 25 25Nm/18ft.lbs	DIN933

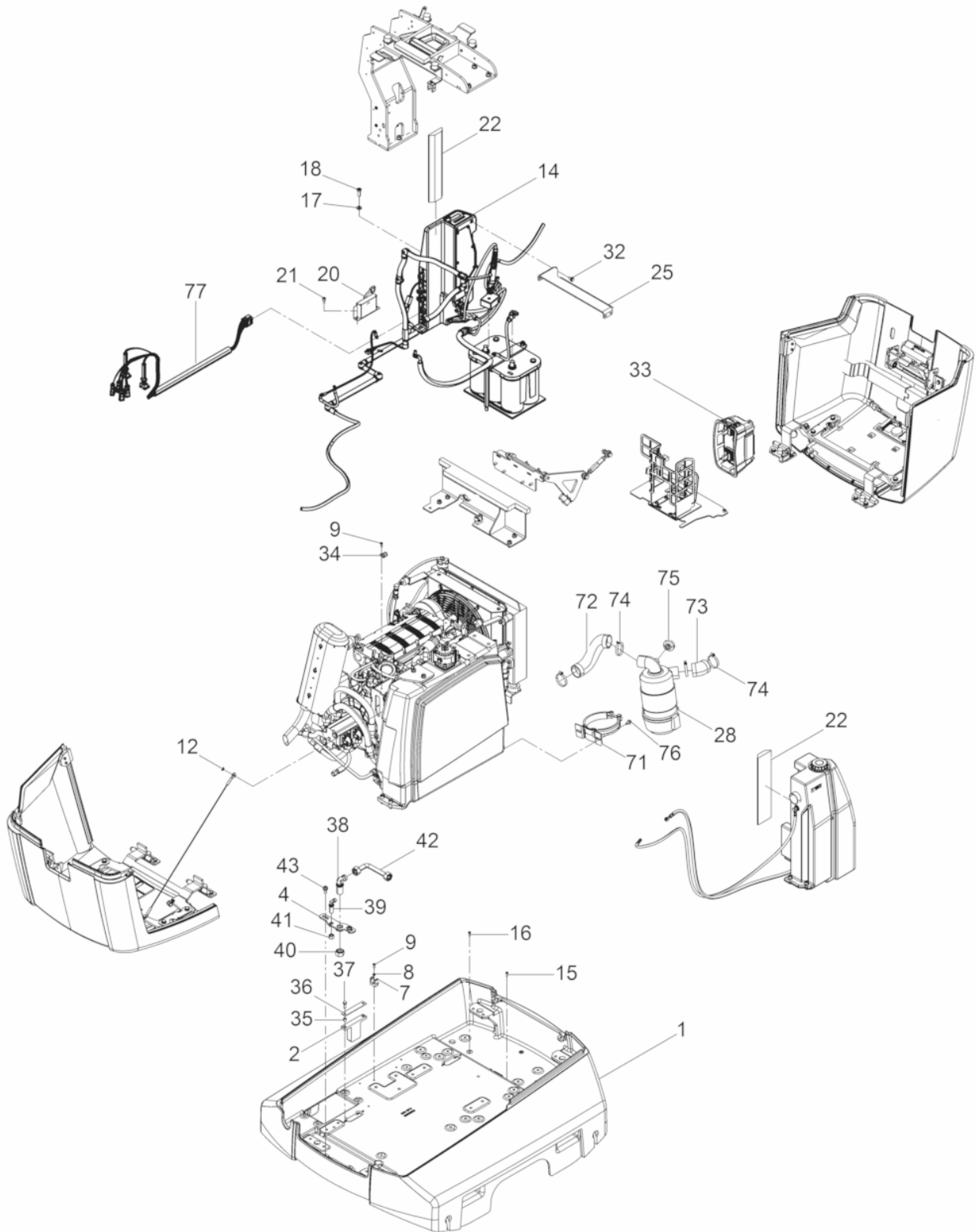

Ref. Pos.	Part No. Artikel Nr.	Qty. St.	Description Beschreibung	Descripción Description	Measurem./Abm.	Norm
					Torque/Drehm.	Sealant Schmierstoff
38	0205239	1	Screw connection Winkel-Schottverschraubung	Atornilladura Raccord vis	WSV18L	
39	0205238	1	Screw connection Winkel-Schottverschraubung	Atornilladura Raccord vis		
40	0211774	1	Nose cap Verschlusskappe	Tapa de cierre Chape de fermeture	M 26x 1,5	
41	0211773	1	Nose cap Verschlusskappe	Tapa de cierre Chape de fermeture		
42	0206498	1	Tube Rohr	Tubo Tube		
43	0210112	2	corrugated-head screw Sicherungsschraube	Tornillo Vis		
71	0206423	1	Clamp Schelle	Abrazadera Attache	143 - 151	
72	0206424	1	Suction hose Ansaugschlauch	Manguera de succión Tuyau de succion		
73	0206420	1	Suction hose Ansaugschlauch	Manguera de succión Tuyau de succion		
74	0014996	4	Clamp Schneckengewindeschelle	Abrazadera Agrafe		
75	0206422	1	Switch Wartungsschalter	Interruptor Interrupteur		
76	0211795	2	corrugated-head screw Sicherungsschraube	Tornillo Vis		
77	5100031275	1	Cable harness Valve Kabelbaum Ventil	Disp. del cable de elevación Válvula Faisceau de câbles Soupape		

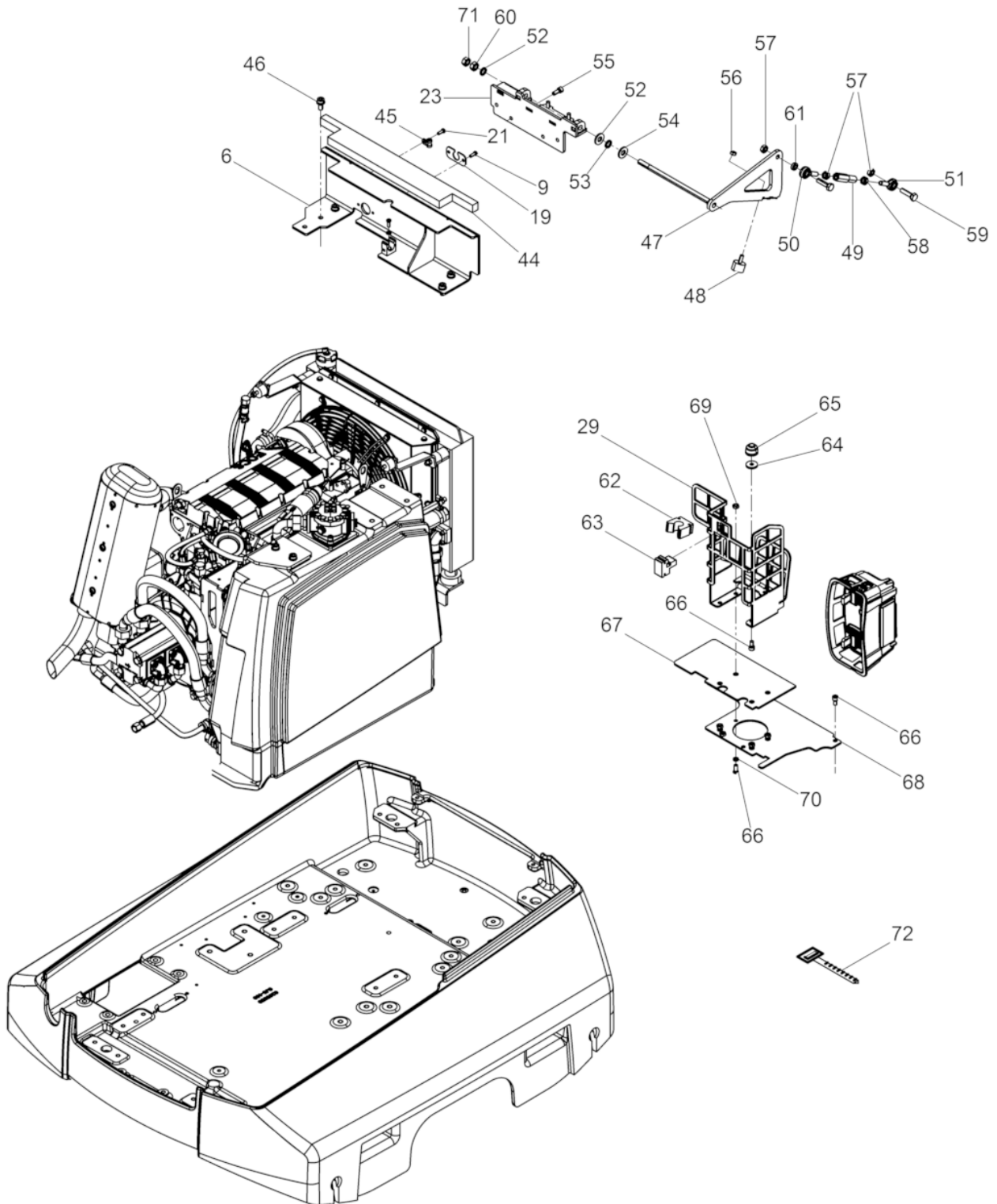

Ref. Pos.	Part No. Artikel Nr.	Qty. St.	Description Beschreibung	Descripción Description	Measurem./Abm.	Norm
					Torque/Drehm.	Sealant Schmierstoff
6	0210143	1	Bulkhead Assembly Trennwand	Conjunto Mamparo Cloison de Séparation		
9	0211755	2	Screw Schraube	Tornillo Vis		
19	0212141	1	Plate Blech	Chapa Tôle		
21	0011544	1	Cheese head screw Zylinderschraube	Tornillo cilíndrico Vis à tête cylindrique	M8 x 16 25Nm/18ft.lbs	ISO4762
23	0211792	1	Angle cpl. Winkel kpl.	Ángulo cpl. Coude cpl.		
25	0206578	1	Connection Verbindung	Conexión Connexion		
29	0207750	1	Bracket Halterung	Soporte Équerre		
44	0206582	1	Seal Abdichtung	Junta Joint		
45	0212143	1	Clamp Rohrschelle	Abrazadera Agrafe	RSGU 1.6/15	
46	0210111	4	corrugated-head screw Sicherheitsschraube	Tornillo Vis		
47	0211754	1	Yoke lever Hebelschwinge	Horquilla Coulisse à levier		
48	0210113	2	Shockmount Anschlagpuffer	Amortiguador Silentbloc	30 x 20 M8 x 18	
49	0210136	1	lock nut Stellmutter	tuerca de ajuste Ecrou		
50	0210134	1	Joint head Gelenkkopf	Cabezal de articulación Tête articulation		
51	0210135	1	Joint head Gelenkkopf	Cabezal de articulación Tête articulation		
52	0010740	2	Washer Scheibe	Arandela Rondelle	13	
53	0210132	1	Supporting Washer Stützscheibe	Arandela de Soporte Disque D'Appui	S 12x 18 x1,2	DIN988
54	0031565	2	Lockwasher Spannscheibe	Arandela elástica Rondelle de ressort	12	DIN6796
55	0011543	1	Socket head screw Zylinderschraube	Tornillo hueco Vis à six-pans creux	M8 x 20 25Nm/18ft.lbs	ISO4762
56	0010822	2	Hexagon nut Sechskantmutter	Tuerca hexagonal Écrou hexagonal	M30 x 1,5	DIN936
57	0010883	1	Hexagon nut Sechskantmutter	Tuerca hexagonal Écrou hexagonal		
58	0211790	1	Hexagon nut Sechskantmutter	Tuerca hexagonal Écrou hexagonal	M10LH	DIN934
59	0011437	2	Hexagonal head cap screw Sechskantschraube	Tornillo hexagonal Vis à tête hexagonale	M10 x 40 49Nm/36ft.lbs	DIN933
60	0010884	2	Hexagon nut Sechskantmutter	Tuerca hexagonal Écrou hexagonal	M12	DIN934
61	0210133	1	Bushing Buchse	Buje Douille		

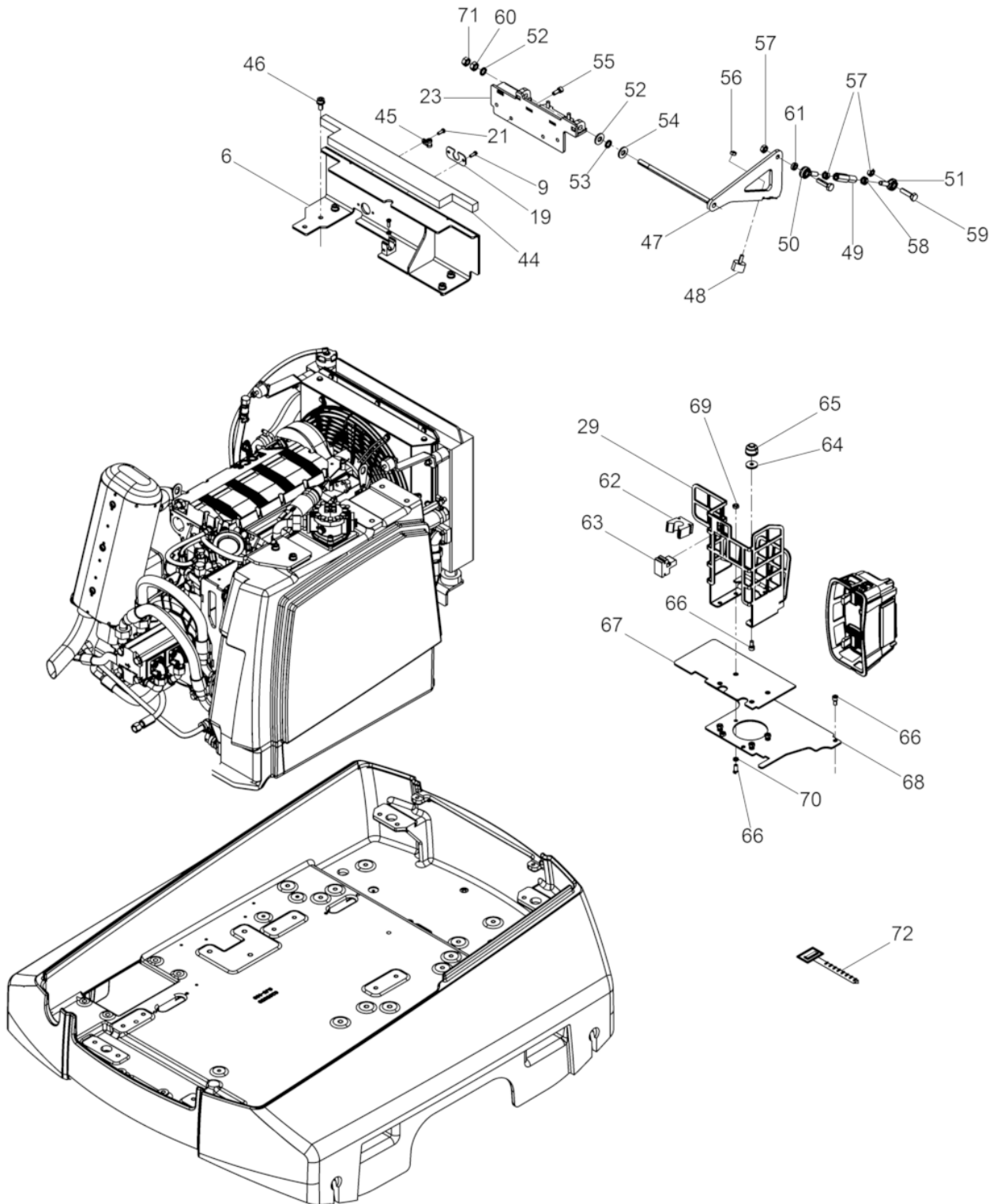

Ref. Pos.	Part No. Artikel Nr.	Qty. St.	Description Beschreibung	Descripción Description	Measurement./Abm.	Norm
					Torque/Drehm.	Sealant Schmierstoff
62	0208255	1	Bracket Halterung	Soporte Équerre		
63	0207753	1	Bracket Halterung	Soporte Équerre		
64	0031632	2	Washer Scheibe	Arandela Rondelle		
65	0105056	2	Shockmount Anschlagpuffer	Amortiguador Silentbloc	M30 x 20	
66	0011544	4	Cheese head screw Zylinderschraube	Tornillo cilíndrico Vis à tête cylindrique	M8 x 16 25Nm/18ft.lbs	ISO4762
67	0207749	1	Positive pol cover Pluspolabdeckung	Cubierta Couverture		
68	0210142	1	Cover Deckel kpl.	Tapa Couvercle		
69	0010882	6	Hexagon nut Sechskantmutter	Tuerca hexagonal Écrou hexagonal		
70	0212623	4	Bushing Buchse	Buje Douille		

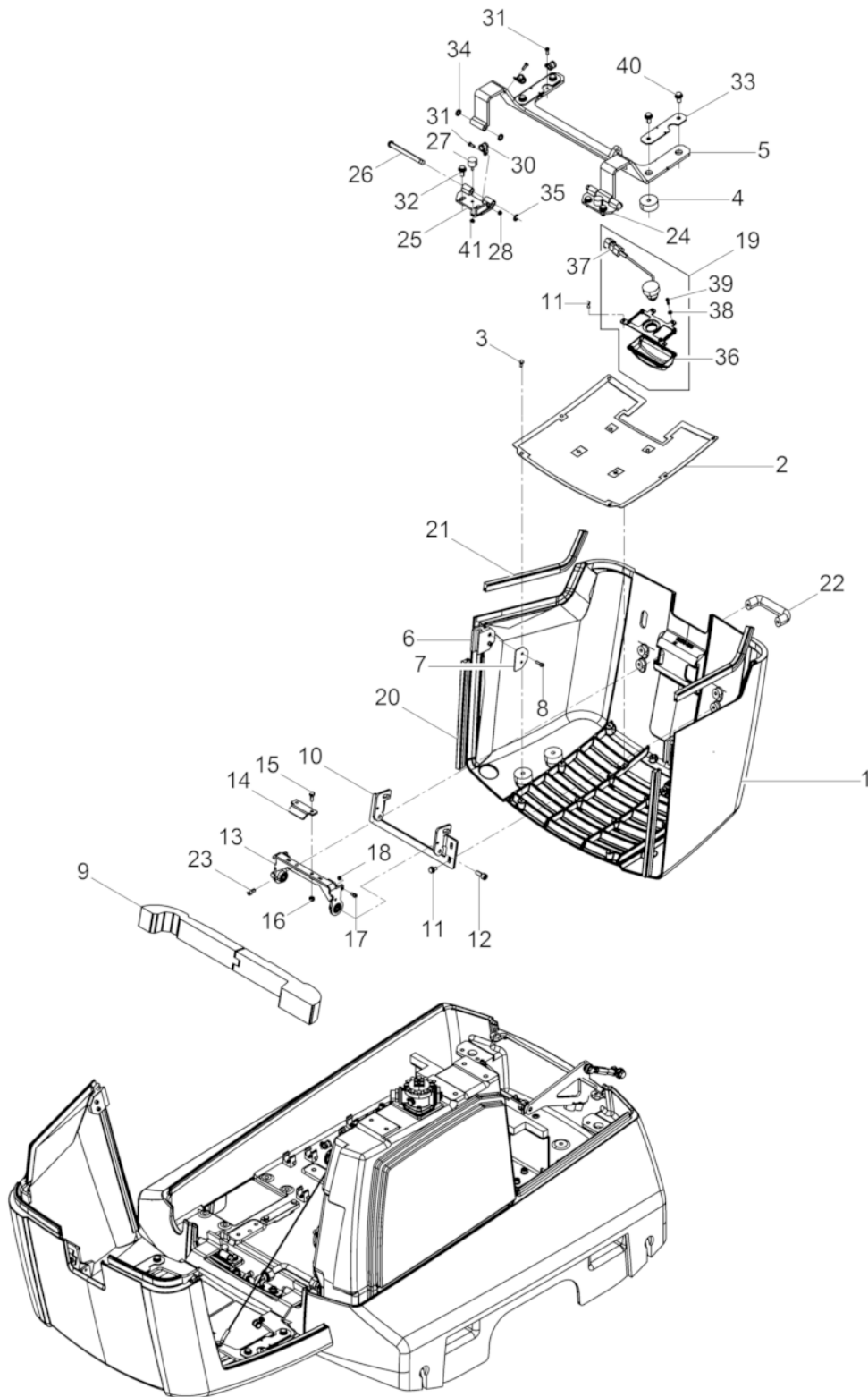

Ref. Pos.	Part No. Artikel Nr.	Qty. St.	Description Beschreibung	Descripción Description	Measurement./Abm.	Norm
					Torque/Drehm.	Sealant Schmierstoff
1	0206481	1	Bonnet rear Haube hinten	Cubierta atrás Capot arrière		
2	0208274	1	Grid Gitter	Rejilla Grille		
3	0204408	14	Screw Schraube	Tornillo Vis	DE M 6x 16	DIN7500
4	0206517	4	Shockmount Gummi-Metall-Puffer	Tope caucho-metal Tampon metallique oscillant	50 x 20	
5	0206509	1	Hinge Scharnier	Bisagra Charnière		
6	0205367	2	Fixation Fixierung	Fijación Fixation		
7	0207332	2	Reinforcement Verstärkung	Refuerzo Renforcement		
8	0011551	4	Cheese head screw Zylinderschraube	Tornillo cilíndrico Vis à tête cylindrique	10Nm/7ft.lbs	
9	0216573	1	Seal Abdichtung	Junta Joint		
10	0208287	1	Support Aufnahme	Asiento Support		
11	0211795	4	corrugated-head screw Sicherungsschraube	Tornillo Vis		
12	0011535	2	Cheese head screw Zylinderschraube	Tornillo cilíndrico Vis à tête cylindrique	49Nm/36ft.lbs	
13	0210122	1	Lever cpl. Hebel kpl.	Palanca cpl. Levier cpl.		
14	0209135	1	Plate Lasche	Eclisa Attache		
15	0012362	2	Hexagonal head cap screw Sechskantschraube	Tornillo hexagonal Vis à tête hexagonale	25Nm/18ft.lbs	
16	0033356	2	Hexagon nut Sechskantmutter	Tuerca hexagonal Écrou hexagonal		
17	0011554	2	Cheese head screw Zylinderschraube	Tornillo cilíndrico Vis à tête cylindrique	10Nm/7ft.lbs	
18	0021679	2	Hexagon nut Sechskantmutter	Tuerca hexagonal Écrou hexagonal	M6	DIN980
19	0209132	1	Receiver Unit rear Empfangseinheit hinten	Unidad Del Receptor atrás Unité De Récepteur arrière		
20	0211798	2	Edge protection Kantenschutzdichtprofil	Protección de cantos Protege arete	340 mm	
21	0211799	2	Edge protection Kantenschutzdichtprofil	Protección de cantos Protege arete	400 mm	
22	0210163	1	Handle Handgriff	Empuñadura Poignée		
23	0011544	2	Cheese head screw Zylinderschraube	Tornillo cilíndrico Vis à tête cylindrique	M8 x 16 25Nm/18ft.lbs	ISO4762
24	0206506	1	Hinge Scharnier	Bisagra Charnière		
25	0210141	1	Hinge Scharnier	Bisagra Charnière		

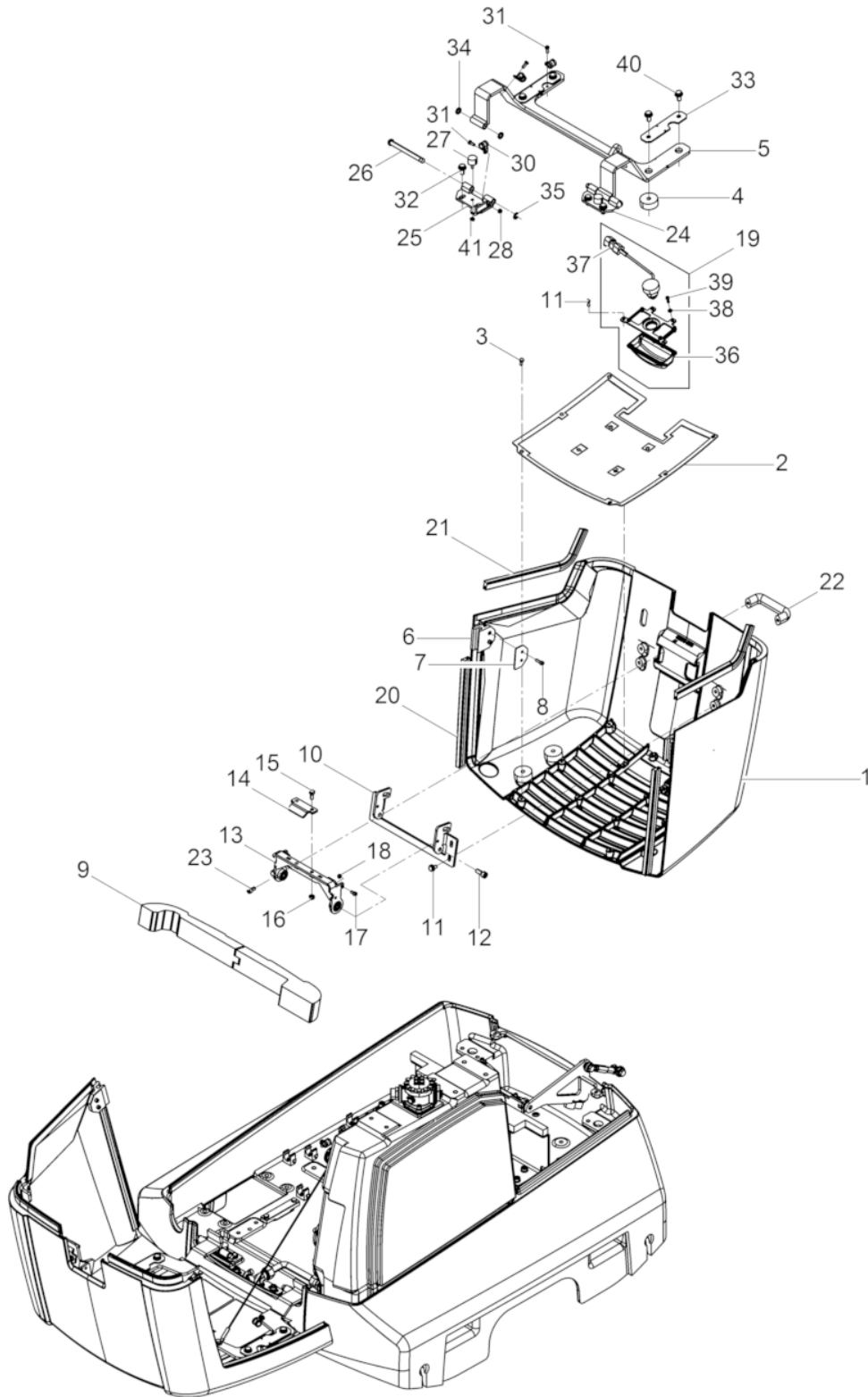

Ref. Pos.	Part No. Artikel Nr.	Qty. St.	Description Beschreibung	Descripción Description	Measurement./Abm.	Norm
					Torque/Drehm.	Sealant Schmierstoff
26	0220132	2	Bolt Bolzen	Perno Boulon		
27	0206525	2	Shockmount Anschlagpuffer	Amortiguador Silentbloc	25 x 17	
28	0021679	1	Hexagon nut Sechskantmutter	Tuerca hexagonal Écrou hexagonal	M6	DIN980
30	0212145	3	Clamp Rohrschelle	Abrazadera Agrafe	RSGU 1.13/15	
31	0211755	3	Screw Schraube	Tornillo Vis		
32	0210112	4	corrugated-head screw Sicherungsschraube	Tornillo Vis		
33	0207723	2	Plate Blech	Chapa Tôle		
34	0220172	4	Washer Scheibe	Disco Rondelle		
35	0020610	2	Lock washer Sicherungsscheibe	Arandela de seguridad Rondelle d'arrêt	9	DIN6799
36	0209126	1	Protective cap Schutzkappe	Capa de protección Capuchon de protection		
37	0170949	1	Infrared sensor Empfängerauge	Receptor de rayos Oeil récepteur		
38	0103211	4	Lockwasher Spannscheibe	Arandela elástica Rondelle de ressort	5	DIN6796
39	0208646	2	Cheese head screw Zylinderschraube	Tornillo cilíndrico Vis à tête cylindrique	M 5x 16	DIN7984
40	0210111	4	corrugated-head screw Sicherungsschraube	Tornillo Vis		
41	0010368	2	Hexagon nut Sechskantmutter	Tuerca hexagonal Écrou hexagonal	M6	DIN985

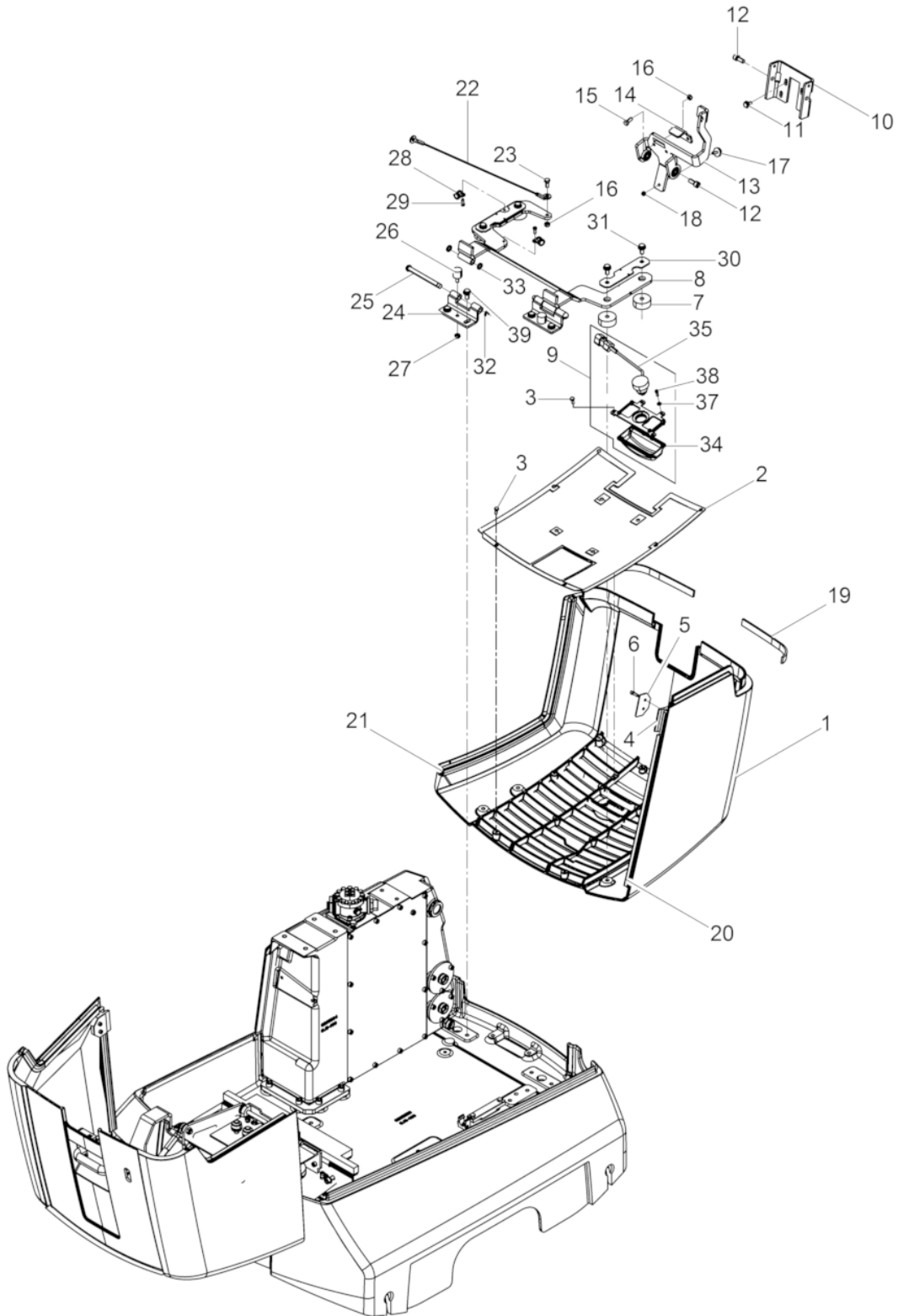

Ref. Pos.	Part No. Artikel Nr.	Qty. St.	Description Beschreibung	Descripción Description	Measurem./Abm.	Norm
					Torque/Drehm.	Sealant Schmierstoff
1	0206479	1	Bonnet front Haube vorne	Cubierta delantero Capot avant		
2	0208273	1	Grid Gitter	Rejilla Grille		
3	0204408	14	Screw Schraube	Tornillo Vis	DE M 6x 16	DIN7500
4	0205367	1	Fixation Fixierung	Fijación Fixation		
5	0207332	1	Reinforcement Verstärkung	Refuerzo Renforcement		
6	0011551	2	Cheese head screw Zylinderschraube	Tornillo cilíndrico Vis à tête cylindrique	10Nm/7ft.lbs	
7	0206517	4	Shockmount Gummi-Metall-Puffer	Tope caucho-metal Tampon metallique oscillant	50 x 20	
8	0206510	1	Hinge Scharnier	Bisagra Charnière		
9	0209131	1	Receiver Unit front Empfangseinheit vorne	Unidad Del Receptor delantero Unité De Récepteur avant		
10	0209110	1	Support Aufnahme	Asiento Support		
11	0211795	4	corrugated-head screw Sicherungsschraube	Tornillo Vis		
12	0011535	2	Cheese head screw Zylinderschraube	Tornillo cilíndrico Vis à tête cylindrique	49Nm/36ft.lbs	
13	0209138	1	Lever cpl. Hebel kpl.	Palanca cpl. Levier cpl.		
14	0209136	1	Plate Lasche	Eclisa Attache		
15	0011457	2	Hexagonal head cap screw Sechskantschraube	Tornillo hexagonal Vis à tête hexagonale	M8 x 25 25Nm/18ft.lbs	DIN933
16	0033356	3	Hexagon nut Sechskantmutter	Tuerca hexagonal Écrou hexagonal		
17	0058648	1	Shockmount Gummi-Metall-Puffer	Amortiguador Silentbloc		
18	0010368	1	Hexagon nut Sechskantmutter	Tuerca hexagonal Écrou hexagonal	M6 6.7Nm/5ft.lbs	DIN985
19	0209153	2	Seal Abdichtung	Junta Joint		
20	0211796	1	Edge protection Kantenschutzdichtprofil	Protección de cantos Protege arete	470 mm	
21	0211797	1	Edge protection Kantenschutzdichtprofil	Protección de cantos Protege arete	750 mm	
22	0154402	1	Cable Kabel	Cable Câble		
23	0012362	1	Hexagonal head cap screw Sechskantschraube	Tornillo hexagonal Vis à tête hexagonale	25Nm/18ft.lbs	
24	0206505	2	Hinge Scharnier	Bisagra Charnière		
25	0220132	2	Bolt Bolzen	Perno Boulon		

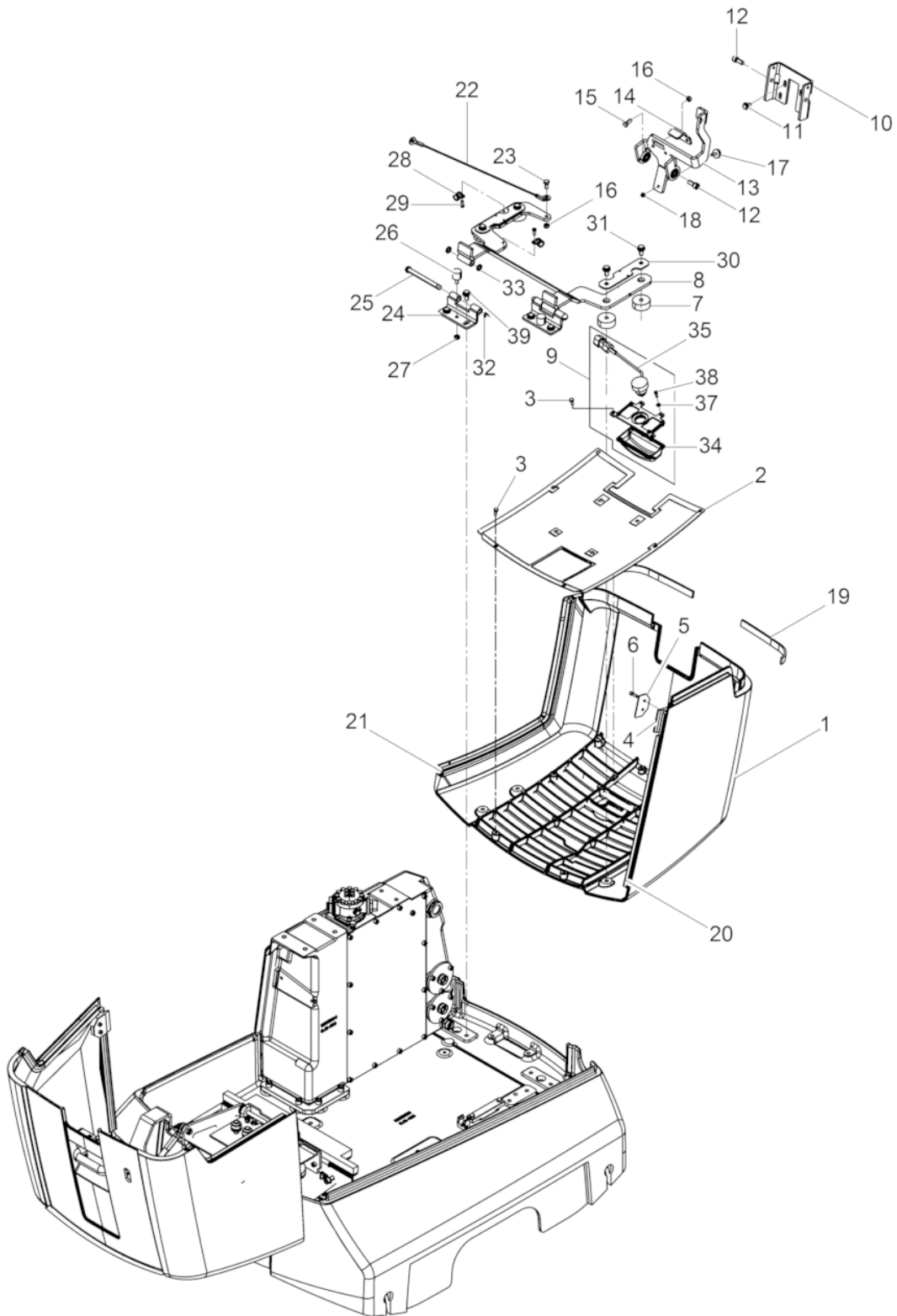

Ref. Pos.	Part No. Artikel Nr.	Qty. St.	Description Beschreibung	Descripción Description	Measur./Abm.	Norm
					Torque/Drehm.	Sealant Schmierstoff
26	5100001430	2	Shockmount Puffer	Tope Tampon	25x27 16Nm/12ft.lbs	
27	0010367	2	Hexagon nut Sechskantmutter	Tuerca hexagonal Écrou hexagonal	M8	DIN985
28	0212145	3	Clamp Rohrschelle	Abrazadera Agrafe	RSGU 1.13/15	
29	0211755	3	Screw Schraube	Tornillo Vis		
30	0207722	2	Plate Blech	Chapa Tôle		
31	0210112	4	corrugated-head screw Sicherungsschraube	Tornillo Vis		
32	0020610	2	Lock washer Sicherungsscheibe	Arandela de seguridad Rondelle d'arrêt	9	DIN6799
33	0220172	4	Washer Scheibe	Disco Rondelle		
34	0209112	1	Protective cap Schutzkappe	Capa de protección Capuchon de protection		
35	0170949	1	Infrared sensor Empfängerauge	Receptor de rayos Oeil récepteur		
37	0103211	4	Lockwasher Spannscheibe	Arandela elástica Rondelle de ressort	5	DIN6796
38	0208646	2	Cheese head screw Zylinderschraube	Tornillo cilíndrico Vis à tête cylindrique	M 5x 16	DIN7984
39	0210111	4	corrugated-head screw Sicherungsschraube	Tornillo Vis		

Hydraulic Tank cpl.
Hydrauliktank kpl.
Tanque Hidráulico cpl.
Réservoir Hydraulique cpl.

DPU 130Le

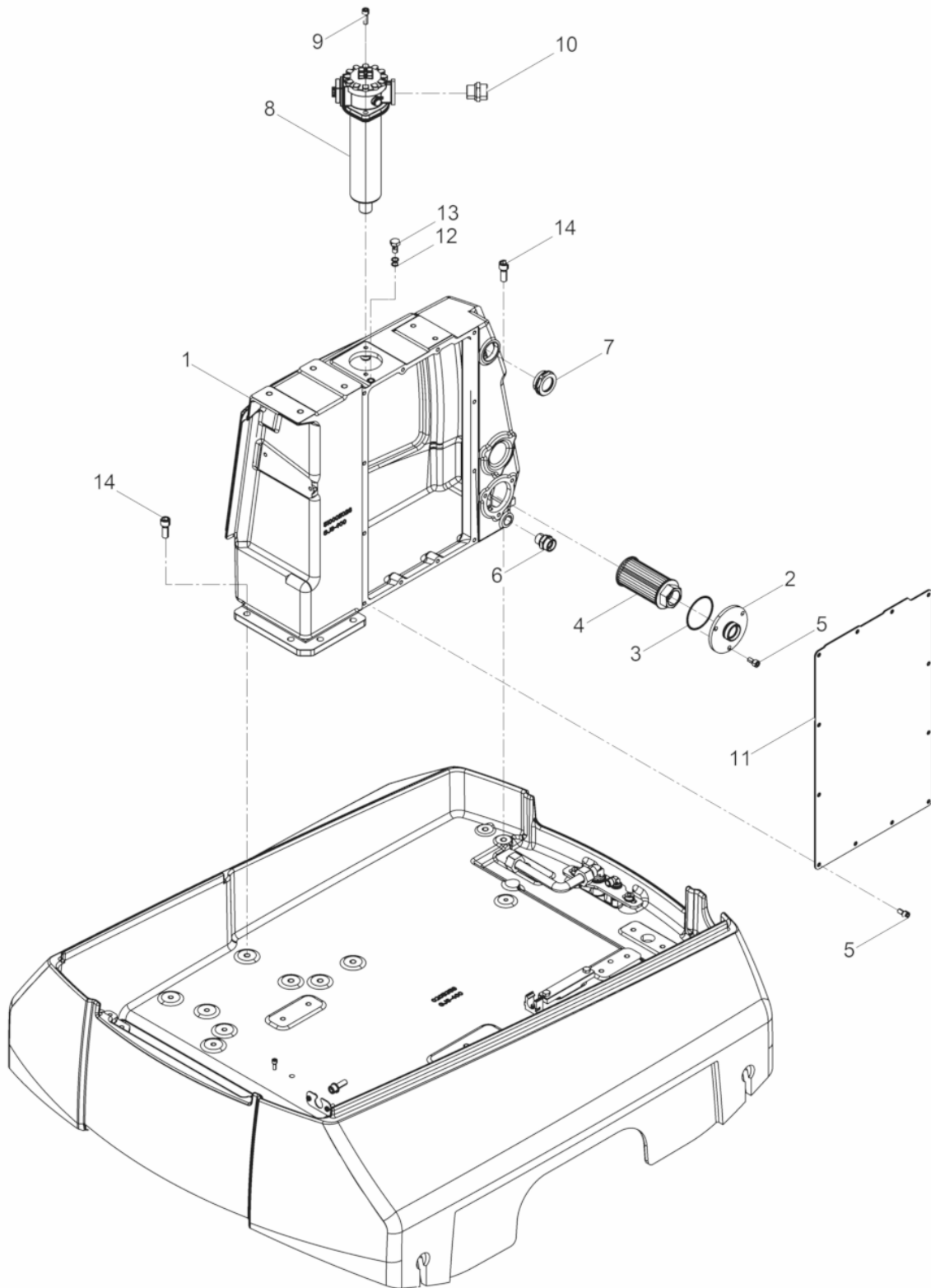

Ref. Pos.	Part No. Artikel Nr.	Qty. St.	Description Beschreibung	Descripción Description	Measurem./Abm.	Norm
					Torque/Drehm.	Sealant Schmierstoff
1	5100011027	1	Hydraulic Tank Hydrauliktank	Tanque Hidráulico Réservoir Hydraulique		
2	5100004411	1	intake neck Ansaugstutzen	boquilla de succión de la bombomba Manchon		
3	0017734	1	O-ring O-Ring	Anillo-O Bague-O	65 x 3	
4	0205917	1	Filter Element Filterelement	Elemento del Filtro Élément du Filtre		
5	0011544	15	Cheese head screw Zylinderschraube	Tornillo cilíndrico Vis à tête cylindrique	M8 x 16 25Nm/18ft.lbs	ISO4762
6	0063739	1	Screwed socket Einschraubstutzen	Empalme roscado Manchon visse		DIN3901
7	0205918	1	Oil Sight Glass Ölschauglas	Mirilla Del Nivel de Aceite Indicateur de Niveau		
8	0206497	1	Return filter Rücklauffilter	Filtro de retorno Filtre de retour		
9	0011542	2	Cheese head screw Zylinderschraube	Tornillo cilíndrico Vis à tête cylindrique	25Nm/18ft.lbs	
10	0046094	1	Screwed socket Einschraubstutzen	Empalme roscado Manchon visse		DIN3901
11	0204115	1	Cover Deckel	Cubierta Couvercle		
12	0020071	2	Gasket Dichtring	Anillo de junta Bague d'étanchéité	A10 x 14	DIN7603
13	0046916	1	Banjo bolt Hohlschraube	Perno hueco Boulon creux à filet femelle	6-3	DIN7643
14	0011529	6	Cheese head screw Zylinderschraube	Tornillo cilíndrico Vis à tête cylindrique	M12 x 30 86Nm/63ft.lbs	ISO4762

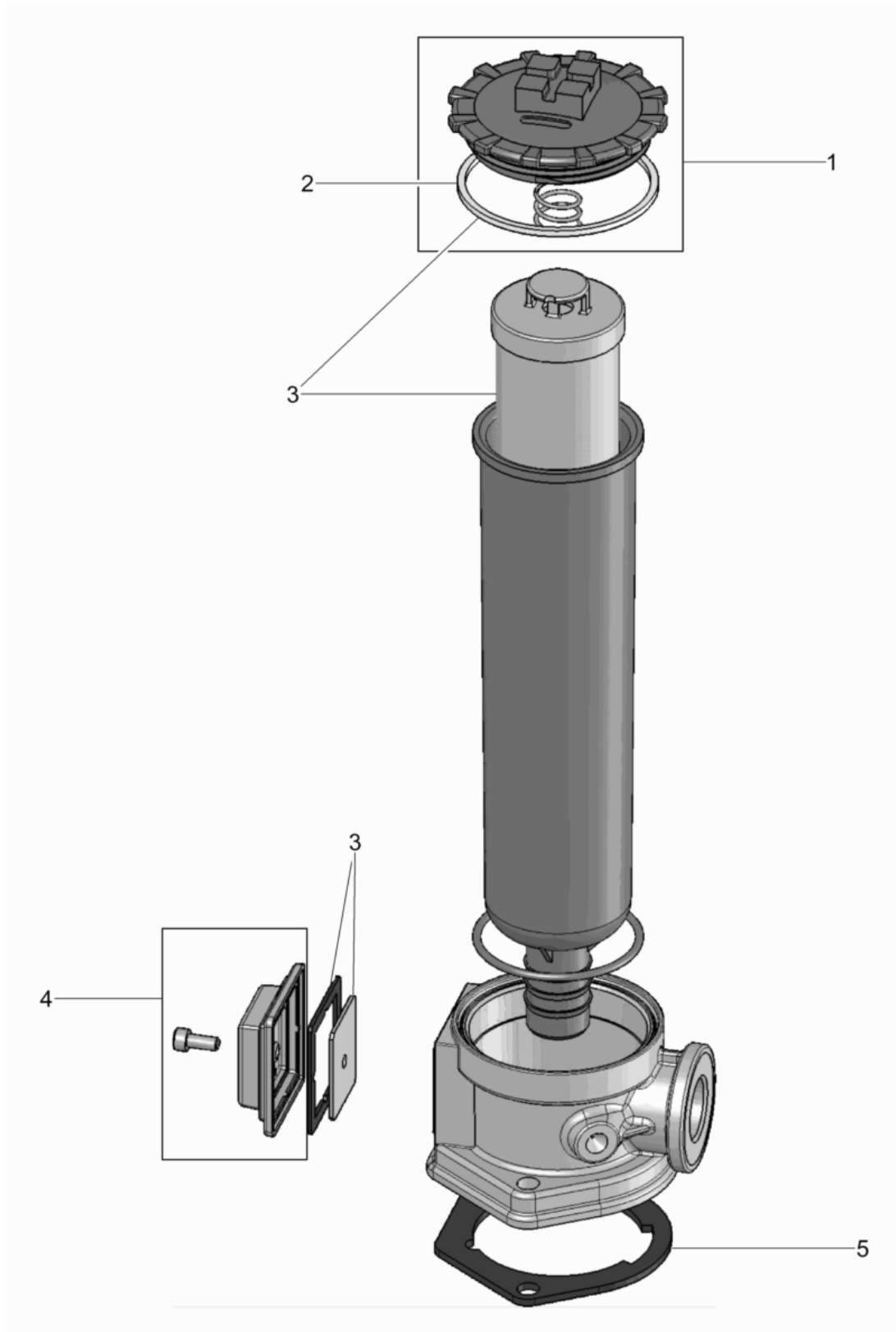

Ref. Pos.	Part No. Artikel Nr.	Qty. St.	Description Beschreibung	Descripción Description	Measurement./Abm.	Norm
					Torque/Drehm.	Sealant Schmierstoff
1	0220217	1	Cover Deckel kpl.	Tapa Couvercle		
2	0220218	1	Gasket Dichtung	Junta de estanqueidad Garniture		
3	0220219	1	Hydraulic filter element Kit Filterelementsatz	Elemento del filtro hidráulicadráulico Élément du filtre hydraulique		
4	0220221	1	Cover Deckel	Cubierta Couvercle		
5	0220222	1	Gasket Dichtung	Junta de estanqueidad Garniture		

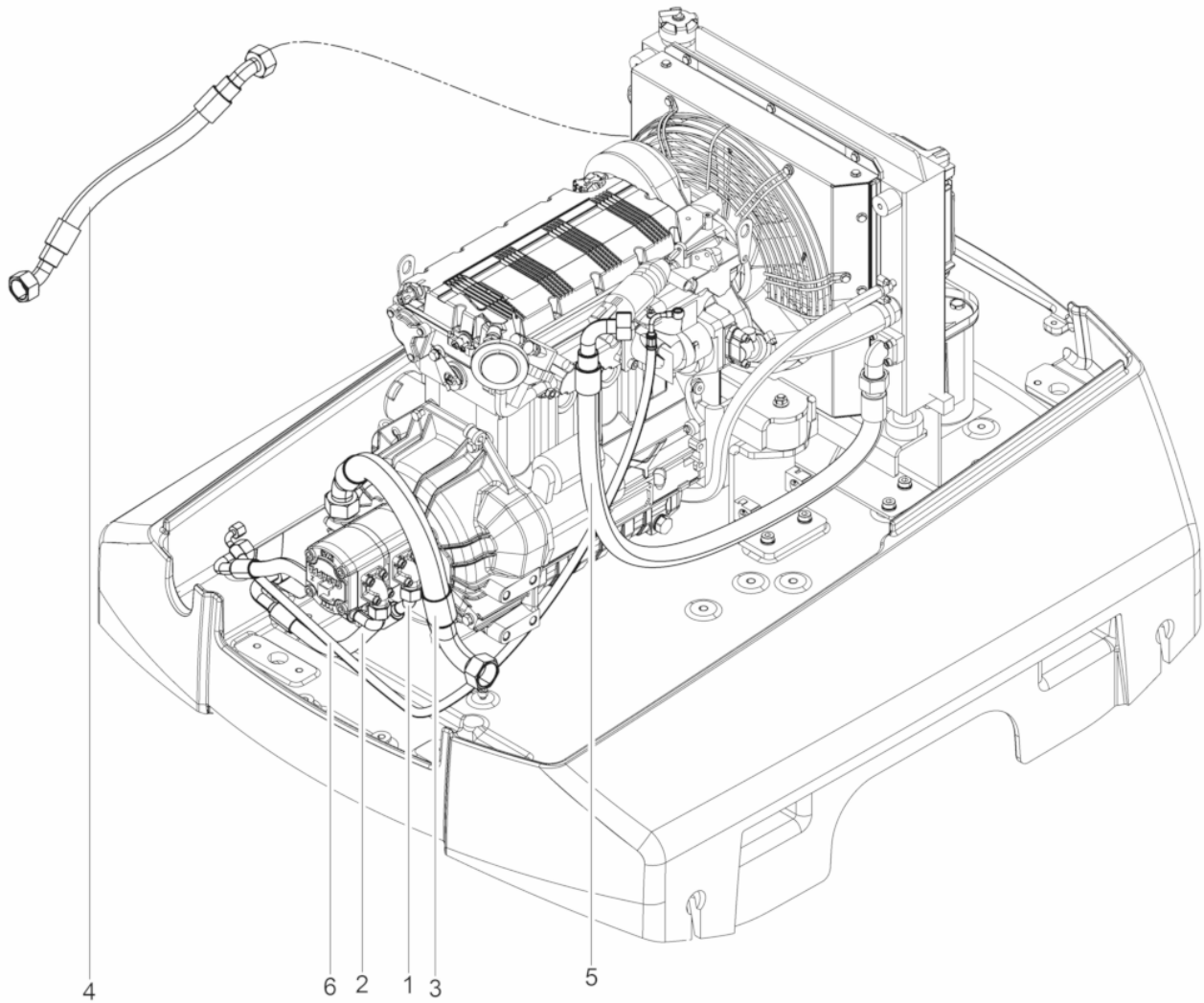

Ref. Pos.	Part No. Artikel Nr.	Qty. St.	Description Beschreibung	Descripción Description	Measurement./Abm.	Norm
					Torque/Drehm.	Sealant Schmierstoff
1	0206456	1	Hose pipe Schlauchleitung	Conducto flexible Conduite flexible		
2	0206457	1	Hose pipe Schlauchleitung	Conducto flexible Conduite flexible		
3	5100005816	1	Hose pipe Schlauchleitung	Conducto flexible Conduite flexible		
4	0206466	1	Hose pipe Schlauchleitung	Conducto flexible Conduite flexible		
5	0206467	1	Hose pipe Schlauchleitung	Conducto flexible Conduite flexible		
6	0208239	1	Breather tube Entlüftungsleitung	Línea de purgado Tuyau d'évacuation purge		

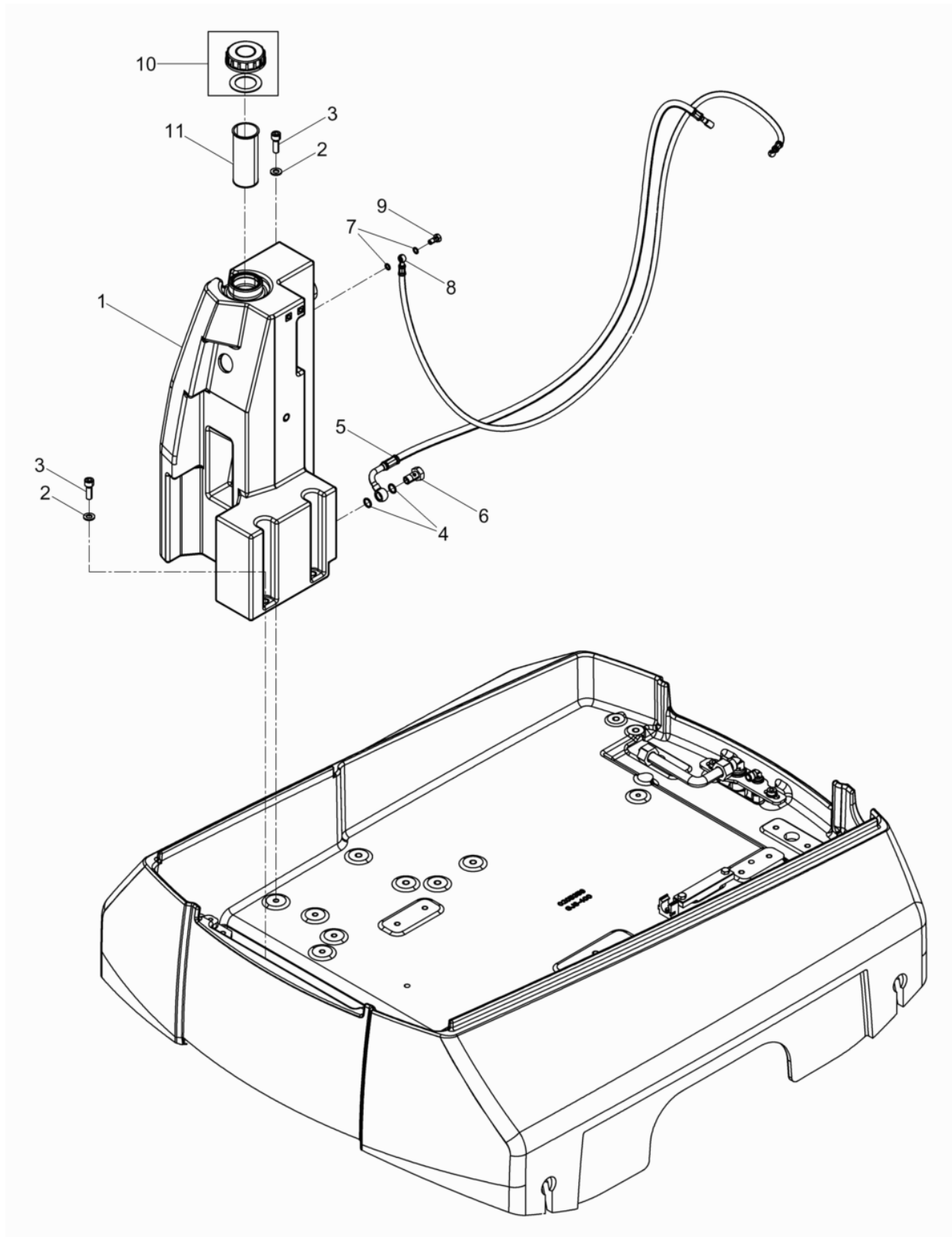

Ref. Pos.	Part No. Artikel Nr.	Qty. St.	Description Beschreibung	Descripción Description	Measurement./Abm.	Norm
					Torque/Drehm.	Sealant Schmierstoff
1	0206440	1	Fuel Tank Kraftstofftank	Depósito de Combustible Réservoir à Essence		
2	0010621	4	Washer Scheibe	Arandela Rondelle		
3	0011534	4	Cheese head screw Zylinderschraube	Tornillo cilíndrico Vis à tête cylindrique	M10 x 30 49Nm/36ft.lbs	ISO4762
4	0012624	2	Gasket Dichtring	Anillo de junta Bague d'étanchéité	A14 x 18	DIN7603
5	0206443	1	Fuel hose Kraftstoffleitung	Manguera de combustible Tuyau à essence		
6	0043201	1	Banjo bolt Hohlschraube	Perno hueco Boulon creux à filet femelle	10-3	DIN7643
7	0012491	2	Gasket Dichtring	Anillo de junta Bague d'étanchéité	A8 x 12	DIN7603
8	0206444	1	Fuel hose Kraftstoffleitung	Manguera de combustible Tuyau à essence		
9	0034365	1	Banjo bolt Hohlschraube	Perno hueco Boulon creux à filet femelle	4-3	DIN7643
10	0206441	1	Tank cover Tankdeckel	Tapa de tanque Couvercle du réservoir		
11	0206442	1	Strainer Sieb	Colador Crépine		

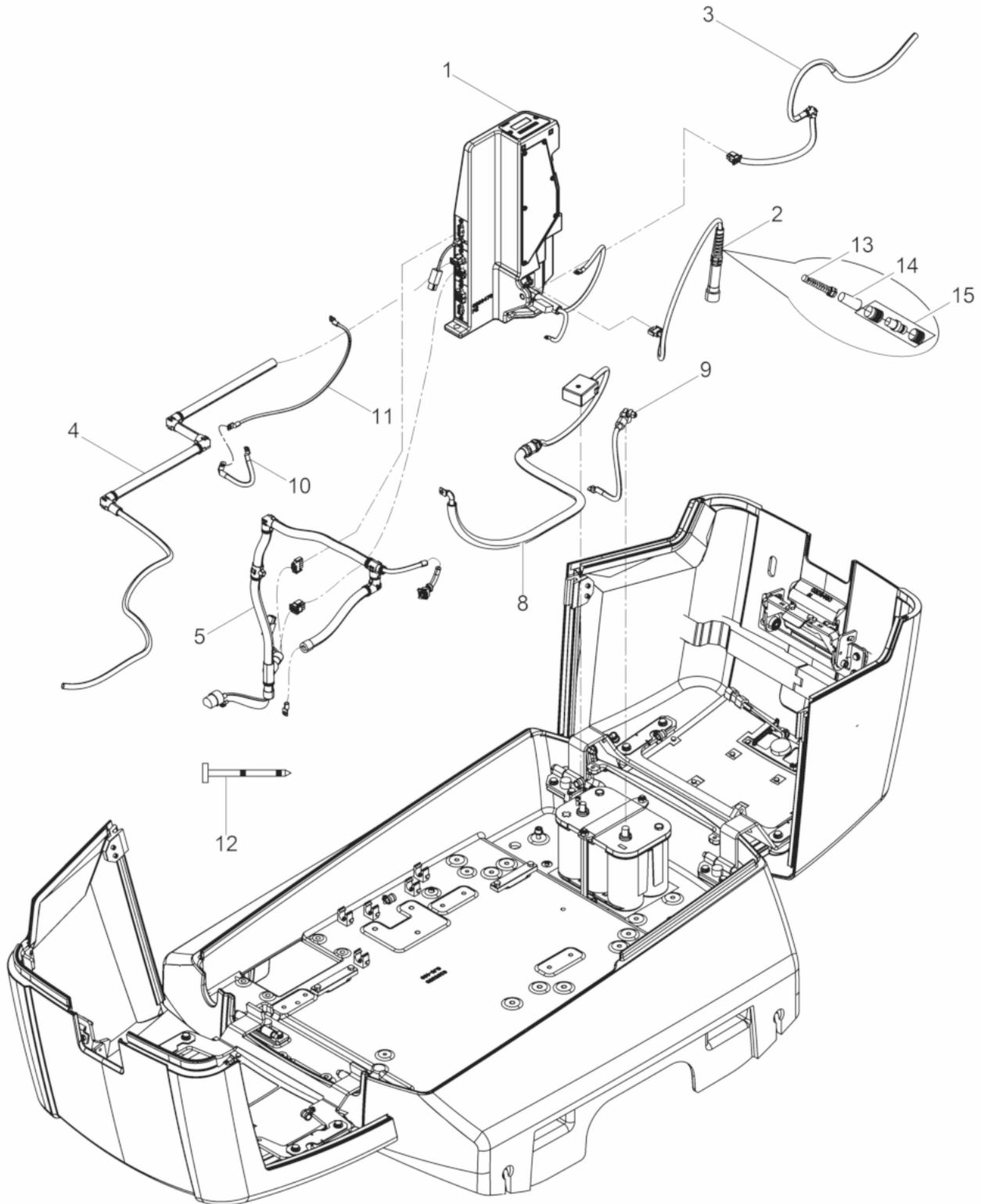

Ref. Pos.	Part No. Artikel Nr.	Qty. St.	Description Beschreibung	Descripción Description	Measurement./Abm.	Norm
					Torque/Drehm.	Sealant Schmierstoff
1	0206469	1	Electric box cpl. Elektrobox kpl.	Caja eléctrica cpl. Coffret électrique cpl.		
2	0206492	1	Helix cable Spiralkabel	Cable espiral Câble spirale		
3	0206487	1	Cable harness Receiver rear Kabelbaum Empfänger hinten	Disp. del cable de elevación Receptor atrás Faisceau de câbles Recepteur		
4	0209125	1	Cable harness Receiver front Kabelbaum Empfänger vorne	Disp. del cable de elevación Receptor delantero Faisceau de câbles Recepteur		
5	5100006132	1	Cable harness Kabelbaum	Disp. del cable de elevación Faisceau de câbles		
8	5100028088	1	Positive pole strap cpl. Plus-Pol-Leitung kpl.	Cable polo positivo cpl. Ligne borne positive cpl.		
9	5100028089	1	Negative pole strap cpl. Minus-Pol-Leitung kpl.	Cable polo negativo cpl. Ligne borne négative cpl.		
10	0206477	1	Mass line Masseleitung	Cable de masa Câble de mise à la masse		
11	0207755	1	Mass line Masseleitung	Cable de masa Câble de mise à la masse		
12	0047388	25	Cable yarn Kabelbinder	Fijación de cables Attache de câble		
13	0089676	2	Strain relief Zugentlastung	Alivio de esfuerzos Effort à la décharge		
14	0088821	2	Adaptor Adapter	Adaptador Adaptateur		
15	0116889	2	Plug cpl. Stopfen kpl.	Tapón compl Bouchon compl		

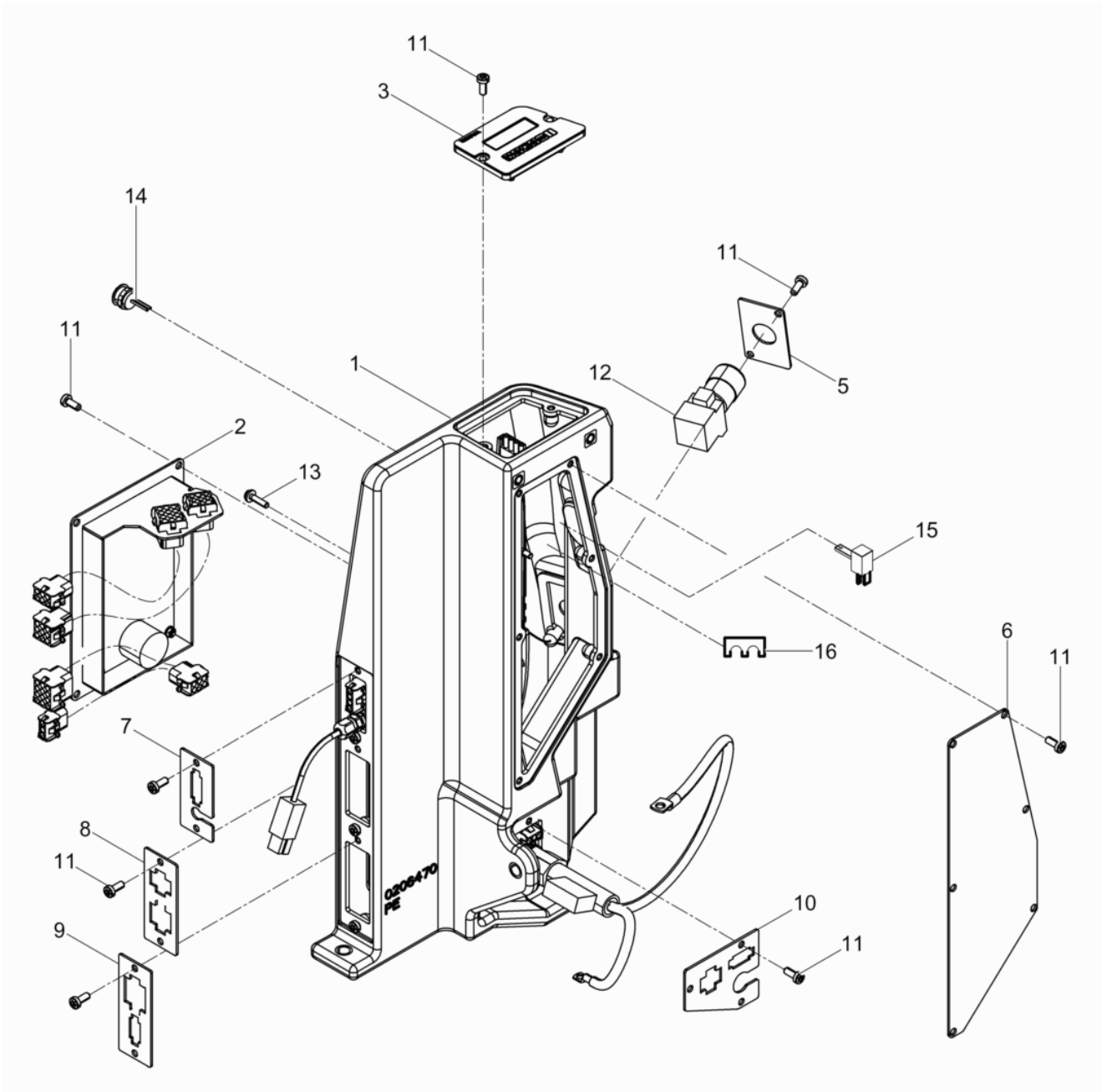

Ref. Pos.	Part No. Artikel Nr.	Qty. St.	Description Beschreibung	Descripción Description	Measurem./Abm.	Norm
					Torque/Drehm.	Sealant Schmierstoff
1	0220223	1	Electric box preassembled Elektrobox vormontiert	Caja eléctrica Coffret électrique		
2	0206431	1	Decoder cpl. Dekoder kpl.	Decodificador cpl. Décodeur cpl.		
3	0208240	1	Display Anzeigeneinheit	Cuadro indicador Afficheur, écran		
5	0206474	1	Plate Blech	Chapa Tôle		
6	0206471	1	Cover Deckel	Cubierta Couvercle		
7	0206472	1	Control Steckerblech	Regulador Commande		
8	0206473	1	Control Steckerblech	Regulador Commande		
9	0209148	1	Control Steckerblech	Regulador Commande		
10	0207724	1	Control Steckerblech	Regulador Commande		
11	0108371	23	Oval head screw Linsenkopfschraube	Tornillo gota de sebo Vis noyée lentiforme		
12	0206482	1	emergency stop switch Not-Aus Schalter	Interruptorencia coffret arrêt d'urgence vide		
13	0210175	2	corrugated-head screw Sicherungsschraube	Tornillo Vis	M 5x 12	
14	0216563	1	Botton switch Drucktaster	Interruptor a pulsador Interrupteur de pression		
15	0085437	2	Relay Relais	Relai Relais		
16	0220215	1	fuse Sicherung	Fusible el fusible	80A	

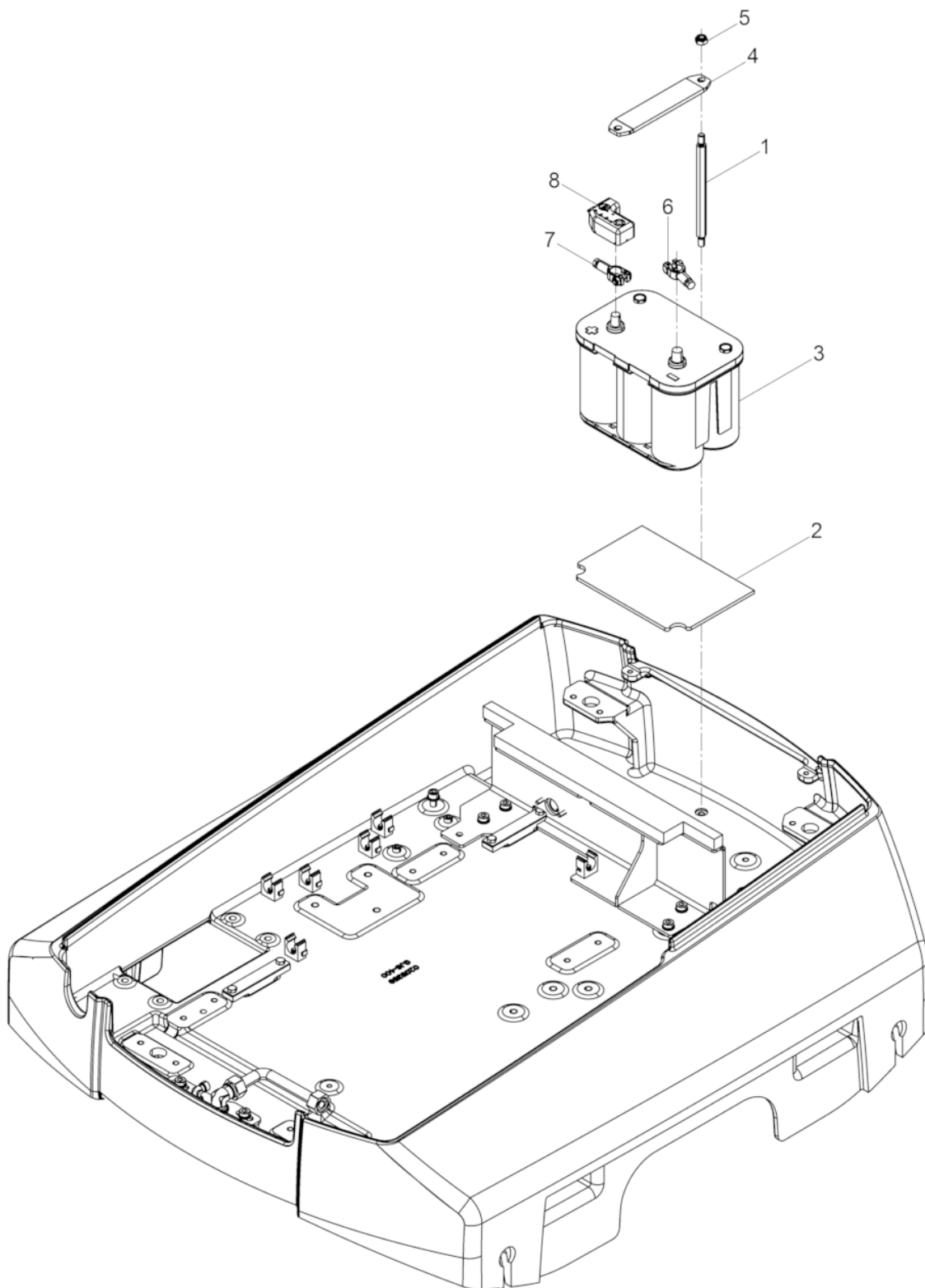

Ref. Pos.	Part No. Artikel Nr.	Qty. St.	Description Beschreibung	Descripción Description	Measurem./Abm.	Norm
					Torque/Drehm.	Sealant Schmierstoff
1	0206534	2	Threaded bolt Gewindebolzen	Perno roscado Boulon fileté		
2	0209152	1	Insulating cushion Kissen	Almohadilla Coussin		
3	0086527	1	Battery Batterie	Batería Batterie		
4	0210157	1	Duct Blech kpl.	Cubierta Canal d'air		
5	0017313	2	Hexagon nut Sechskantmutter	Tuerca hexagonal Écrou hexagonal		
6	5100015203	1	pole terminal negative Polklemme Minuspol	terminal de polo negativo borne polaire negative		
7	5100015202	1	pole terminal positive Polklemme Pluspol	terminal de polo positivo borne polaire positive		
8	5100014022	1	Positive pol cover Pluspolabdeckung	Tapa polo positivo Couverture		

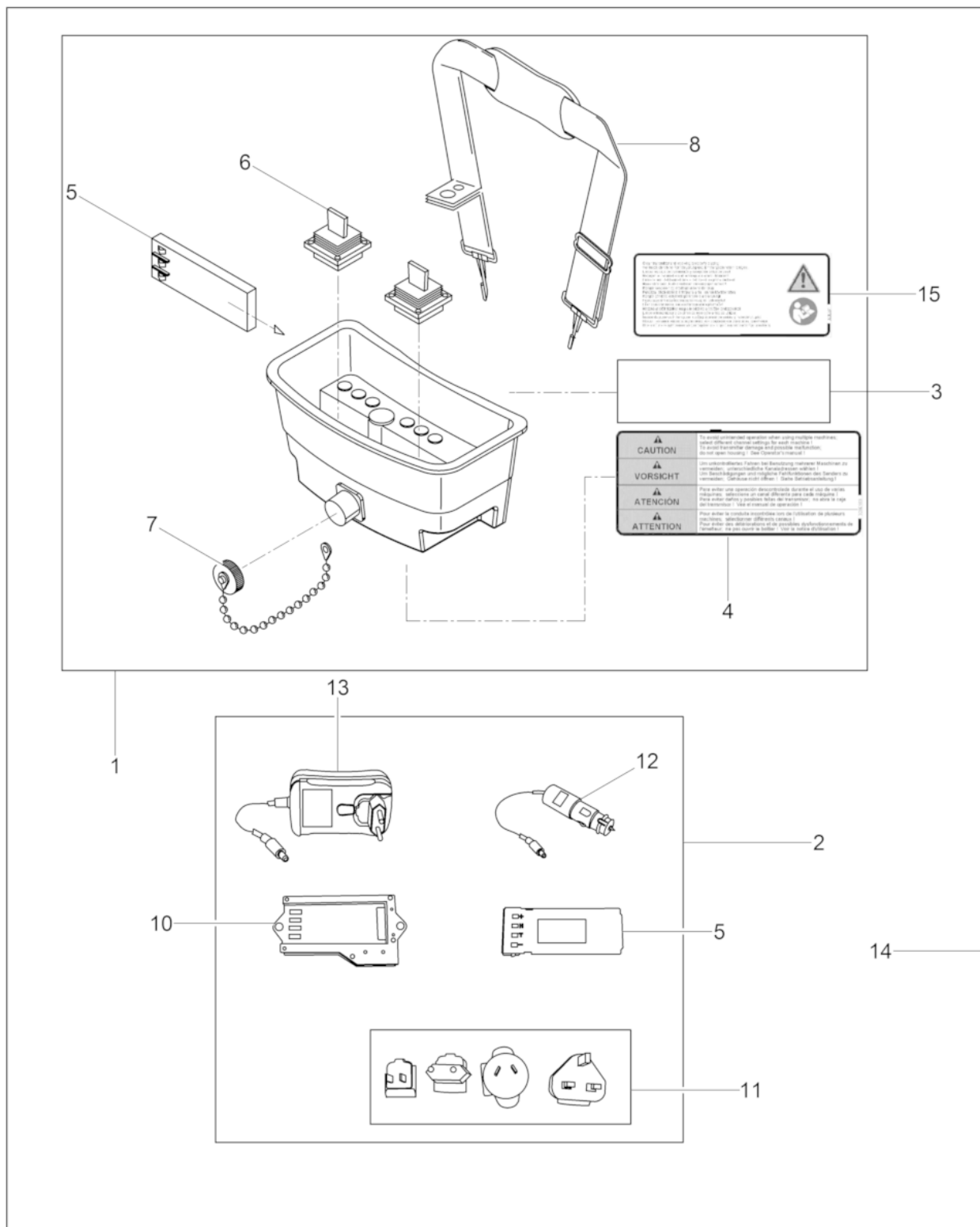

Ref. Pos.	Part No. Artikel Nr.	Qty. St.	Description Beschreibung	Descripción Description	Measurem./Abm.	Norm
					Torque/Drehm.	Sealant Schmierstoff
1	0206484	1	Transmitter Sender	Transmisor Transmetteur		
2	0213091	1	Charging Set Ladegerät	Juego de carga Jeu de charge		
3	0209157	1	Label-warning Aufkleber-Warnung	Calcomania-Advertencia Autocollant-Avertissement		
4	0209158	1	Instruction Label Aufkleber-Hinweis	Calcomanía-Indicación Autocollant avec Indication		
5	0210156	1	Battery Akku	Batería Accumalteur		
6	0177083	2	Steering Lever Kit Steuerhebel-Satz	Palanca de Dirección-Juego Levier de Direction-Jeu		
7	0117184	1	Cap Kappe	Tapa Couvercle		
8	0114783	1	Band Band	Cinta Ruban		
10	0209760	1	Battery charger Ladegerät	Cargador par batería Chargeur de batteries		
11	0209762	1	Plug Adapter Set Steckeradapter-Set	Enchufe de alimentación Mains plug		
12	0209763	1	Power cable Anschlusskabel	Cable de alimentación Cable d'alimentation		
13	0209761	1	Electrical plug Steckernetzteil	Enchufe de alimentación Mains plug		
14	0213092	1	Transmitter cpl. Sender kpl.	Transmisor cpl. Transmetteur cpl.		
15	5000226261	1	Label Aufkleber	Calcomania Autocollant		

Centre cross bar
Mitteltraverse
Travesaño central
Entretoise

DPU 130Le

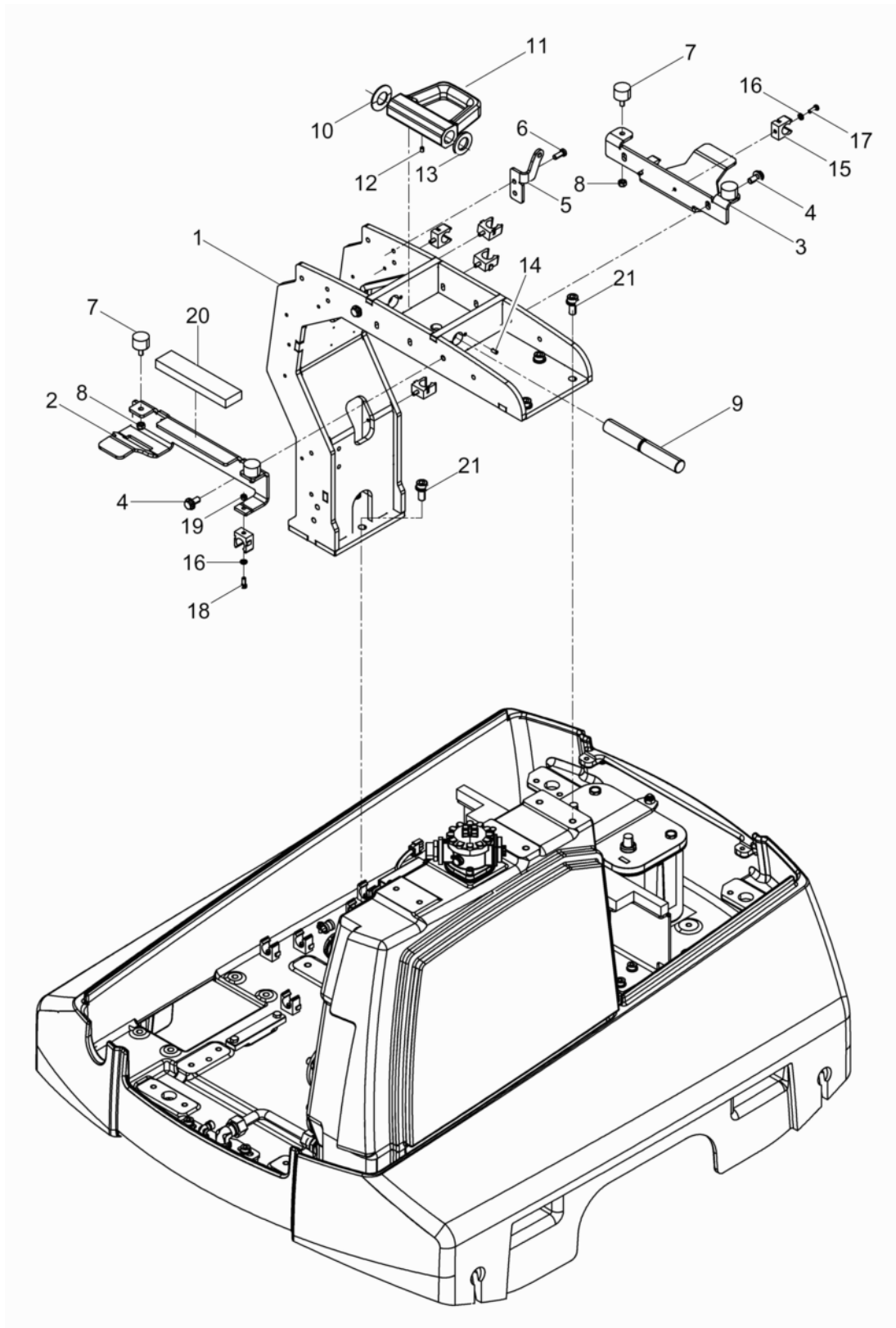

Ref. Pos.	Part No. Artikel Nr.	Qty. St.	Description Beschreibung	Descripción Description	Measurem./Abm.	Norm
					Torque/Drehm.	Sealant Schmierstoff
1	0203947	1	Centre cross bar Mitteltraverse	Travesaño central Entretoise		
2	0209111	1	Limit stop Anschlag	Dispositivo limitador Dispositif limiteur		
3	0208288	1	Limit stop Anschlag	Dispositivo limitador Dispositif limiteur		
4	0210112	4	corrugated-head screw Sicherheitsschraube	Tornillo Vis		
5	0207742	1	Cap Verschluss	Tapa Couvercle		
6	0211756	2	Screw Schraube	Tornillo Vis	M 8x 20	DIN7500
7	0204116	4	Shockmount Anschlagpuffer	Amortiguador Silentbloc		
8	0033356	4	Hexagon nut Sechskantmutter	Tuerca hexagonal Écrou hexagonal		
9	0203957	1	Axle Achse	Eje Axe		
10	0012108	1	Cup spring Tellerfeder	Resorte de platillo Ressort belleville	B 50,0 GR 2	DIN2093
11	0203956	1	Jack ring Kranöse	Ojete para grua Oeillet		
12	0127916	1	Threaded pin Gewindestift	Varilla roscada Goupille fileté	M 6x10	DIN914
13	0010614	1	Flat washer Scheibe	Arandela Rondelle	24	ISO7090
14	0126187	2	Threaded pin Gewindestift	Varilla roscada Goupille fileté		
15	0210107	7	Clamp Schlauchklemme	Abrazadera Collier de serrage		
16	0010624	7	Flat washer Scheibe	Arandela Rondelle		
17	0211755	6	Screw Schraube	Tornillo Vis		
18	0069425	1	Cheese head screw Zylinderschraube	Tornillo cilíndrico Vis à tête cylindrique	M6 x 16 10Nm/7ft.lbs	DIN7984
19	0021679	1	Hexagon nut Sechskantmutter	Tuerca hexagonal Écrou hexagonal	M6	DIN980
20	0209139	1	Seal Abdichtung	Junta Joint		
21	0210165	7	corrugated-head screw Sicherheitsschraube	Tornillo Vis		

Diesel Engine cpl.
Dieselmotor kpl.
Motor Diesel cpl.
Moteur Diesel cpl.

DPU 130Le

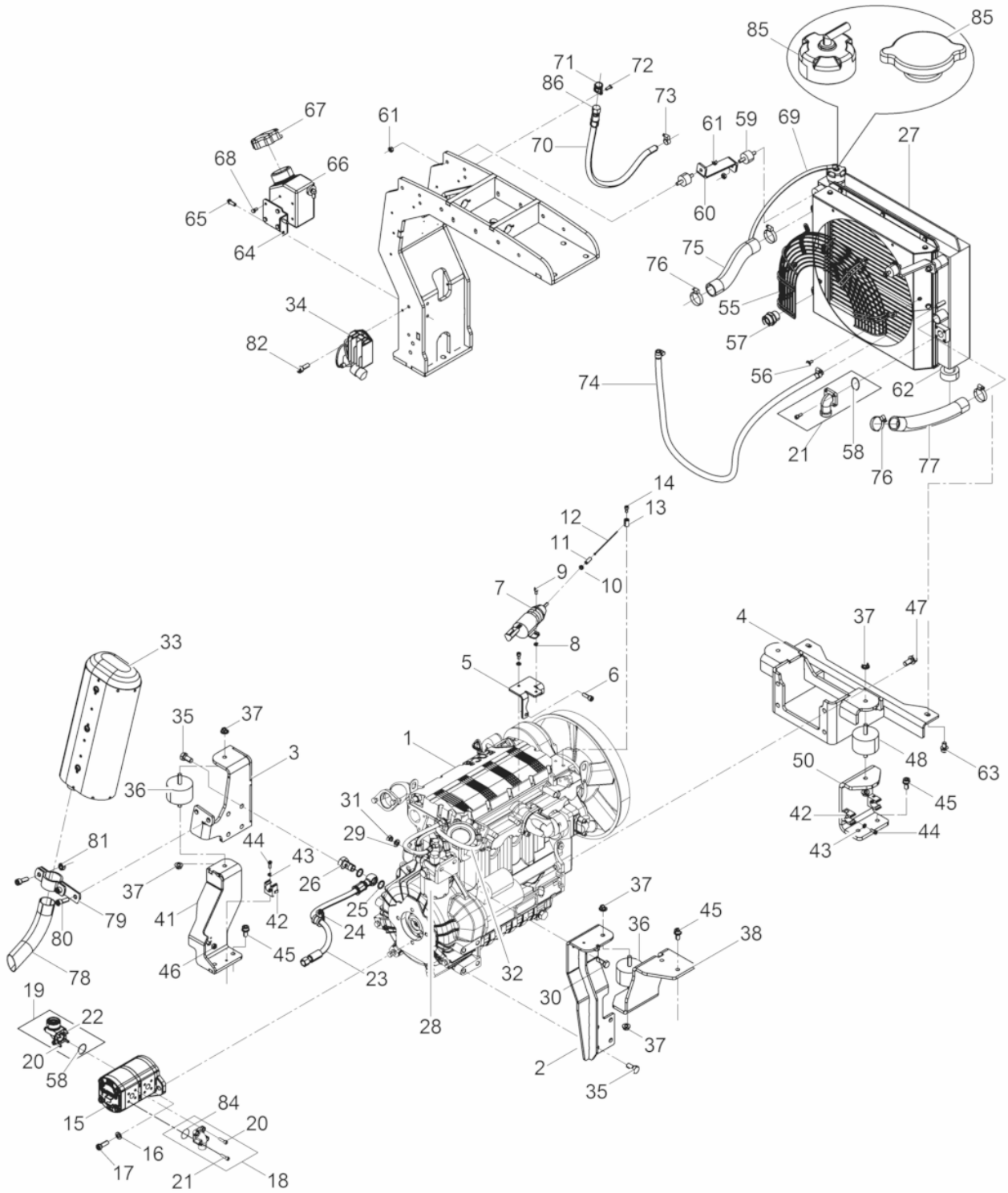

Ref. Pos.	Part No. Artikel Nr.	Qty. St.	Description Beschreibung	Descripción Description	Measurement./Abm.	Norm
					Torque/Drehm.	Sealant Schmierstoff
1	5100006033	1	Diesel engine Dieselmotor	Motor diesel Moteur diesel		
2	0203946	1	Engine Support Motorträger	Montaje del Motor Montage du Moteur		
3	5100031305	1	Bracket-shockmount cpl. Pufferkonsole kpl.	Soporte de amortiguador cpl. Support de silentbloc cpl.		
4	0203942	1	Engine Support Motorträger	Montaje del Motor Montage du Moteur		
5	0204549	1	Bracket Halter	Soporte Équerre		
6	0011542	2	Cheese head screw Zylinderschraube	Tornillo cilíndrico Vis à tête cylindrique	25Nm/18ft.lbs	
7	0155486	1	Throttle Actuator Gasreglerstellteil	Actuador de Acelerador Dispositif de commande des gaz		
8	0010624	2	Flat washer Scheibe	Arandela Rondelle		
9	0011554	2	Cheese head screw Zylinderschraube	Tornillo cilíndrico Vis à tête cylindrique	10Nm/7ft.lbs	
10	0010880	1	Hexagon nut Sechskantmutter	Tuerca hexagonal Écrou hexagonal		
11	0155487	1	Adaptor Adapter	Adaptador Adaptateur		
12	0150022	1	Cable Kabel	Cable Câble		
13	0119695	1	Collar Hülse	Collar Douille		
14	5100009861	1	Threaded pin Gewindestift	Varilla roscada Goupille fileté	3Nm/2ft.lbs	
15	5100005719	1	Gear pump Zahnradpumpe	Bomba de engranajes Pompe d'engrenages		
16	0010621	2	Washer Scheibe	Arandela Rondelle		
17	5100009846	2	Cheese head screw Zylinderschraube	Tornillo cilíndrico Vis à tête cylindrique	M10x 30 49Nm/36ft.lbs	
18	5100046101	2				
19	5100005817	1	Angular connection Winkel-Verschraubung	Atornilladura angular Fixation à angulaire	L 28	
20	0011552	6	Cheese head screw Zylinderschraube	Tornillo cilíndrico Vis à tête cylindrique	M6 x 18 10Nm/7ft.lbs	ISO4762
21	0011548	4	Cheese head screw Zylinderschraube	Tornillo cilíndrico Vis à tête cylindrique		
22	0011546	2	Cheese head screw Zylinderschraube	Tornillo cilíndrico Vis à tête cylindrique	M6 x 45 10Nm/7ft.lbs	ISO4762
23	0206577	1	Hose pipe Schlauchleitung	Conducto flexible Conduite flexible		
24	2006921	1	Pipe clamp Rohrschelle	Abrazadera Collier pour tuyau		
25	0019156	2	Gasket Dichtring	Anillo de junta Bague d'étanchéité		

Diesel Engine cpl.
Dieselmotor kpl.
Motor Diesel cpl.
Moteur Diesel cpl.

DPU 130Le

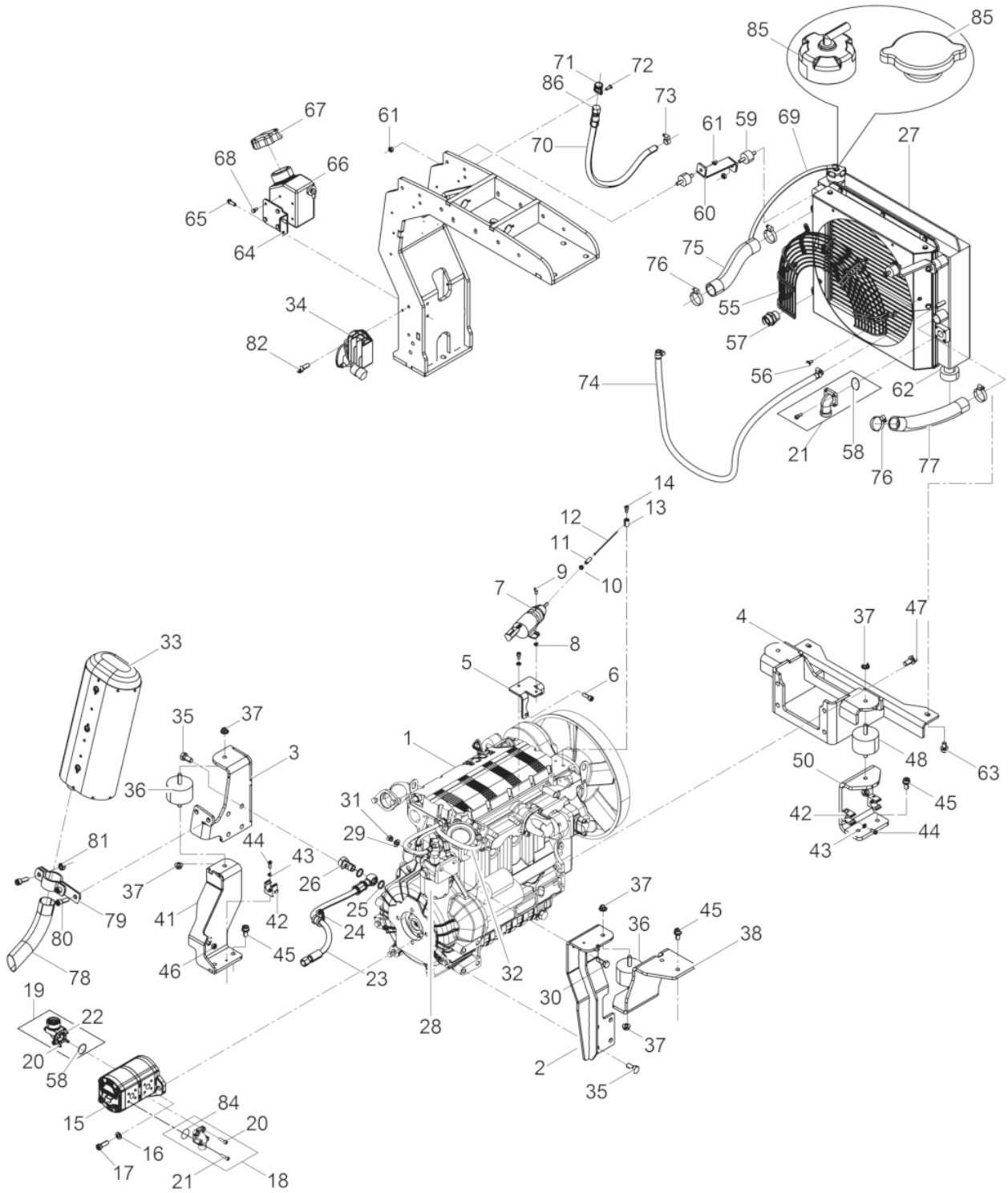

Ref. Pos.	Part No. Artikel Nr.	Qty. St.	Description Beschreibung	Descripción Description	Measurement/Abm.	Norm
					Torque/Drehm.	Sealant Schmierstoff
26	0207336	1	Hollow screw Hohlschraube	Tornillo hueco Boulon creux à filet femelle		
27	0211759	1	Radiator cpl. Kühler kpl.	Radiador cpl. Radiateur cpl.		
28	0215484	1	Fuel Filter Kraftstofffilter	Filtro de Combustible Filtre à Carburant		
28	5000210173	1	Filter-fuel cpl. Kraftstofffilter kpl.	Filtro de combustible cpl. re à carburant cpl.		
29	0010621	2	Washer Scheibe	Arandela Rondelle		
30	0011439	2	Hexagonal head cap screw Sechskantschraube	Tornillo hexagonal Vis à tête hexagonale	49Nm/36ft.lbs	
31	0010883	2	Hexagon nut Sechskantmutter	Tuerca hexagonal Écrou hexagonal		
32	0206595	1	Fuel hose Kraftstoffleitung	Manguera de combustible Tuyau à essence		
33	0206417	1	Muffler Schalldämpfer	Silenciador Silencieux		
34	5100006072	1	Governor Regler	Regulador Régulateur		
35	0013002	8	Hexagonal head cap screw Sechskantschraube	Tornillo hexagonal Vis à tête hexagonale	M12 x 25 86Nm/63ft.lbs	DIN933
36	5100000973	2	Shockmount Gummi-Metall-Puffer	Amortiguador Silentbloc		
37	0216640	8	Locknut Sicherungsmutter	Contratuerca Contre-écrou	60Nm/44ft.lbs	
38	0212633	1	Bracket-shockmount cpl. Pufferkonsole kpl.	Soporte de amortiguador cpl. Support de silentbloc cpl.		
40	0203234	1	Bolted connection Winkel-Flanschverschraubung	Atornilladura Fixation à bride angulaire		
41	5100031315	1	Bumper support cpl. Pufferaufnahme kpl.	Soporte de tope cpl. Fixation du tampon cpl.		
42	0210107	3	Clamp Schlauchklemme	Abrazadera Collier de serrage		
43	0010624	3	Flat washer Scheibe	Arandela Rondelle		
44	0211755	3	Screw Schraube	Tornillo Vis		
45	0210111	6	corrugated-head screw Sicherungsschraube	Tornillo Vis		
46	0010882	1	Hexagon nut Sechskantmutter	Tuerca hexagonal Écrou hexagonal		
47	0210165	4	corrugated-head screw Sicherungsschraube	Tornillo Vis		
48	5100000973	2	Shockmount Gummi-Metall-Puffer	Amortiguador Silentbloc		
50	0203943	2	Bumper support Pufferaufnahme	Soporte de tope Fixation du tampon		
55	0210117	1	Screen grid Schutzgitter	Rejilla de protección Grille de protection		

Diesel Engine cpl.
Dieselmotor kpl.
Motor Diesel cpl.
Moteur Diesel cpl.

DPU 130Le

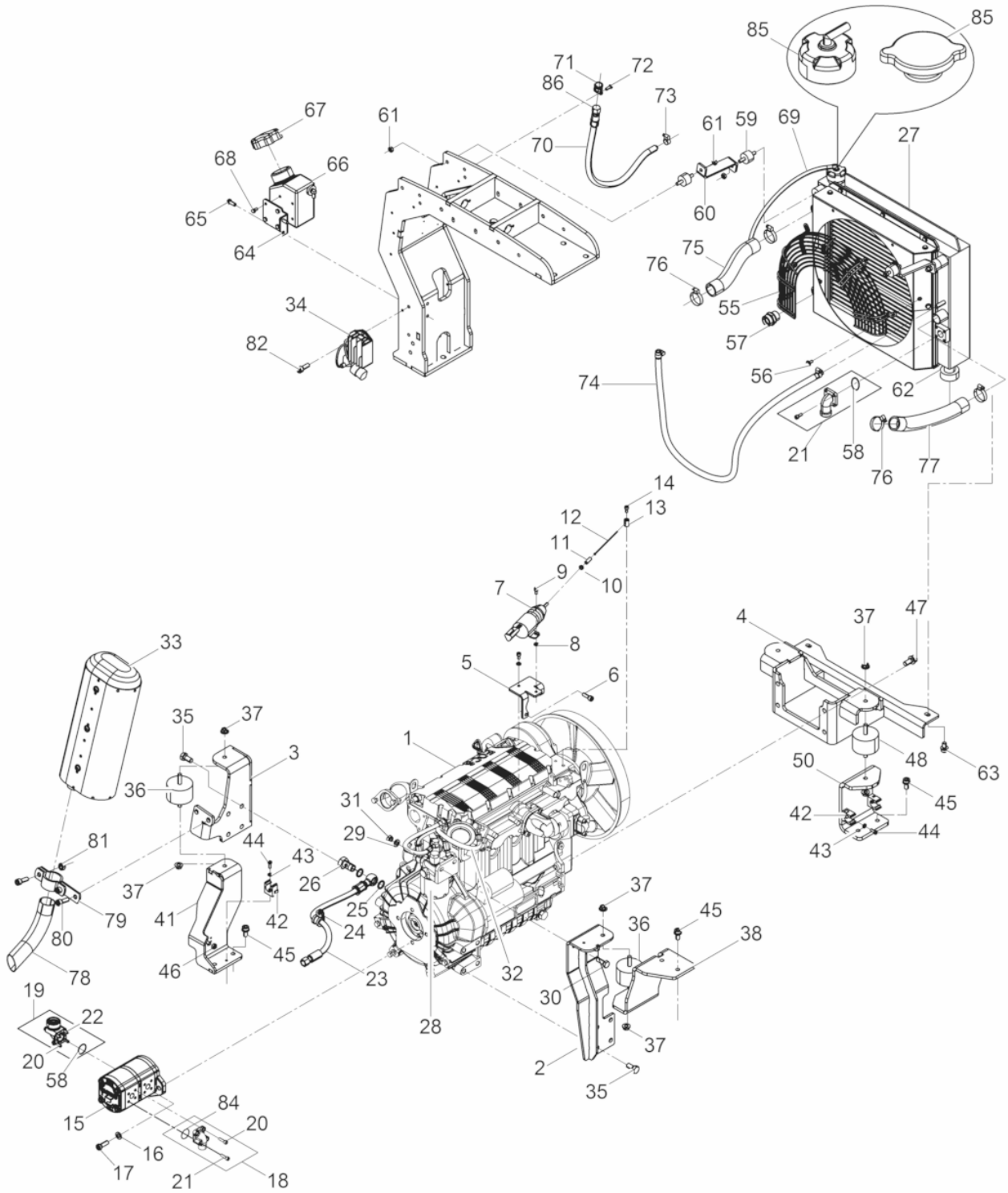

Ref. Pos.	Part No. Artikel Nr.	Qty. St.	Description Beschreibung	Descripción Description	Measurement./Abm.	Norm
					Torque/Drehm.	Sealant Schmierstoff
56	0210194	5	corrugated-head screw Sicherungsschraube	Tornillo Vis		
57	0046094	1	Screwed socket Einschraubstutzen	Empalme roscado Manchon visse	140Nm/103ft.lbs	DIN3901
58	0210115	3	O-Ring O-Ring	Anillo-O Joint torique		
59	0210118	4	Shockmount Gummi-Metall-Puffer	Tope caucho-metal Tampon metallique oscillant	30 x 20	
60	0208272	2	Bracket Halter	Soporte Équerre		
61	0010882	6	Hexagon nut Sechskantmutter	Tuerca hexagonal Écrou hexagonal		
62	0206517	2	Shockmount Gummi-Metall-Puffer	Tope caucho-metal Tampon metallique oscillant	50 x 20	
63	0212635	2	corrugated-head screw Sicherungsschraube	Tornillo Vis	M 10x 16	
64	0206569	1	Bracket Halter	Soporte Équerre		
65	0211756	4	Screw Schraube	Tornillo Vis	M 8x 20	DIN7500
66	0157209	1	Bottle-overflow Überlaufflasche	Botella de rebose Bouteille de trop-plein		
67	0157255	1	Cap Kappe	Tapa Couvercle		
68	0012357	4	Hexagonal head cap screw Sechskantschraube	Tornillo hexagonal Vis à tête hexagonale	M6 x 12 10Nm/7ft.lbs	DIN933
69	0207734	1	radiator hose Kühlerschlauch	Manguera de combustible Tuyau à essence		
70	0211747	1	Hose cpl. Schlauch kpl.	Manguera cpl. Tuyau cpl.		
71	0017123	1	Pipe clamp Rohrschelle	Abrazadera Collier pour tuyau		
72	0211755	1	Screw Schraube	Tornillo Vis		
73	0016837	3	Clamp Schneckenengewindeschelle	Abrazadera Agrafe	12-20	
74	0207735	1	Hose pipe Schlauchleitung	Conducto flexible Conduite flexible		
75	0208283	1	Water Hose Wasserschlauch	Manguera de agua Tuyau d'eau		
76	2004724	4	Worm drive house clip Schneckenengewindeschelle	Abrazadera con sinfín Collier de serrage		
77	0208284	1	Water Hose Wasserschlauch	Manguera de agua Tuyau d'eau		
78	0206418	1	Exhaust-Pipe End Auspuffendrohr	Extremo de la Extractor-Pipa Extrémité de Échappement-Pipe		
79	0209113	1	Clamp Rohrschelle	Abrazadera Agrafe	ø43	DIN3567
80	0011534	3	Cheese head screw Zylinderschraube	Tornillo cilíndrico Vis à tête cylindrique	M10 x 30 49Nm/36ft.lbs	ISO4762

Diesel Engine cpl.
Dieselmotor kpl.
Motor Diesel cpl.
Moteur Diesel cpl.

DPU 130Le

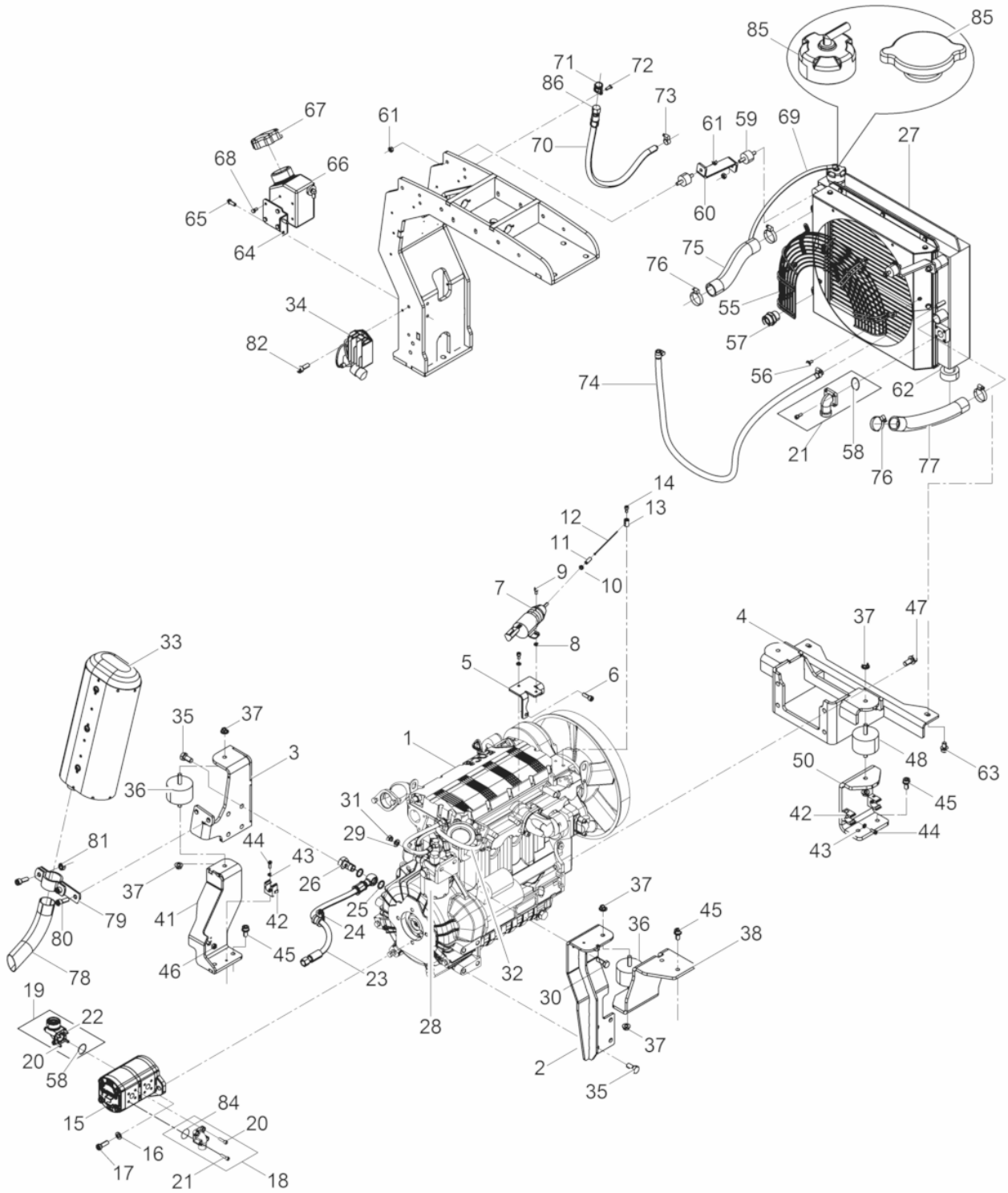

Ref. Pos.	Part No. Artikel Nr.	Qty. St.	Description Beschreibung	Descripción Description	Measurement./Abm.	Norm
					Torque/Drehm.	Sealant Schmierstoff
81	0017313	1	Hexagon nut Sechskantmutter	Tuerca hexagonal Écrou hexagonal		
82	0211756	2	Screw Schraube	Tornillo Vis	M 8x 20	DIN7500
84	0210116	1	O-Ring O-Ring	Anillo-O Joint torique		
85	5100011421	1	Cover (bayonet lock) Deckel (Bajonettverschluss)	Tapa (cierre de bayoneta) Couvercle (fermeture à baïonne)		
85	0211757	1	Cover Deckel	Cubierta Couvercle		
86	0211773	1	Nose cap Verschlusskappe	Tapa de cierre Chape de fermeture		

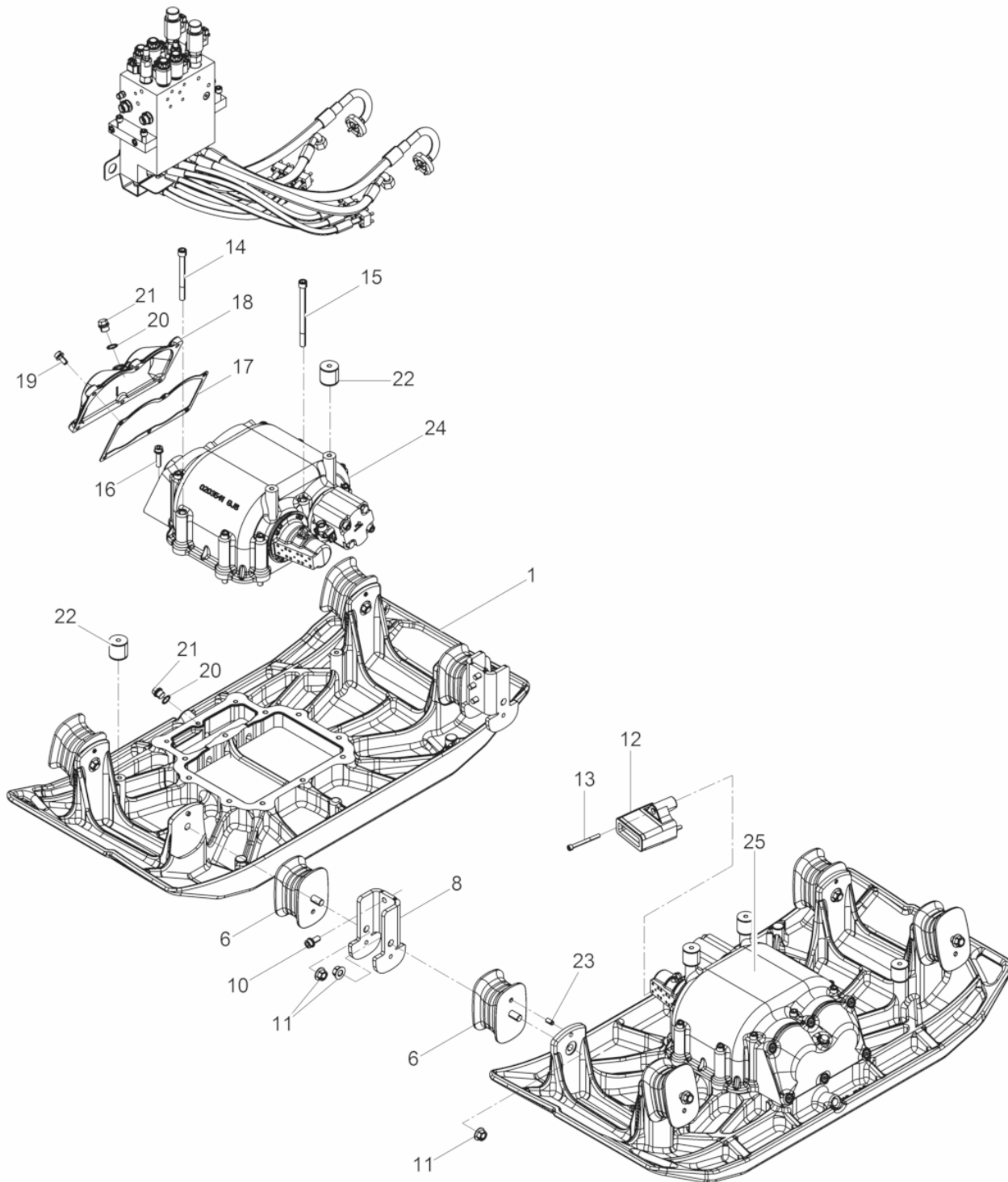

Ref. Pos.	Part No. Artikel Nr.	Qty. St.	Description Beschreibung	Descripción Description	Measurement./Abm.	Norm
					Torque/Drehm.	Sealant Schmierstoff
1	0204824	2	Baseplate Untermasse	Masa inferior Masse inferieure		
6	0216648	8	Silent block Gummipuffer	Bloque silente Silentbloc		
8	0206496	2	Bumper support Pufferaufnahme	Soporte de tope Fixation du tampon		
10	0210165	6	corrugated-head screw Sicherungsschraube	Tornillo Vis		
11	0212628	16	Locknut Sicherungsmutter	Contratuercas Contre-écrou		
12	0216591	2	Protection Schutz	Protección Protection		
13	0012379	4	Cheese head screw Zylinderschraube	Tornillo cilíndrico Vis à tête cylindrique	M8 x 80 25Nm/18ft.lbs	ISO4762
14	0094518	12	Cheese head screw Zylinderschraube	Tornillo cilíndrico Vis à tête cylindrique	M12 x 120 120Nm/89ft.lbs	ISO4762
15	0204133	8	Cheese head screw Zylinderschraube	Tornillo cilíndrico Vis à tête cylindrique	M12x160	ISO4762
16	0209159	6	corrugated-head screw Sicherungsschraube	Tornillo Vis	M 10x 40	
17	0206453	2	Gasket Dichtung	Junta de estanqueidad Garniture		
18	0206452	2	Cover Deckel	Cubierta Couvercle		
19	0210111	12	corrugated-head screw Sicherungsschraube	Tornillo Vis		
20	0019156	4	Gasket Dichtring	Anillo de junta Bague d'étanchéité		
21	0068222	4	Plug (threaded) Verschlußschraube	Tapón roscado Bouchon		
22	0216644	8	Shockmount Puffer	Amortiguador Silentbloc		
23	0203227	8	Roll pin Spannstift	Pasador Goupille de tension		
24	5100011160	1	Exciter cpl. right Erreger kpl. rechts	Excitador cpl. derecha Excitateur cpl. droite		
25	5100011161	1	Exciter cpl. left Erreger kpl. links	Excitador cpl. izquierda Excitateur cpl. gauche		

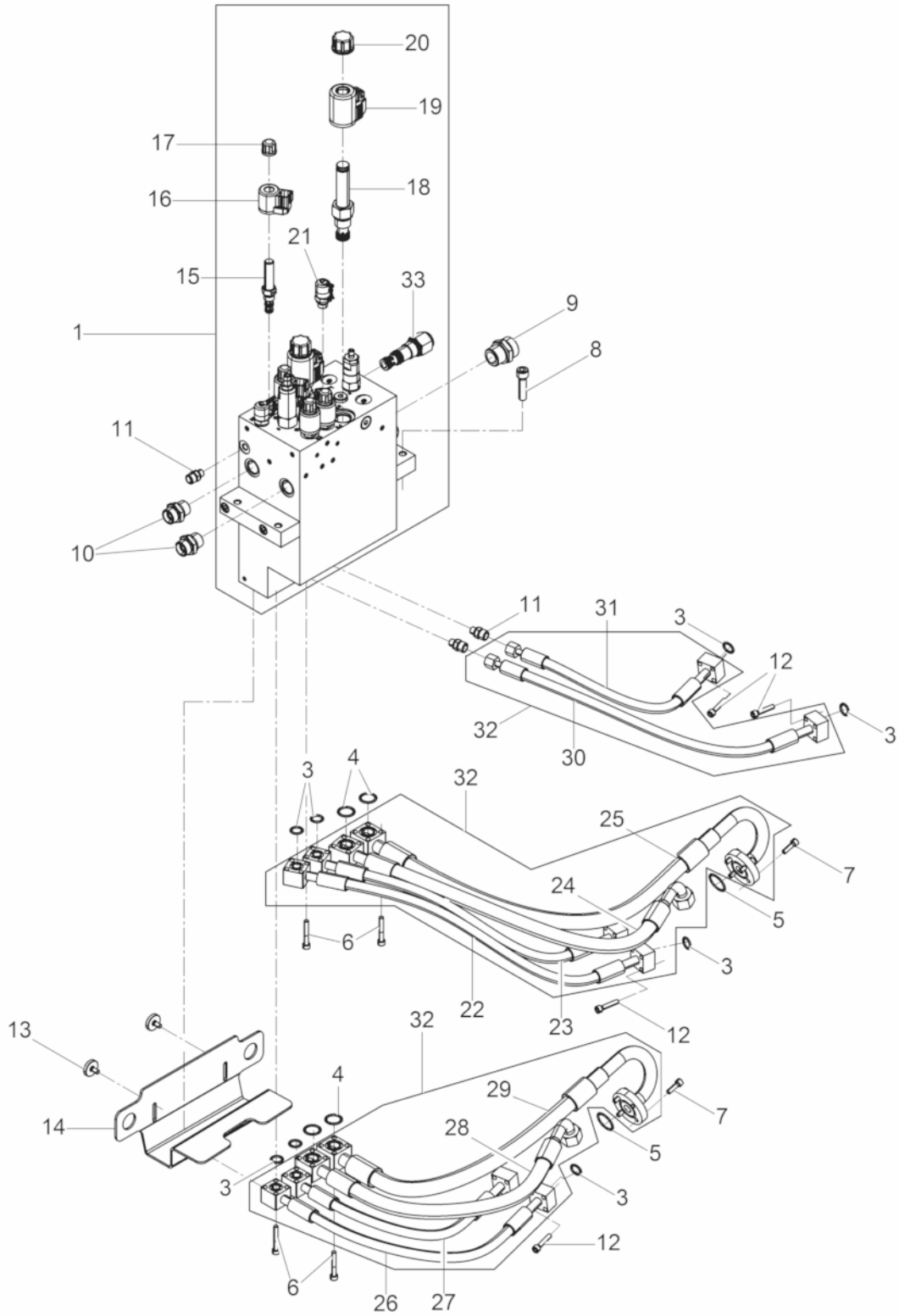

Ref. Pos.	Part No. Artikel Nr.	Qty. St.	Description Beschreibung	Descripción Description	Measurement./Abm.	Norm
					Torque/Drehm.	Sealant Schmierstoff
1	5100031274	1	Block-Hydraulic Hydraulikblock	Bloque Hidráulico Bloc Hydraulique		
3	0017549	10	O-Ring O-Ring	Anillo-O Joint torique	14,00 x 2,50	
4	0210116	4	O-Ring O-Ring	Anillo-O Joint torique		
5	0210115	2	O-Ring O-Ring	Anillo-O Joint torique		
6	0011547	32	Cheese head screw Zylinderschraube	Tornillo cilíndrico Vis à tête cylindrique	10Nm/7ft.lbs	
7	0011551	8	Cheese head screw Zylinderschraube	Tornillo cilíndrico Vis à tête cylindrique	10Nm/7ft.lbs	
8	0011532	4	Cheese head screw Zylinderschraube	Tornillo cilíndrico Vis à tête cylindrique	M10 x 40 49Nm/36ft.lbs	ISO4762
9	0046094	1	Screwed socket Einschraubstutzen	Empalme roscado Manchon visse		DIN3901
10	0046093	2	Screwed socket Einschraubstutzen	Empalme roscado Manchon visse		DIN3901
11	0220044	3	Screwed socket Einschraubstutzen	Empalme roscado Manchon visse	L 8 B-M10x1	DIN3901
12	0011549	24	Cheese head screw Zylinderschraube	Tornillo cilíndrico Vis à tête cylindrique	M6 x 30 10Nm/7ft.lbs	ISO4762
13	0220184	2	Thumb screw Rändelschraube	Cabeza moleteada Vis	M 6x12	DIN653
14	0220091	1	Protective cloth Schutzlappen	Trapo de protección Protection		
15	5100032214	4	Control Valve Steuerventil	Válvula distribuidora Soupape de direction		
16	5100032215	4	Solenoid Magnetspule	Solenoido Solénoide		
17	5100032216	4	Valve cap Ventilkappe	Casquete de válvula Joint de soupape		
18	5100032217	2	Valve Throttle Stromdrosselventil	Válvula Estrangulador Soupape Etranglement		
19	5100032218	2	Solenoid Magnetspule	Solenoido Solénoide		
20	0220194	2	Valve cap Ventilkappe	Casquete de válvula Joint de soupape		
21	0220198	2	Test port Messanschluss	Conexión de medición Raccordement		
22	0206458	1	Hose pipe Schlauchleitung	Conducto flexible Conduite flexible		
23	0206459	1	Hose pipe Schlauchleitung	Conducto flexible Conduite flexible		
24	0206460	1	Hose pipe Schlauchleitung	Conducto flexible Conduite flexible		
25	0206461	1	Hose pipe Schlauchleitung	Conducto flexible Conduite flexible		
26	0206462	1	Hose pipe Schlauchleitung	Conducto flexible Conduite flexible		

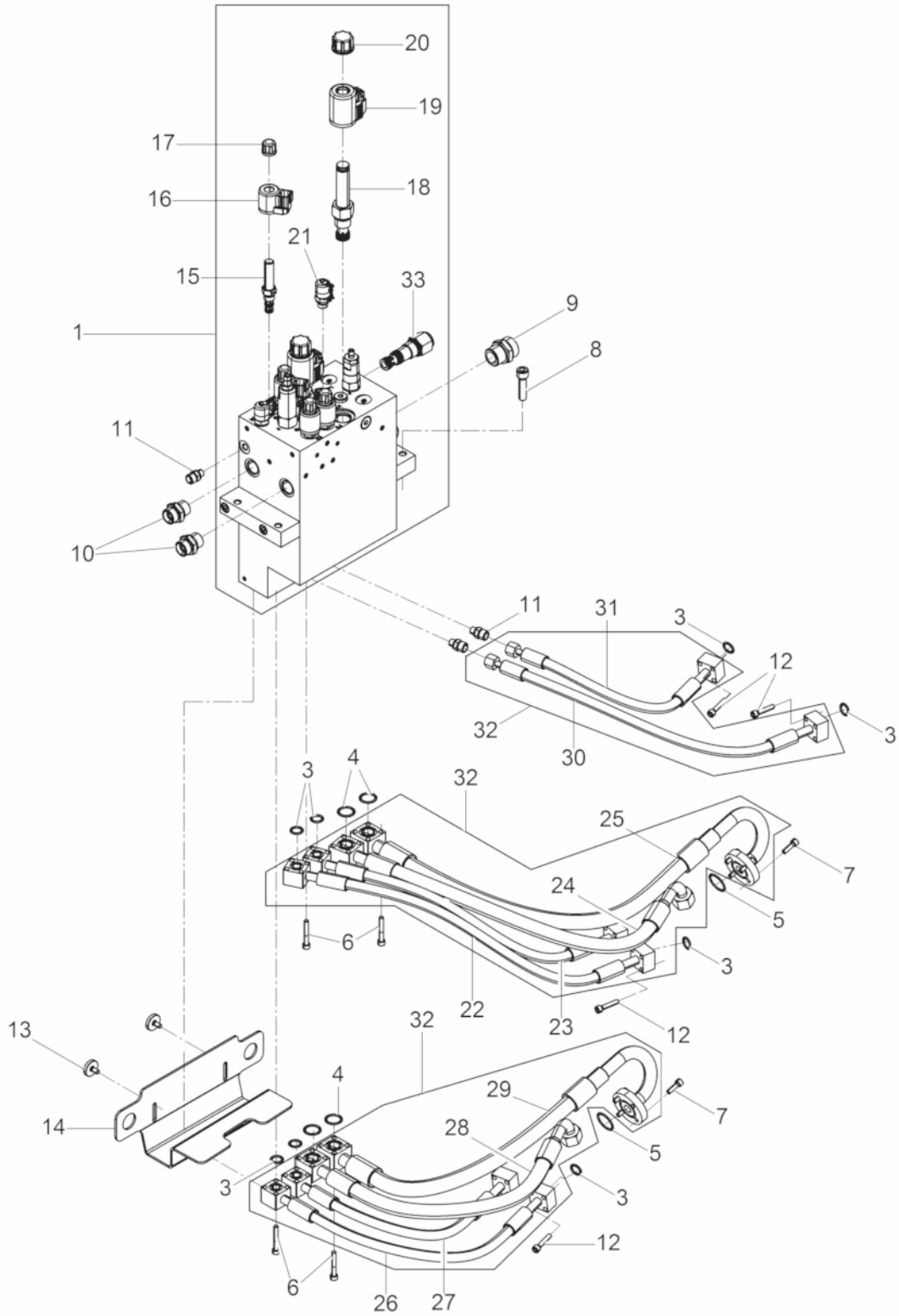

Ref. Pos.	Part No. Artikel Nr.	Qty. St.	Description Beschreibung	Descripción Description	Measurement./Abm.	Norm
					Torque/Drehm.	Sealant Schmierstoff
27	0206463	1	Hose pipe Schlauchleitung	Conducto flexible Conduite flexible		
28	0206464	1	Hose pipe Schlauchleitung	Conducto flexible Conduite flexible		
29	0206465	1	Hose pipe Schlauchleitung	Conducto flexible Conduite flexible		
30	0208237	1	Breather tube Entlüftungsleitung	Línea de purgado Tuyau d'évacuation purge		
31	0208238	1	Breather tube Entlüftungsleitung	Línea de purgado Tuyau d'évacuation purge		
32	0211785	1	Hydraulic hose System Hydraulikverschlauchung	Manguera hidráulica Sistema Tuyau hydraulique Système		
33	5100032219	2	pressure maintenance valve Druckwaage	regulador de presión compensateur de pression		

Exciter cpl. left
Erreger kpl. links

DPU 130Le

Excitador cpl. izquierda
Excitateur cpl. gauche

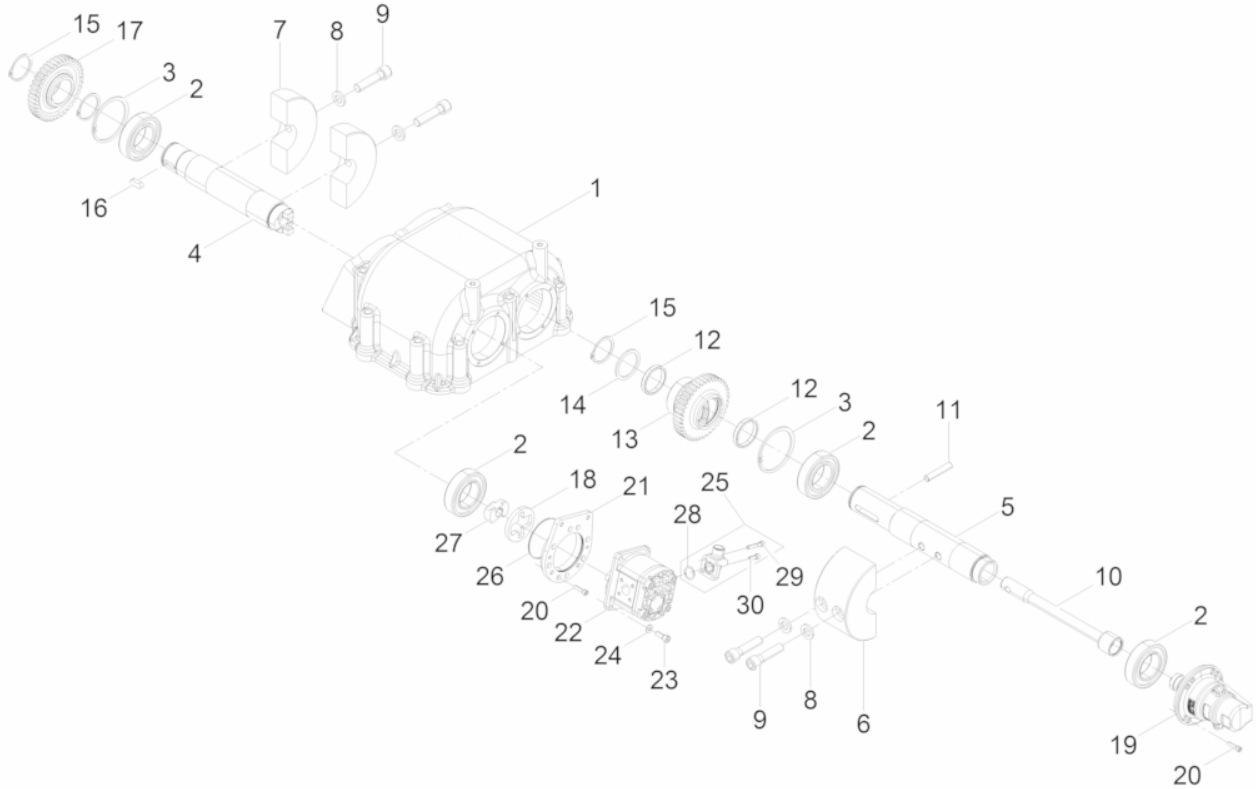

Ref. Pos.	Part No. Artikel Nr.	Qty. St.	Description Beschreibung	Descripción Description	Measurem./Abm.	Norm
					Torque/Drehm.	Sealant Schmierstoff
1	5100011031	1	Exciter housing Erregergehäuse	Carcasa del excitador Carter excitateur		
2	0103469	4	Cylindrical roller bearing Zylinderrollenlager	Rodamiento cilíndricos Roulement à rouleaux		
3	2007057	2	Retaining ring Sicherungsring	Anillo de retención Bague d'arrêt	90 x 3	DIN472
4	5100003934	1	Driving shaft Antriebswelle	Albero comando Arbre d'entraînement		
5	0204522	1	Shaft Verstellwelle	Árbol Arbre		
6	0204553	1	Eccentric weight Unwucht	Masa excéntrica Balourd		
7	0204554	2	Eccentric weight Unwucht	Masa excéntrica Balourd		
8	0021988	4	Lock washer Sicherungsscheibe	Arandela de seguridad Rondelle d'arrêt	HS16	
9	0204132	4	Cheese head screw Zylinderschraube	Tornillo cilíndrico Vis à tête cylindrique	M16x 65	ISO4762
10	0204525	1	Piston rod Kolbenstange	Biela de pistón Tige de piston		
11	0204527	1	Tripping pin Schaltstift	Espiga de mando Broche de manoeuvre		
12	0206436	2	Bearing bush Lagerbuchse	Casquillo del cojinete Bôte de roulement		
13	0204130	1	Adjusting sleeve left Verstellhülse links	Husillo de regulación izquierda Douille de réglage gauche		
14	2006977	1	Supporting Washer Stützscheibe	Arandela de Soporte Disque D'Appui	S 50x 62	DIN988
15	2006113	3	Retaining ring Sicherungsring	Anillo de retención Bague d'arrêt		
16	2001399	1	Fitting key Passfeder	Chaveta Clavette	A10 x 8 x 28	DIN6885
17	0039116	1	Gear wheel Zahnrad	Engranaje Roue dentée		
18	5100003535	1	Disc Kreuzscheibe	Disco Disque		
19	0212595	1	Adjustment cylinder cpl. Verstellzylinder kpl	Cilindro del ajuste cpl. Cylindre d'ajustement cpl.		
20	0220001	8	Cheese head screw Zylinderschraube	Tornillo cilíndrico Vis à tête cylindrique		
21	5100003678	1	Flange Flansch	Brida Bride		
22	5100004199	1	Gear motor left Zahnradmotor links	Motor hidráulico de engranajes Motor roue dentée		
23	0012629	4	Cheese head screw Zylinderschraube	Tornillo cilíndrico Vis à tête cylindrique		
24	0010622	4	Flat washer Scheibe	Arandela Rondelle		
25	5100046101	1				

Exciter cpl. left
Erreger kpl. links

DPU 130Le

Excitador cpl. izquierda
Excitateur cpl. gauche

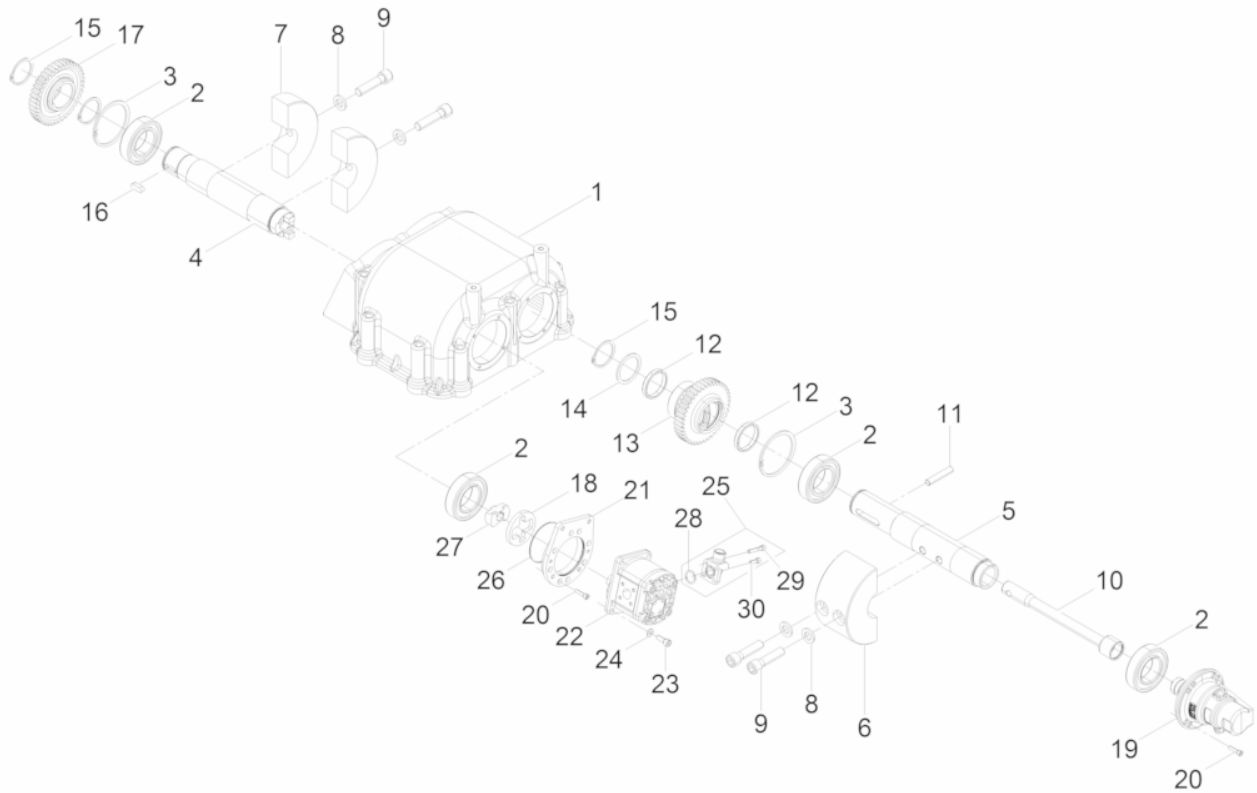

Ref. Pos.	Part No. Artikel Nr.	Qty. St.	Description Beschreibung	Descripción Description	Measurement/Abm.	Norm
					Torque/Drehm.	Sealant Schmierstoff
26	5100004118	1	O-ring O-Ring	Anillo-O Bague-O		
27	5100003696	1	Carrier Mitnehmer	Arrastrador Levier d'entrainement		
28	0210116	1	O-Ring O-Ring	Anillo-O Joint torique		
29	0011548	2	Cheese head screw Zylinderschraube	Tornillo cilíndrico Vis à tête cylindrique		
30	0011552	2	Cheese head screw Zylinderschraube	Tornillo cilíndrico Vis à tête cylindrique	M6 x 18 10Nm/7ft.lbs	ISO4762

Exciter cpl. right
Erreger kpl. rechts

DPU 130Le

Excitador cpl. derecho
Excitateur cpl. droite

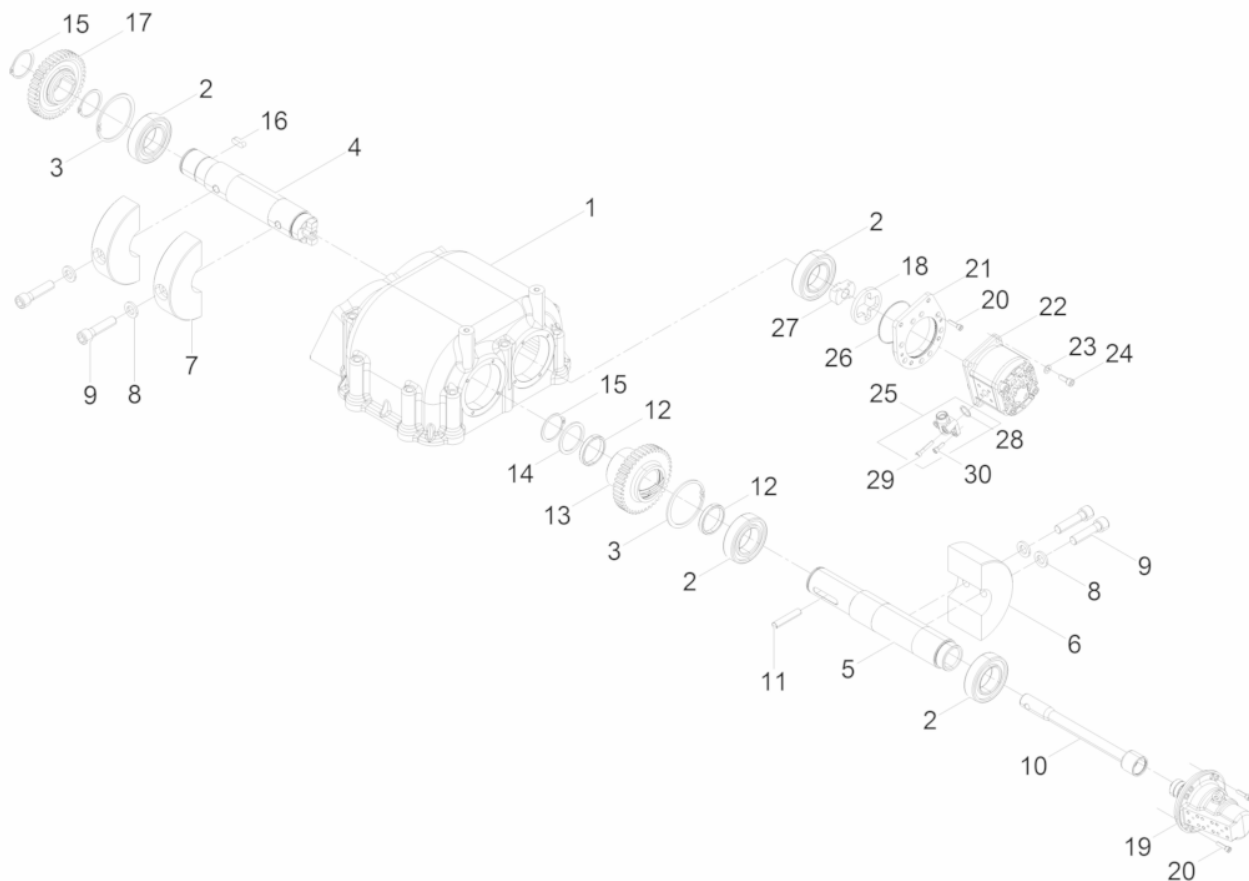

Ref. Pos.	Part No. Artikel Nr.	Qty. St.	Description Beschreibung	Descripción Description	Measurem./Abm.	Norm
					Torque/Drehm.	Sealant Schmierstoff
1	5100011031	1	Exciter housing Erregergehäuse	Carcasa del excitador Carter excitateur		
2	0103469	4	Cylindrical roller bearing Zylinderrollenlager	Rodamiento cilíndricos Roulement à rouleaux		
3	2007057	2	Retaining ring Sicherungsring	Anillo de retención Bague d'arrêt	90 x 3	DIN472
4	5100003934	1	Driving shaft Antriebswelle	Albero comando Arbre d'entraînement		
5	0204522	1	Shaft Verstellwelle	Árbol Arbre		
6	0204553	1	Eccentric weight Unwucht	Masa excéntrica Balourd		
7	0204554	2	Eccentric weight Unwucht	Masa excéntrica Balourd		
8	0021988	4	Lock washer Sicherungsscheibe	Arandela de seguridad Rondelle d'arrêt	HS16	
9	0204132	4	Cheese head screw Zylinderschraube	Tornillo cilíndrico Vis à tête cylindrique	M16x 65	ISO4762
10	0204525	1	Piston rod Kolbenstange	Biela de pistón Tige de piston		
11	0204527	1	Tripping pin Schaltstift	Espiga de mando Broche de manoeuvre		
12	0206436	2	Bearing bush Lagerbuchse	Casquillo del cojinete Bôte de roulement		
13	0204128	1	Adjusting sleeve right Verstellhülse rechts	Husillo de regulación derecha Douille de réglage droite		
14	2006977	1	Supporting Washer Stützscheibe	Arandela de Soporte Disque D'Appui	S 50x 62	DIN988
15	2006113	3	Retaining ring Sicherungsring	Anillo de retención Bague d'arrêt		
16	2001399	1	Fitting key Passfeder	Chaveta Clavette	A10 x 8 x 28	DIN6885
17	0039116	1	Gear wheel Zahnrad	Engranaje Roue dentée		
18	5100003535	1	Disc Kreuzscheibe	Disco Disque		
19	0212595	1	Adjustment cylinder cpl. Verstellzylinder kpl	Cilindro del ajuste cpl. Cylindre d'ajustement cpl.		
20	0220001	8	Cheese head screw Zylinderschraube	Tornillo cilíndrico Vis à tête cylindrique		
21	5100003678	1	Flange Flansch	Brida Bride		
22	5100004198	1	Gear motor right Zahnradmotor rechts	Motor hidráulico de engranaje Motor roue dentée		
23	0012629	4	Cheese head screw Zylinderschraube	Tornillo cilíndrico Vis à tête cylindrique		
24	0010622	4	Flat washer Scheibe	Arandela Rondelle		
25	5100046101	1				

Exciter cpl. right
Erreger kpl. rechts

DPU 130Le

Excitador cpl. derecho
Excitateur cpl. droite

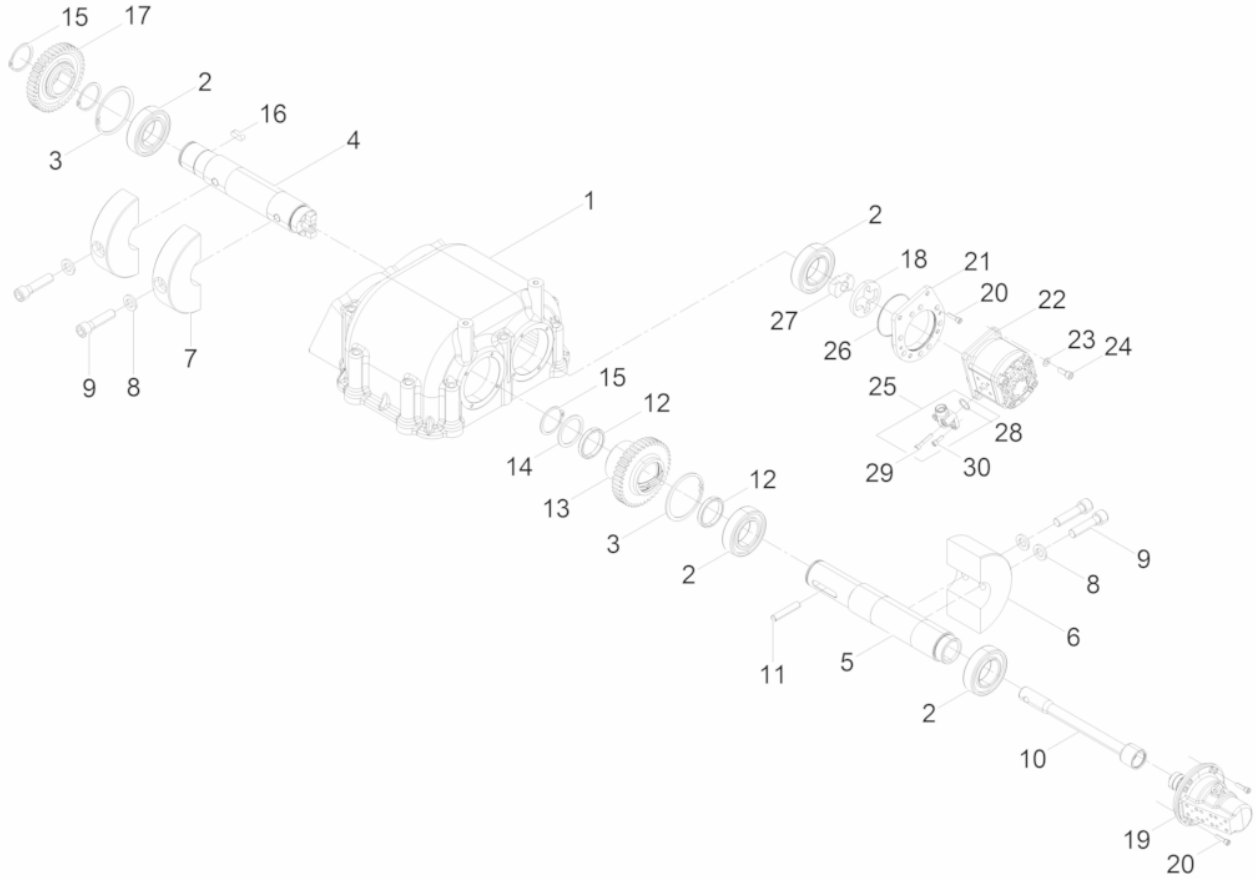

Ref. Pos.	Part No. Artikel Nr.	Qty. St.	Description Beschreibung	Descripción Description	Measurement/Abm.	Norm
					Torque/Drehm.	Sealant Schmierstoff
26	5100004118	1	O-ring O-Ring	Anillo-O Bague-O		
27	5100003696	1	Carrier Mitnehmer	Arrastrador Levier d'entrainement		
28	0210116	1	O-Ring O-Ring	Anillo-O Joint torique		
29	0011548	2	Cheese head screw Zylinderschraube	Tornillo cilíndrico Vis à tête cylindrique		
30	0011552	2	Cheese head screw Zylinderschraube	Tornillo cilíndrico Vis à tête cylindrique	M6 x 18 10Nm/7ft.lbs	ISO4762

Adjustment cylinder
Verstellzylinder
Cilindro del ajuste
Cylindre d'ajustement

DPU 130Le

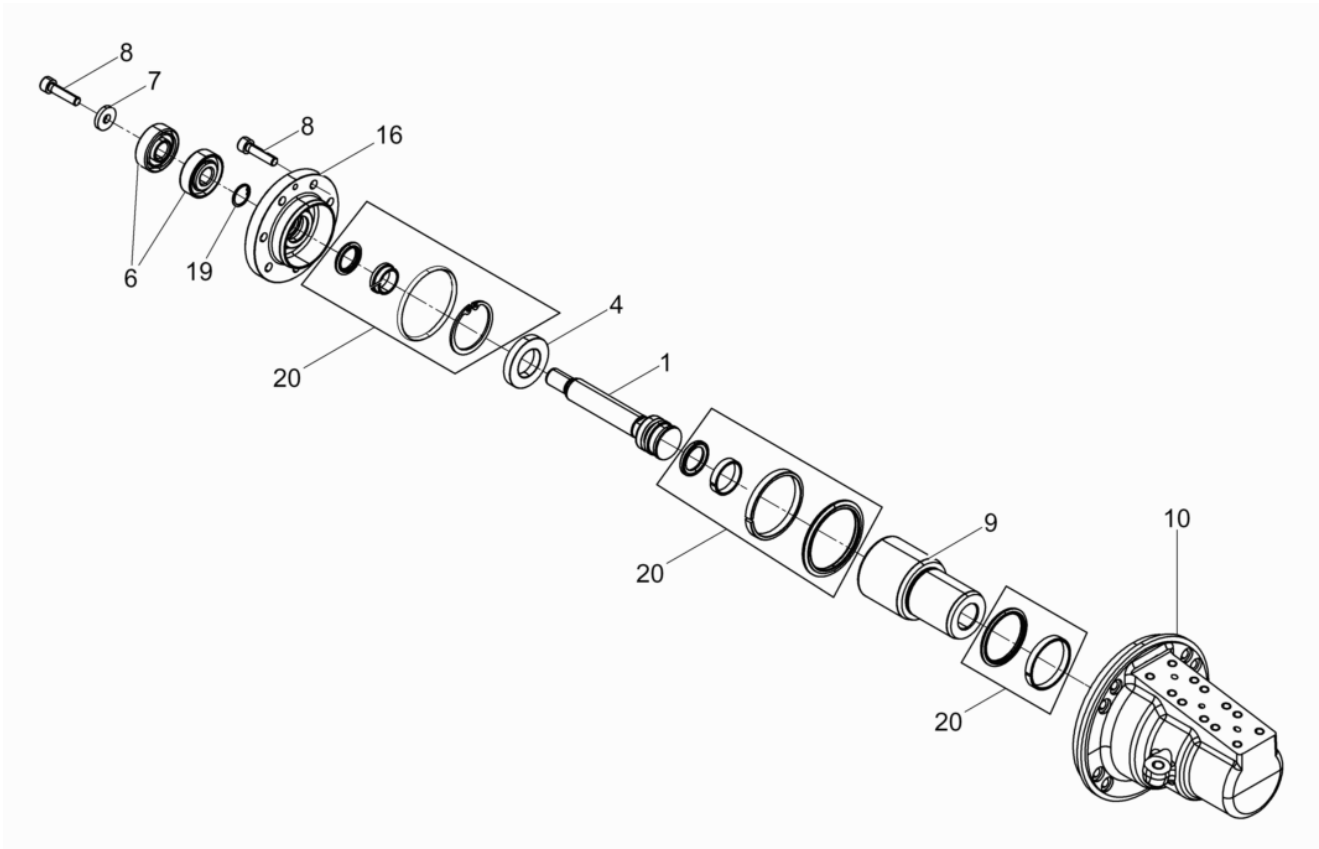

Ref. Pos.	Part No. Artikel Nr.	Qty. St.	Description Beschreibung	Descripción Description	Measurement./Abm.	Norm
					Torque/Drehm.	Sealant Schmierstoff
1	0204538	1	Piston Kolben	Pistón Piston		
4	0212159	1	Washer Scheibe	Disco Rondelle		
6	0044950	2	Inclined ball bearing Schrägkugellager	Rodamiento de bolas oblicuo Roulement à billes oblique		
7	0124717	1	Washer Scheibe	Arandela Rondelle		
8	0220001	8	Cheese head screw Zylinderschraube	Tornillo cilíndrico Vis à tête cylindrique		
9	0212158	1	stepped piston Stufenkolben	Pistón Piston		
10	0212157	1	Adjustment cylinder Verstellzylinder	Cilindro del ajuste Cylindre d'ajustement		
15	2004297	1	O-ring O-Ring	Anillo-O Bague-O	50 x 3	
16	0212594	1	Cover Deckel	Cubierta Couvercle		
19	2001939	1	Retaining ring Sicherungsring	Anillo de retención Bague d'arrêt	32 x 1,2	DIN472
20	0220213	1	Set-gasket Adjustment cylinder Dichtungssatz Verstellzylinder	Juego de juntas Cilindro del ajuste Jeu de joints Cylindre		

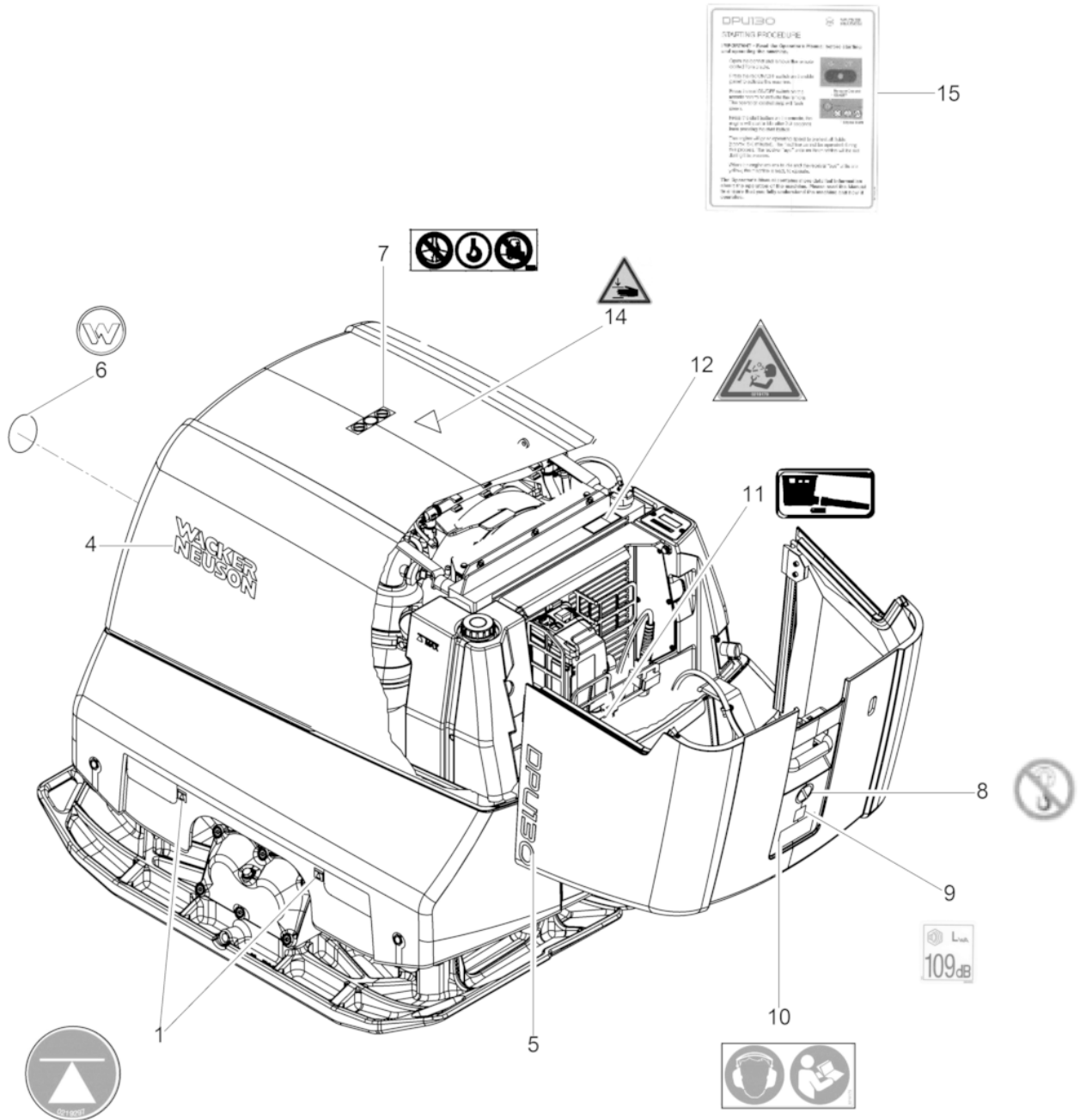

Ref. Pos.	Part No. Artikel Nr.	Qty. St.	Description Beschreibung	Descripción Description	Measurement./Abm.	Norm
					Torque/Drehm.	Sealant Schmierstoff
1	0219297	2	Labels Aufkleber	Calcomanías Autocollants		
4	0222103	2	Label logo Aufkleber Logo	Calcomanía Insignia Autocollant Logo	80 mm	
5	0216634	2	Type Label Aufkleber-Typ	Tipo etiqueta autoadhesiva Autocollant de type		
6	0222086	1	Label Symbol Aufkleber Symbol	Calcomanía Símbolo Autocollant Symbole		
7	0216633	1	Instruction Label Aufkleber-Hinweis	Calcomanía-Indicación Autocollant avec Indication		
8	0220000	1	Instruction Label Aufkleber-Warnhinweis	Calcomanía-Indicación Autocollant avec Indication		
9	0064925	1	Decal-Sound Power Level Aufkleber-Schalleistungspegel	Etiqueta autoadhesiva-nivel de potencia acúèèstica Autocollante-niveau sonore		
10	0219175	1	Labels Aufkleber	Calcomanías Autocollants		
11	0216635	1	Labels Aufkleber	Calcomanías Autocollants		
12	0219179	1	Labels Aufkleber	Calcomanías Autocollants		
14	0207747	1	Danger label Aufkleber Quetschgefahr	Calcomanía de peligro Autocollant de danger		
15	5100011054	1	Labels Aufkleber	Calcomanías Autocollants		

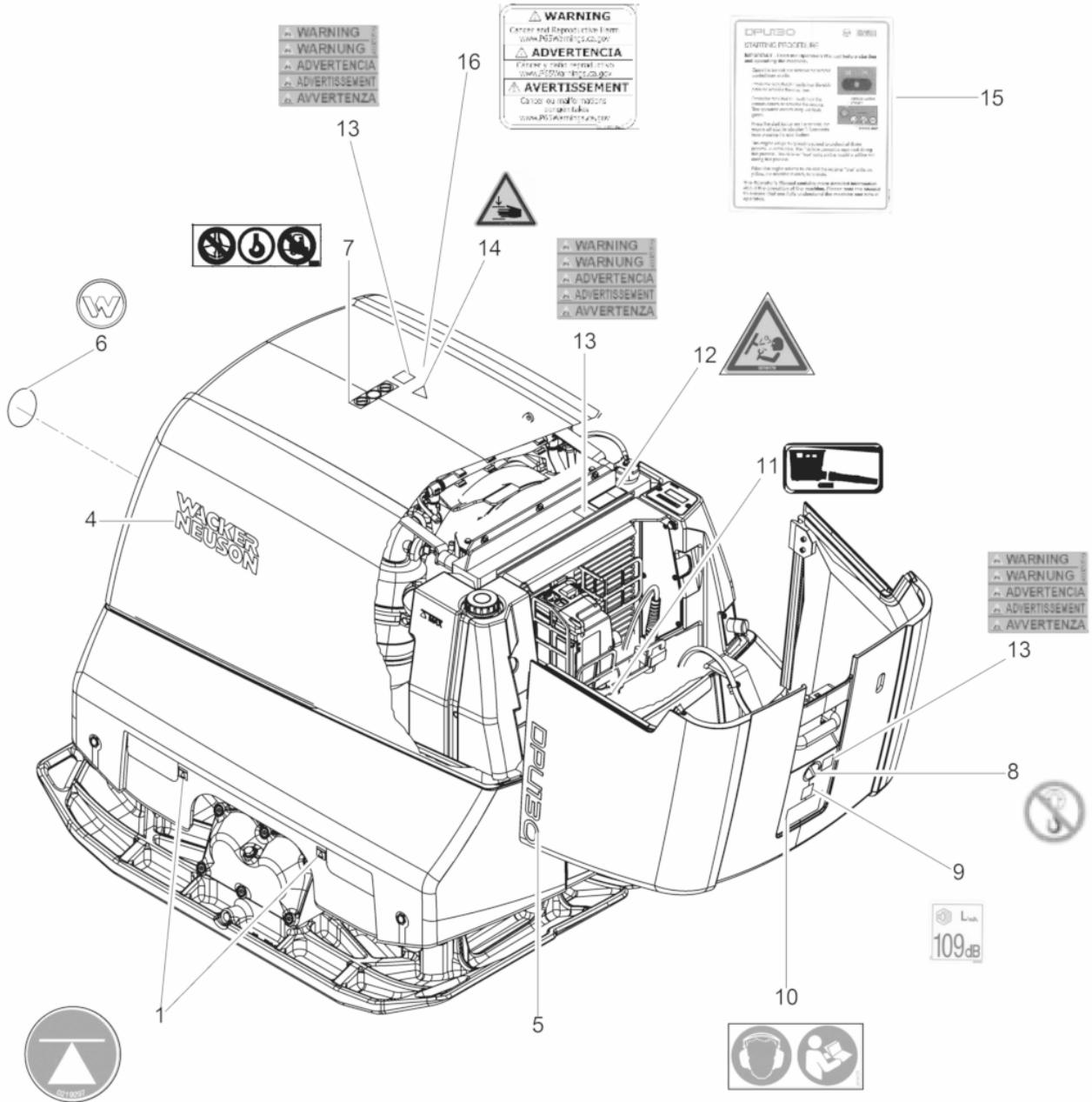

Ref. Pos.	Part No. Artikel Nr.	Qty. St.	Description Beschreibung	Descripción Description	Measurem./Abm.	Norm
					Torque/Drehm.	Sealant Schmierstoff
1	0219297	2	Labels Aufkleber	Calcomanías Autocollants		
4	0222103	2	Label logo Aufkleber Logo	Calcomanía Insignia Autocollant Logo	80 mm	
5	0216634	2	Type Label Aufkleber-Typ	Tipo etiqueta autoadhesiva Autocollant de type		
6	0222086	1	Label Symbol Aufkleber Symbol	Calcomanía Símbolo Autocollant Symbole		
7	0216633	1	Instruction Label Aufkleber-Hinweis	Calcomanía-Indicación Autocollant avec Indication		
8	0220000	1	Instruction Label Aufkleber-Warnhinweis	Calcomanía-Indicación Autocollant avec Indication		
9	0064925	1	Decal-Sound Power Level Aufkleber-Schalleistungspegel	Etiqueta autoadhesiva-nivel de potencia acúèèstica Autocollante-niveau sonore		
10	0219175	1	Labels Aufkleber	Calcomanías Autocollants		
11	0216635	1	Labels Aufkleber	Calcomanías Autocollants		
12	0219179	1	Labels Aufkleber	Calcomanías Autocollants		
13	0219176	3	Labels Aufkleber	Calcomanías Autocollants		
14	0207747	1	Danger label Aufkleber Quetschgefahr	Calcomanía de peligro Autocollant de danger		
15	5100011054	1	Labels Aufkleber	Calcomanías Autocollants		
16	5100045462	1	Label Label	Label Label		



**WACKER
NEUSON**

**Engine
Motor
Motor
Moteur**

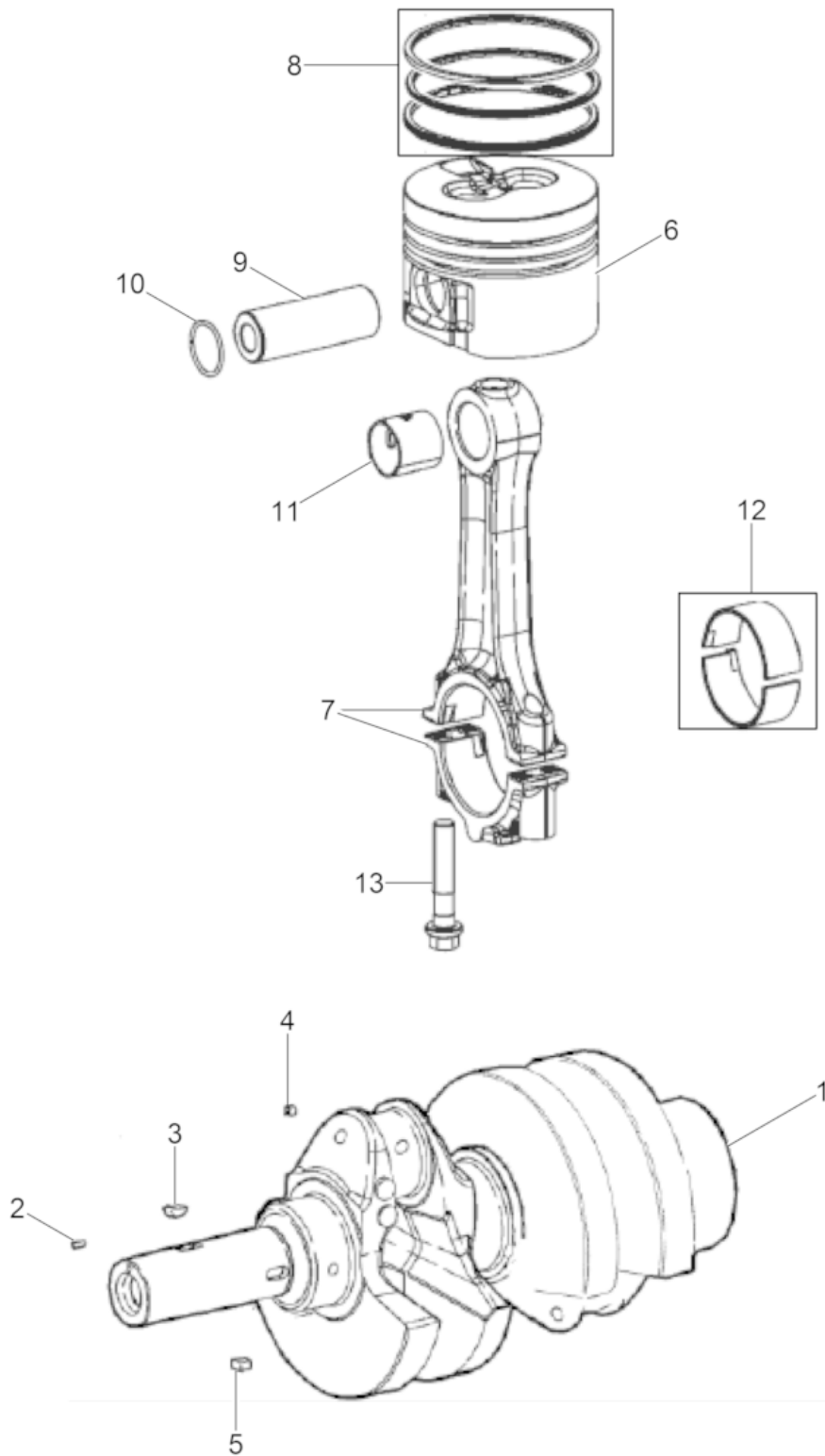

Ref. Pos.	Part No. Artikel Nr.	Qty. St.	Description Beschreibung	Descripción Description	Measur./Abm.	Norm
					Torque/Drehm.	Sealant Schmierstoff
1	0211362	1	Crankshaft cpl. Kurbelwelle kpl.	Cigüeñal cpl. Vilebrequin cpl.		
2	0159357	1	Pin Stift	Espiga Goupille		
3	0159260	1	Woodruff key Woodruffkeil	Chaveta Woodruff Clavette Woodruff		
4	0159454	4	Plug (threaded) Schraubverschluß	Tapón roscado Bouchon		
5	0160195	1	Key Keil	Llave Clé	12	
6	0160375	4	Set Of Piston Kolbensatz	Juego de Pistón Jeu de Piston		
6	0160376	4	Set Of Piston Kolbensatz	Juego de Pistón Jeu de Piston		
6	0160377	4	Set Of Piston Kolbensatz	Juego de Pistón Jeu de Piston		
7	0160367	4	Connecting rod Pleuel	Biela Bielle		
8	0160383	1	Piston Ring Set Kolbenringsatz	Juego de cubo levantador Jeu de moyeu de levage		
8	0160384	2	Kit-lift ring Ringsatz	Juego de cubo levantador Jeu de moyeu de levage		
8	0160385	2	Kit-lift ring Ringsatz	Juego de cubo levantador Jeu de moyeu de levage		
9	0215523	4	Piston pin Kolbenbolzen	Perno de pistón Axe de piston		
10	0215477	8	Retaining ring Sicherungsring	Anillo de retención Bague d'arrêt		
11	0160368	2	Bushing Buchse	Buje Douille		
12	0155689	2	Bearing Lagerschalen	Rodamiento Roulement		
12	0155690	2	Bearing Pleuellagerangen	Rodamiento Roulement		
12	0155691	2	Bearing Pleuellagerangen	Rodamiento Roulement		
13	0084175	4	Screw Schraube	Tornillo Vis		

Crankcase cpl.
Kurbelgehäuse kpl.
Cárter cpl.
Carter cpl.

DPU 130Le

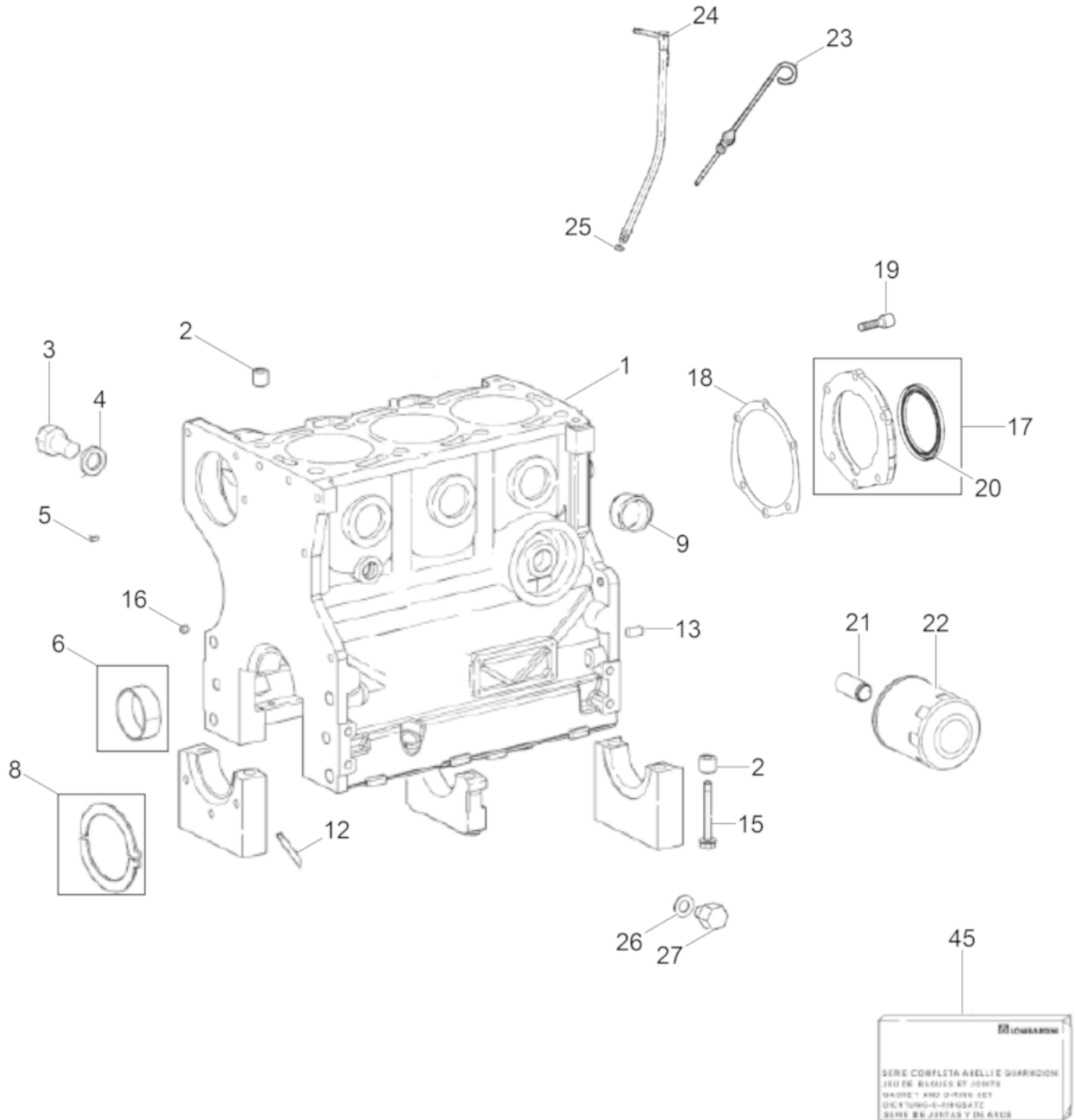

Ref. Pos.	Part No. Artikel Nr.	Qty. St.	Description Beschreibung	Descripción Description	Measurem./Abm.	Norm
					Torque/Drehm.	Sealant Schmierstoff
1	5100008854	1	Crankcase Kurbelgehäuse	Cárter Carter		
2	0159257	2	Sleeve Hülse	Collar Douille		
3	0206229	1	Screw Schraube	Tornillo Vis		
4	0082184	1	Ring seal Dichtring	Anillo sellador Rondelle à étancher		
5	0215522	1	Pin Stift	Espiga Goupille		
6	0155702	3	Bearing Lager	Cojinete Palier		
6	0155703	3	Bearing Lager	Cojinete Palier		
6	0155704	3	Bearing Lager	Cojinete Palier		
8	0159486	2	Washer Scheibe	Disco Rondelle		
8	0159487	2	Disc Scheibe	Disco Disque		
8	0159488	2	Disc Scheibe	Disco Disque		
9	0082335	6	Plug (threaded) Schraubverschluß	Tapón roscado Bouchon		
12	0159288	4	Gasket Dichtung	Junta Joint		
13	0159360	2	Dowel pin Paßstift	Espiga Cheville		
15	0159480	10	Screw Schraube	Tornillo Vis		
16	0159456	1	Plug Stopfen	Tapón Bouchon		
17	0159281	1	Flange Cover Blindflansch	Palanca de Cubierta Semelle		
18	0217807	1	Gasket Dichtung	Junta de estanqueidad Garniture		
19	0217827	6	Hexagonal head cap screw Sechskantschraube	Tornillo hexagonal Vis à tête hexagonale	M6x35	
20	0155701	1	Rotary shaft seal Wellendichtring	Anillo de retén radial Bague d'étanchéité		
21	0159341	1	Fitting-oil filter Ölfilterverschraubung	Unión de filtro de aceite de aceite Raccord de filtre d'huile		
22	5100008858	1	Oil filter Ölfilter	Filtro de aceite Filtre d'huile		
23	5100008859	1	Oil dip stick Ölmesstab	Varilla de sondear aceite Jauge de niveau d'huile		
24	0155739	1	Protection Schutz	Protecciónel de aceite Protection		
25	0063695	2	O-Ring O-Ring	Anillo-O Joint torique		

Crankcase cpl.
Kurbelgehäuse kpl.
Cárter cpl.
Carter cpl.

DPU 130Le

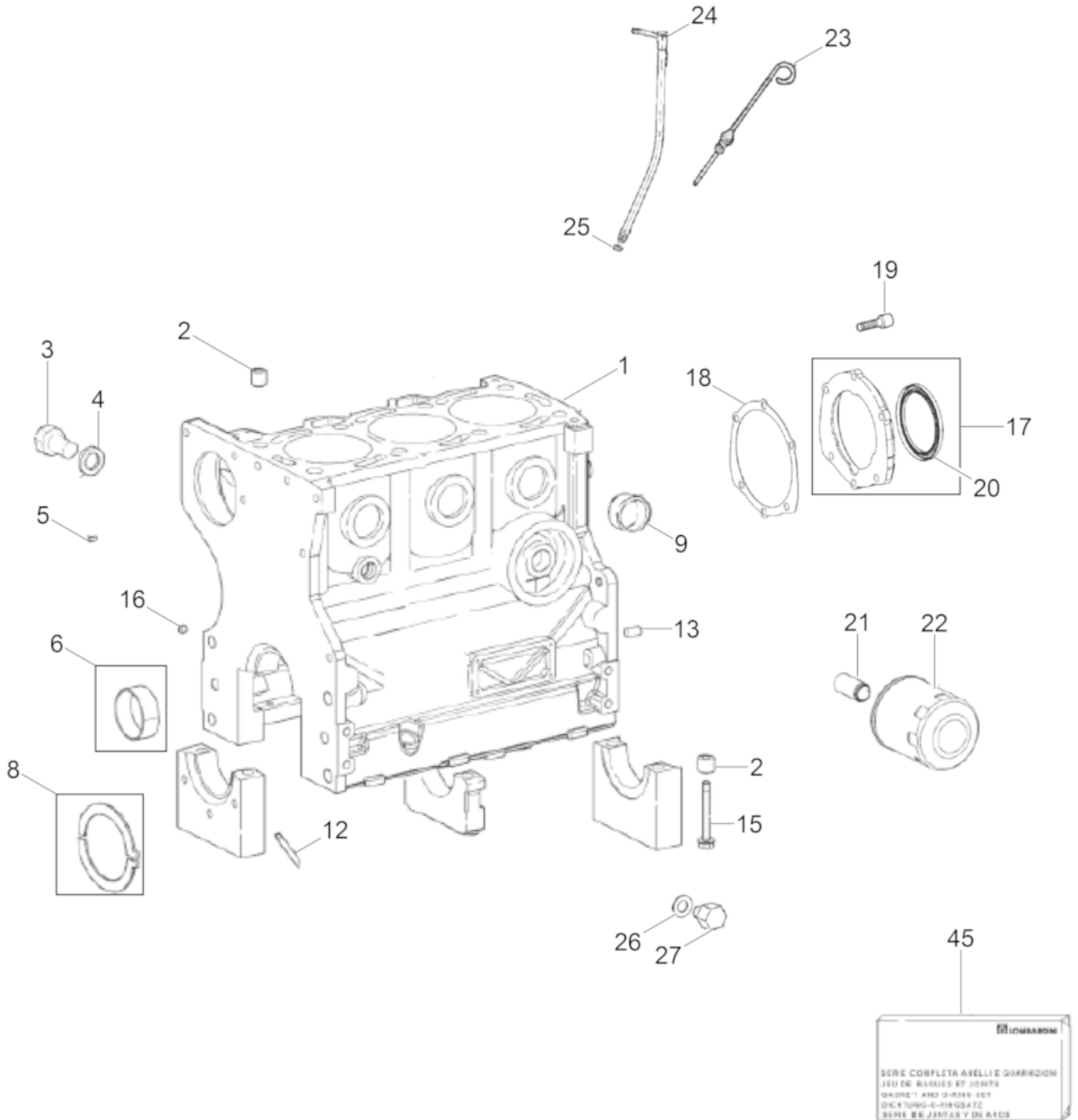

Ref. Pos.	Part No. Artikel Nr.	Qty. St.	Description Beschreibung	Descripción Description	Measur./Abm.	Norm
					Torque/Drehm.	Sealant Schmierstoff
26	0159299	1	Washer Scheibe	Disco Rondelle		
27	0215530	1	Plug Stopfen	Enchufe Prise		
45	0217820	1	Maintenance kit - Crankcase Wartungssatz - Kurbelgehäuse	Juego de reparación - Cárter Jeu d'entretien - Carter		

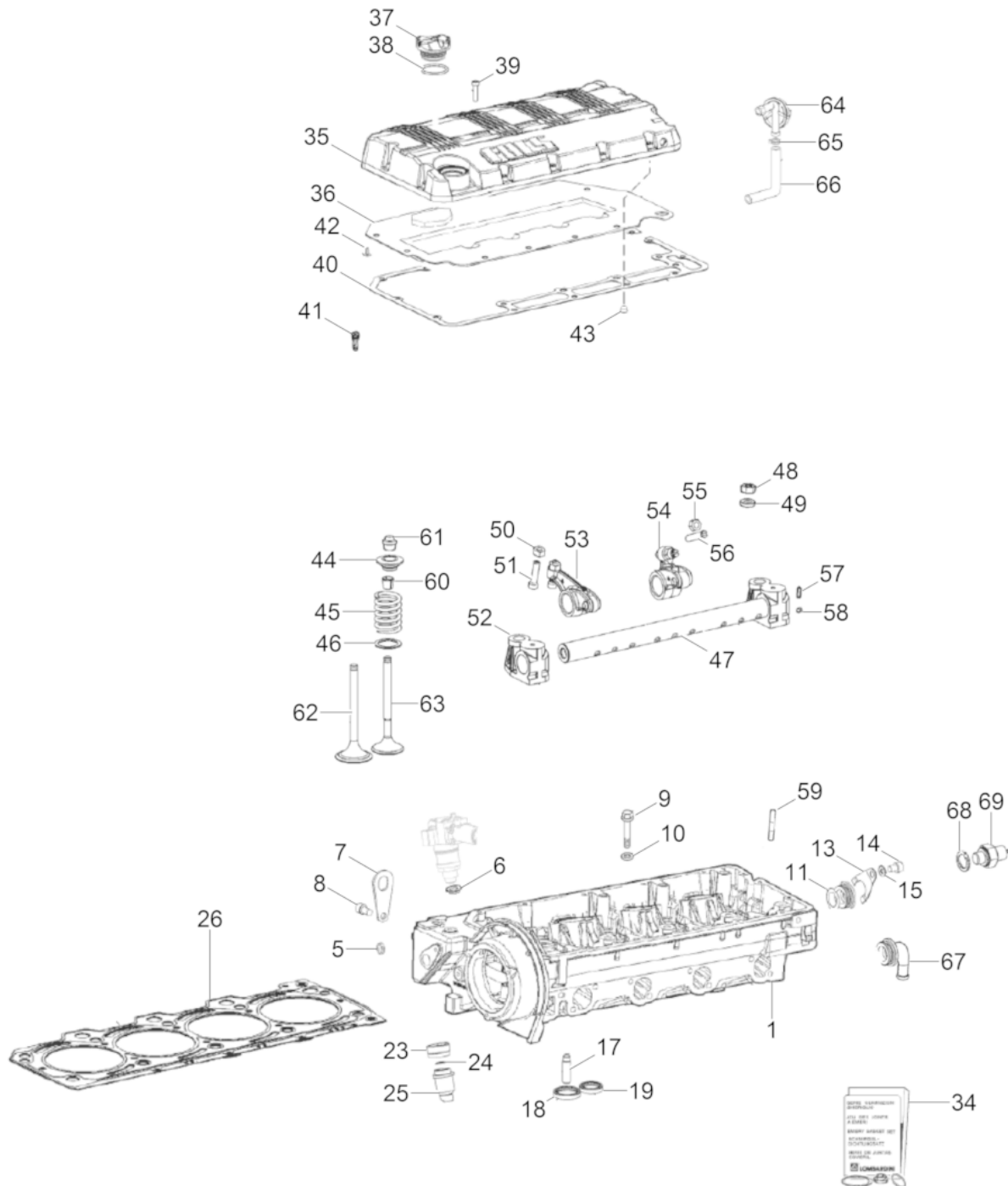

Ref. Pos.	Part No. Artikel Nr.	Qty. St.	Description Beschreibung	Descripción Description	Measurem./Abm.	Norm
					Torque/Drehm.	Sealant Schmierstoff
1	0211354	1	Cylinder Head cpl. Zylinderkopf kpl.	Culata cpl. Culasse cpl.		
5	0159449	6	Plug Stopfen	Enchufe Prise		
6	0159318	4	Spark arrester Funkenfänger	Parachispas Pare-étincelles		
7	0215524	2	Lifting point Aufhängung	Punto para itar Suspension		
8	0084156	1	Screw Schraube	Tornillo Vis		
9	0217828	10	Flange screw Flanschschraube	Tornillo de brida Vis de bride		
10	0159350	10	Washer Scheibe	Arandela Rondelle		
11	0159231	1	O-ring O-ring	Anillo en forma de o Joint torique		
13	0159311	1	Bracket Halter	Soporte Équerre		
14	0159254	1	Bolt Bolzen	Perno Boulon		
15	0082292	1	Washer Scheibe	Arandela Rondelle		
17	0159303	8	Valve guide Ventilführung	Guía de válvula Guide de soupape		
18	0160381	4	Seat-valve, intake Sitz des Einlassventils	Asiento de la válvula de admisión Siège de la soupape		
19	0160382	4	Seat-valve, exhaust Sitz des Auslassventils	Asiento de la válvula de escape Siège de la soupape		
23	0159285	4	Nut Mutter	Tuerca Ecrou		
24	0215494	12	Spacer Abstandsstück	Espaciador Pièce d'écartement		
25	0160380	4	Precombustion chamber Vorkammer	Cámara de precombustión Préchambre		
26	0211353	1	Cylinder head gasket Zylinderkopfdichtung	Junta de culata del cilindro Joint de culasse de cylindre	1,45	
26	0215710	1	Cylinder head gasket Zylinderkopfdichtung	Junta de culata del cilindro Joint de culasse de cylindre	1,55	
26	0215711	1	Cylinder head gasket Zylinderkopfdichtung	Junta de culata del cilindro Joint de culasse de cylindre	1,65	
34	0217819	1	Maintenance kit - Cylinder head Wartungssatz - Zylinderkopf	Juego de reparación - Culata Jeu d'entretien - Culasse		
35	0217803	1	Cover Zylinderkopfdeckel	Tapa Couvercle		
36	0215713	1	Baffle Leitblech	Deflector Déflecteur		
37	0227761	1	Cap Ölverschlussdeckel	Tapa Couvercle		
38	0206208	1	O-ring O-ring	Anillo en forma de o Joint torique		

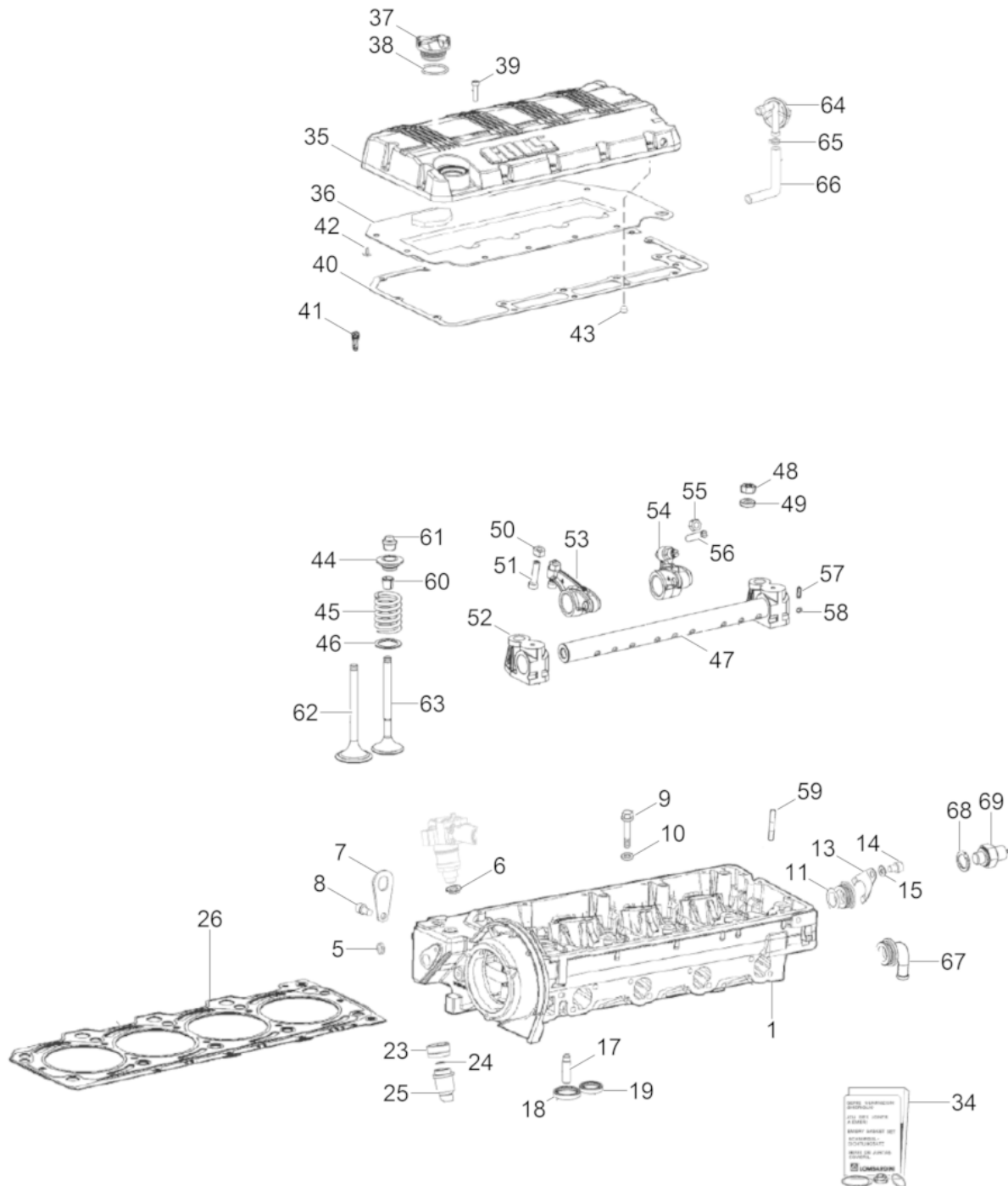

Ref. Pos.	Part No. Artikel Nr.	Qty. St.	Description Beschreibung	Descripción Description	Measur./Abm.	Norm
					Torque/Drehm.	Sealant Schmierstoff
39	0215541	14	Screw Schraube	Tornillo Vis		
40	0211355	1	Gasket Dichtung	Junta de estanqueidad Garniture		
41	0159308	1	Connector Anschlußteil	Conector Connexion		
42	5100008855	12	Rivet Nietnagel	Remache Rivet		
43	0159455	1	Push-in plug Stopfen	Tapón Bouchon		
44	0159328	4	Spring Housing Federgehäuse	Carcasa de Resorte Logement du Ressort		
45	0160373	8	Spring Ventulfeder	Resorte Ressort		
46	0159351	8	Washer Scheibe	Disco Rondelle		
47	0215718	1	Rocker arm cpl. Kipphebel kpl.	Balancín cpl. Culbuteur cpl.		
47	0215717	1	Rocker Shaft Kipphebelwelle	Eje de La Balancín Axe de Culbuteur		
48	0083011	5	Nut Mutter	Tuerca Ecrou		
49	0159350	5	Washer Scheibe	Arandela Rondelle		
50	0159272	1	Nut Mutter	Tuerca Écrou		
51	0159482	1	Screw Schraube	Tornillo Vis		
52	0159447	5	Shaft support Kipphebelbolzenkonsole	Soporte del eje de balancín Support de l'arbre de bascule		
53	0159248	8	Rocker arm Kipphebel	Balancín Culbuteur		
54	0159249	4	Rocker arm injector Kipphebel Einspritzdüse	Inyector de balancines L'injecteur de culbuteur		
55	0159275	1	Nut Mutter	Tuerca Ecrou		
56	0159483	1	Threaded bolt Gewindebolzen	Perno roscado Boulon fileté		
57	0159443	1	Pin Stift	Espiga Goupille		
58	0215529	2	Plug Stopfen	Enchufe Prise		
59	0159333	5	Threaded bolt Gewindebolzen	Perno roscado Boulon fileté		
60	5100008856	16	Bush Buchse	Buje Boîte		
61	0159297	8	Gasket Dichtung	Junta Joint		
62	0160390	4	Intake valve Einlaßventil	Válvula de admisión Soupape d'admission		

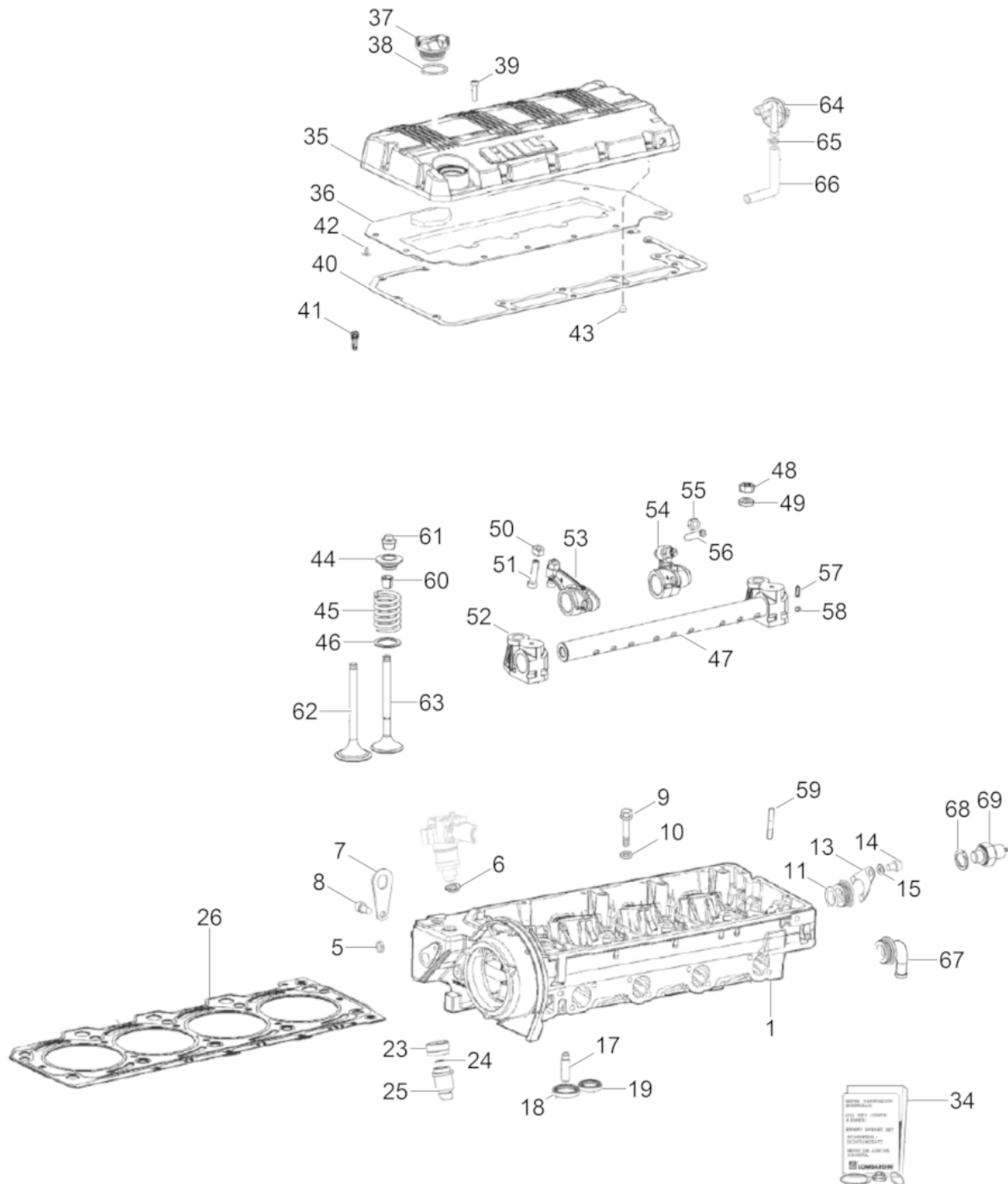

Ref. Pos.	Part No. Artikel Nr.	Qty. St.	Description Beschreibung	Descripción Description	Measurement./Abm.	Norm
					Torque/Drehm.	Sealant Schmierstoff
63	0160392	4	Outlet valve Auslaßventil	Válvula de escape Soupape d'échappement		
64	0102140	4	Pressure relief valve Überdruckventil	Válvula de sobrepresión Soupape de surpression		
65	0160201	2	Clamp Schelle	Abrazadera Attache		
66	0159460	1	Tube Rohr	Tubo Tube		
67	0159453	1	Plug Stopfen	Enchufe Prise		
68	0082184	1	Ring seal Dichtring	Anillo sellador Rondelle à étancher		
69	5100006062	1	Oil pressure switch Öldruckschalter	Interruptor de presión de aceite Interrupteur à pression		

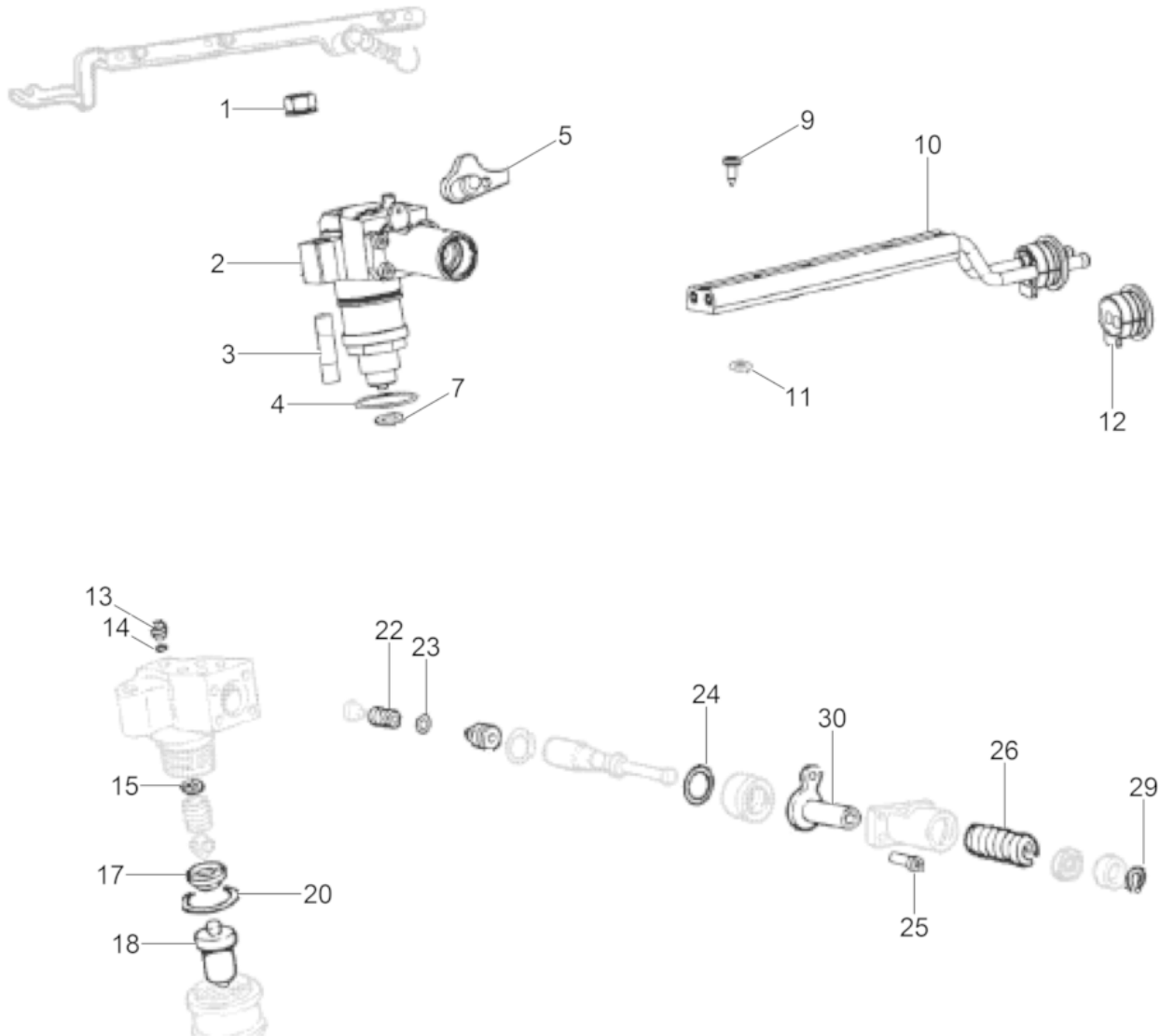

Ref. Pos.	Part No. Artikel Nr.	Qty. St.	Description Beschreibung	Descripción Description	Measurem./Abm.	Norm
					Torque/Drehm.	Sealant Schmierstoff
1	0063700	8	Flange nut Flanschmutter	Tuerca de reborde Ecrou de bride		
2	0160379	4	Injection pump Einspritzpumpe	Bomba de inyección Pompe à injection		
3	5200009479	8	Stud Gewindebolzen	Perno prisionero Goujon		
4	0159233	2	O-Ring O-Ring	Anillo-O Joint torique		
5	0159325	1	Plate Platte	Placa Plaque		
7	0159300	4	Washer Scheibe	Disco Rondelle		
9	0159473	8	Screw Schraube	Tornillo Vis		
10	0211363	1	Fuel hose Kraftstoffleitung	Manguera de combustible Tuyau à essence		
11	0159237	2	Ring Ring	Anillo Anneau		
12	0160209	1	Gasket Dichtung	Junta de estanqueidad Garniture		
13	0160391	2	Back pressure valve Rückschlagventil	Válvula de retención Soupape de retenue		
14	0159302	2	Gasket Dichtung	Junta de estanqueidad Garniture		
15	0160332	1	Spacer Abstandsstück	Espaciador Pièce d'écartement		
15	0160342	1	Spacer Abstandsstück	Espaciador Pièce d'écartement		
15	0160341	1	Spacer Abstandsstück	Espaciador Pièce d'écartement		
15	0160340	1	Spacer Abstandsstück	Espaciador Pièce d'écartement		
15	0160339	1	Spacer Abstandsstück	Espaciador Pièce d'écartement		
15	0160338	1	Spacer Abstandsstück	Espaciador Pièce d'écartement		
15	0160337	1	Spacer Abstandsstück	Espaciador Pièce d'écartement		
15	0160336	1	Spacer Abstandsstück	Espaciador Pièce d'écartement		
15	0160335	1	Spacer Abstandsstück	Espaciador Pièce d'écartement		
15	0160334	1	Spacer Abstandsstück	Espaciador Pièce d'écartement		
17	0159278	2	Spacer Abstandsstück	Espaciador Pièce d'écartement		
18	0155710	2	Jet Düse	Chicler Gicleur		
20	0159238	2	O-ring O-Ring	Anillo-O Bague-O		

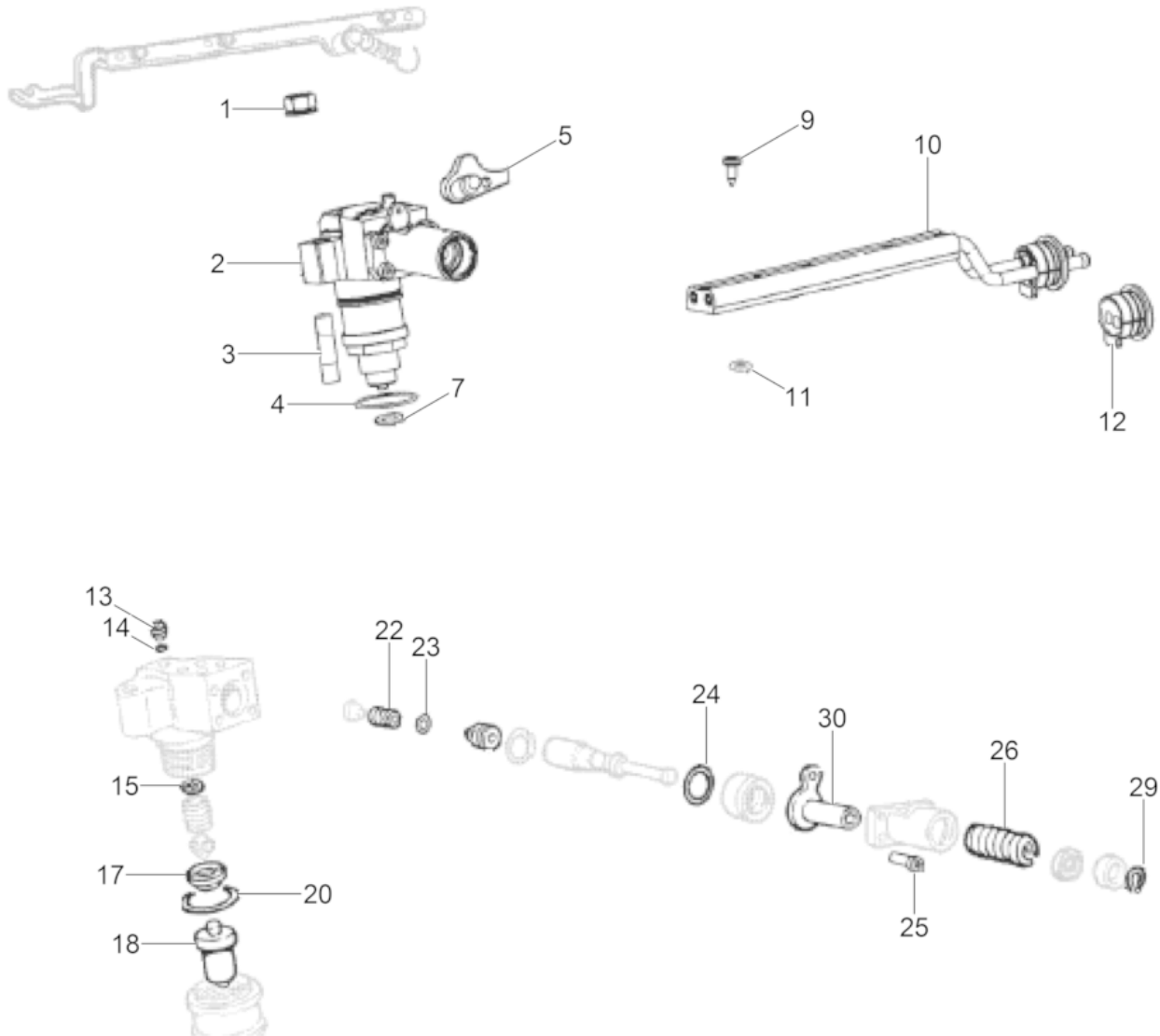

Ref. Pos.	Part No. Artikel Nr.	Qty. St.	Description Beschreibung	Descripción Description	Measurement./Abm.	Norm
					Torque/Drehm.	Sealant Schmierstoff
22	0215509	2	Spring Feder	Resorte Ressort		
23	0203718	2	Cu-Ring Cu-Ring	Cu-Anillo Cu-Anneau		
24	0159236	2	Ring Ring	Anillo Anneau		
25	0159471	4	Screw Schraube	Tornillo Vis		
26	0159317	2	Spring Feder	Resorte Ressort		
29	0159242	2	Clamp Klemme	Abrazadera Pince		
30	0155707	2	Fuel cock Kraftstoffhahn	Llave de combustible Robinet d'essence		
32	0159309	2	Shim Ausgleichscheibe	Laminata Cale		

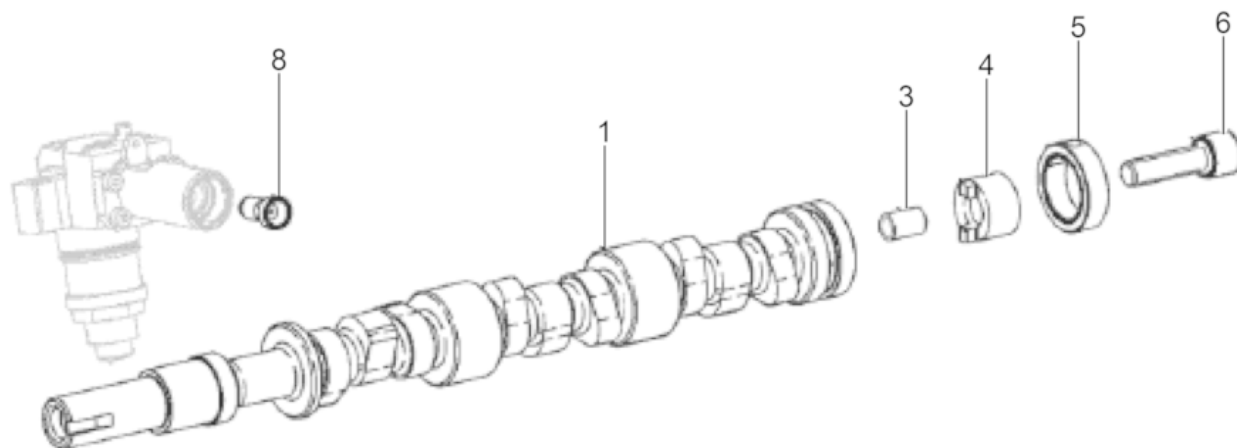

Ref. Pos.	Part No. Artikel Nr.	Qty. St.	Description Beschreibung	Descripción Description	Measurement./Abm.	Norm
					Torque/Drehm.	Sealant Schmierstoff
1	0215688	1	Camshaft Nockenwelle	Árbol de Levas Arbre à Cames		
3	0215482	1	Collar Hülse	Collar Douille		
4	0215497	1	Cam Nocken	Leva Came		
5	0160753	1	Injector cam Einspritznocken	Leva inyectora Came d'injection		
6	0215540	1	Screw Schraube	Tornillo Vis		
8	0159246	4	Push rod (valve lifter) Stoßstange	Levantaválvula Poussoir de soupape		

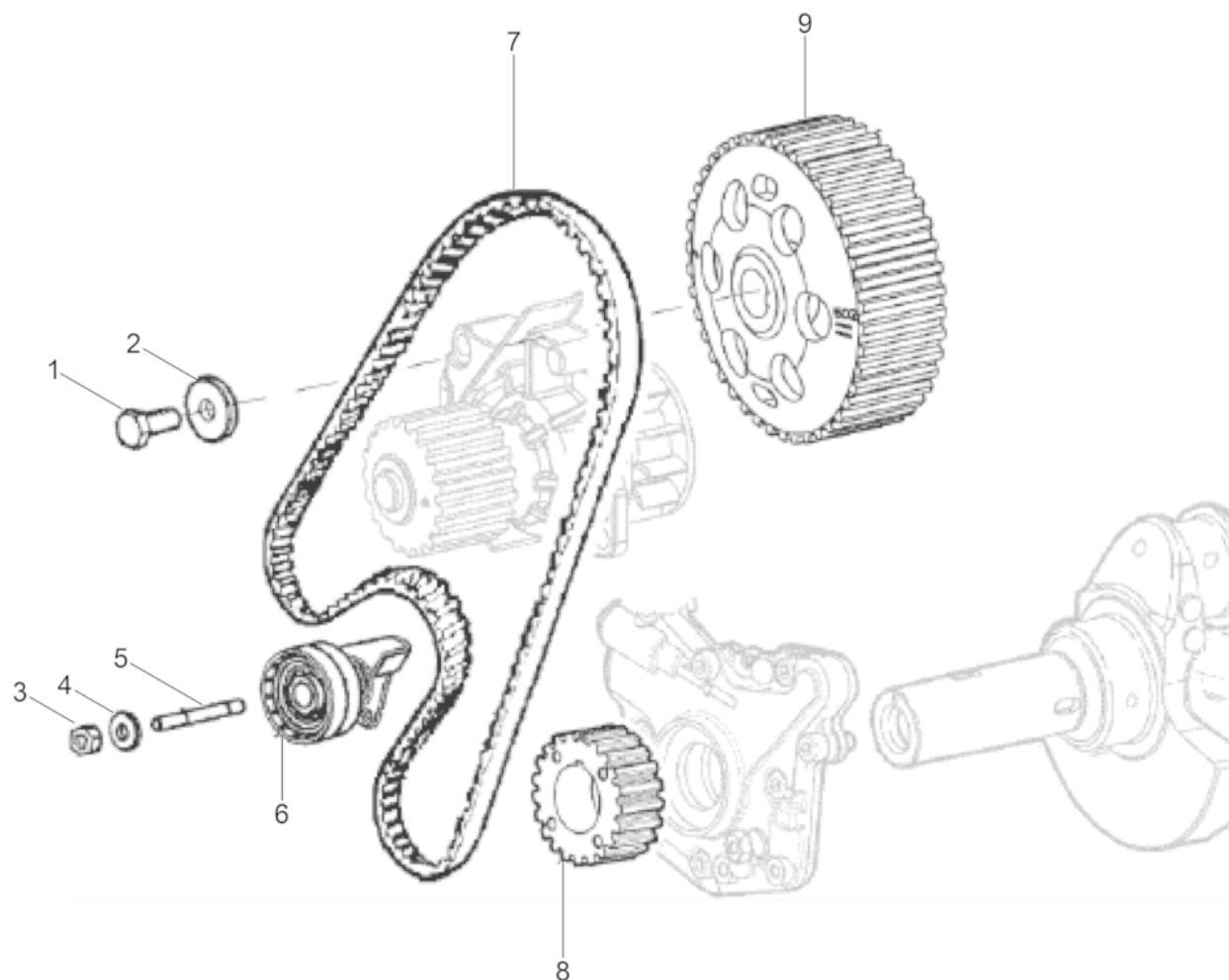

Ref. Pos.	Part No. Artikel Nr.	Qty. St.	Description Beschreibung	Descripción Description	Measurement./Abm.	Norm
					Torque/Drehm.	Sealant Schmierstoff
1	0159481	1	Screw Schraube	Tornillo Vis		
2	0159349	1	Washer Scheibe	Disco Rondelle		
3	0083011	1	Nut Mutter	Tuerca Ecrou		
4	0159344	1	Washer Scheibe	Disco Rondelle		
5	0159334	1	Threaded bolt Gewindebolzen	Perno roscado Boulon fileté		
6	0159284	1	Tensioner pulley Spannrolle	Polea tensora Poulie de tension		
7	0155697	1	Timing belt Synchronriemen	Correa de sincronización Courroie de synchronisation		
8	0159336	1	V-belt pulley Riemenscheibe	Polea Poulie		
9	0159338	1	V-belt pulley Riemenscheibe	Polea Poulie		

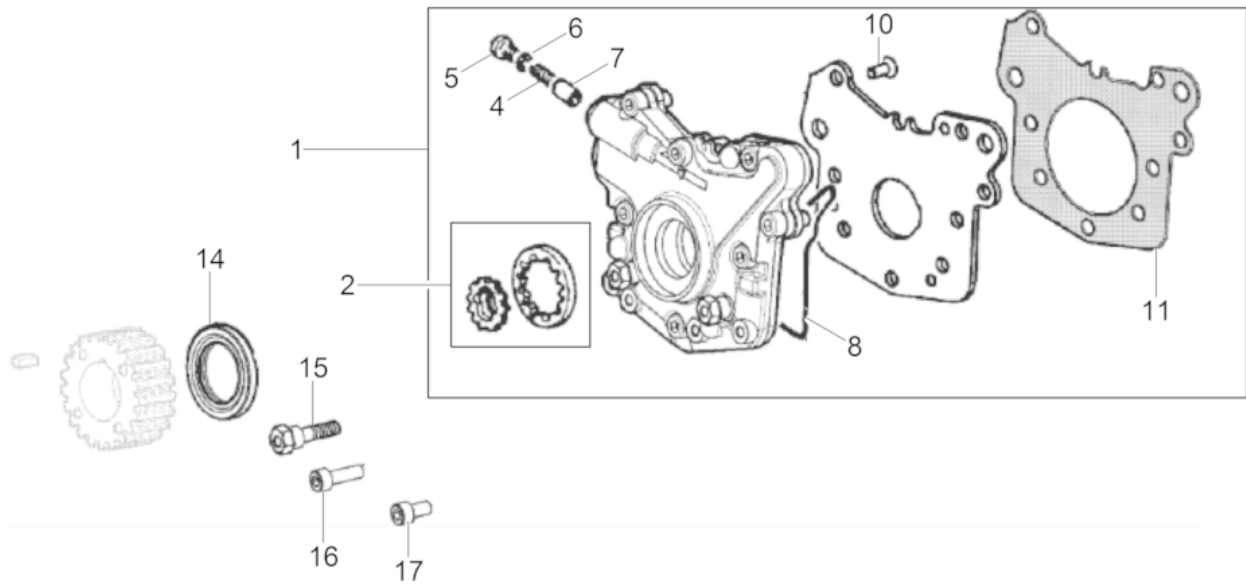

Ref. Pos.	Part No. Artikel Nr.	Qty. St.	Description Beschreibung	Descripción Description	Measurement./Abm.	Norm
					Torque/Drehm.	Sealant Schmierstoff
1	0211359	1	Oil pump cpl. Ölpumpe kpl.	Bomba de aceite cpl. Pompe à huile cpl.		
2	0215729	1	Pump impeller Pumpenräder	Impulsor Turbine		
4	0159312	1	Spring Feder	Resorte Ressort		
5	0082184	1	Ring seal Dichtring	Anillo sellador Rondelle à étancher		
6	0082184	1	Ring seal Dichtring	Anillo sellador Rondelle à étancher		
7	0159330	1	Rod Stange	Varilla Tige		
8	0160178	1	O-Ring O-Ring	Anillo-O Joint torique		
10	0159478	1	Screw Schraube	Tornillo Vis		
11	0155734	1	Ring seal Dichtungsring	Anillo sellador Rondelle à étancher		
14	0155734	1	Ring seal Dichtungsring	Anillo sellador Rondelle à étancher		
15	5000159784	2	Inlet valve Einlaßventil	Válvula de admisión Soupape d'admission		
16	0215479	1	Hexagonal head cap screw Sechskantschraube	Tornillo hexagonal Vis à tête hexagonale		
17	0084169	6	Screw Schraube	tornillo vis		

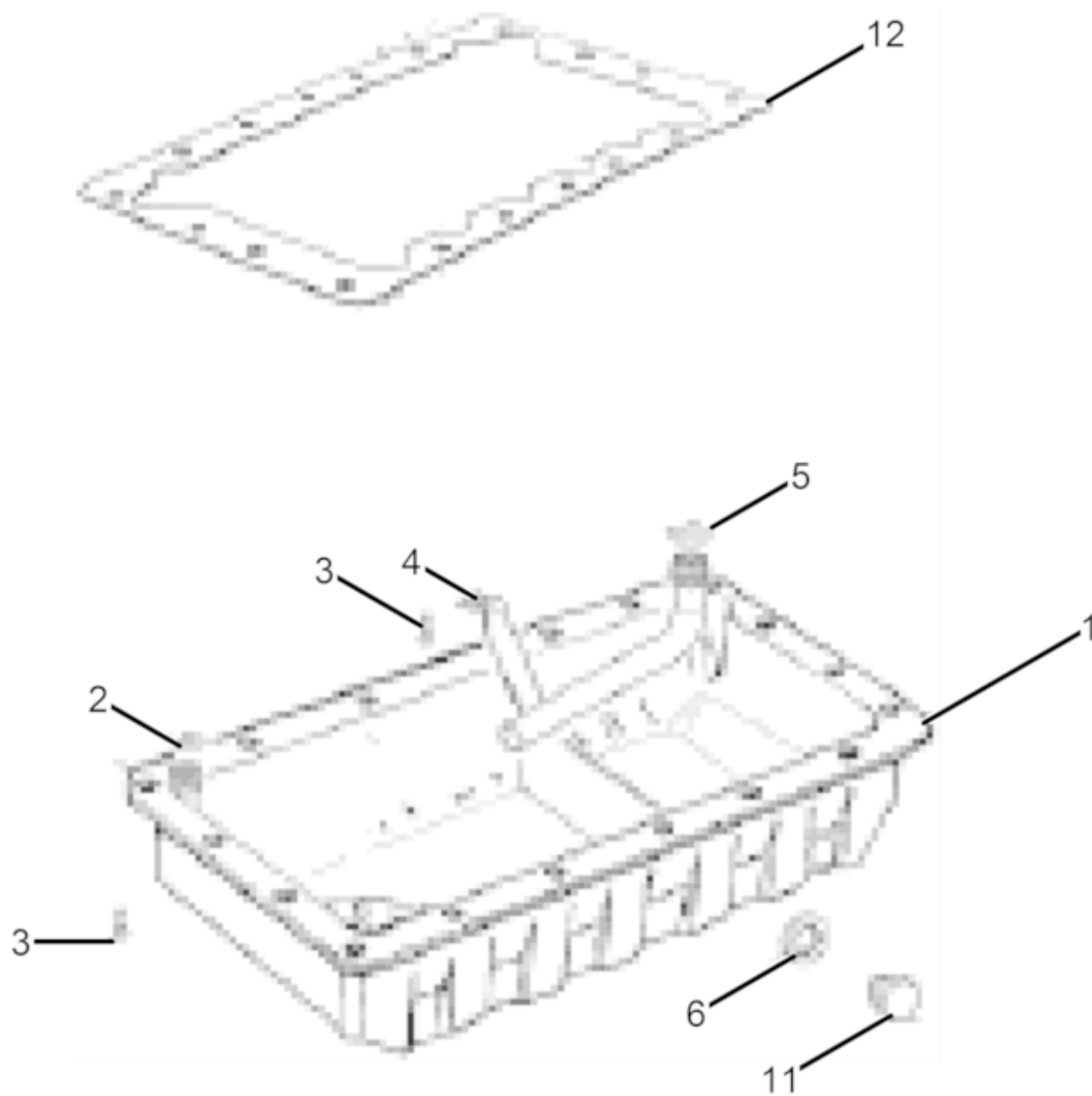

Ref. Pos.	Part No. Artikel Nr.	Qty. St.	Description Beschreibung	Descripción Description	Measurement./Abm.	Norm
					Torque/Drehm.	Sealant Schmierstoff
1	0211360	1	Oil pan Ölwanne	Carter de Aceite Cuvette Carter à Huile		
2	0159228	1	Oil Seal Öldichtung	Junta de Aceite Joint D'Huile		
3	0159253	23	Bolt Bolzen	Perno Boulon		
4	5100008857	1	Oil pipe Ölleitung	Tubería dolio Tuyau à huile		
5	0159235	1	O-Ring O-Ring	Anillo-O Joint torique		
6	5000159535	2	Exhaust valve guide Auslassventilführung	Guía de válvula de escape Guide de soupape d'échappement		
11	0211364	2	Screw Plug Verschlusschraube	Tapón Roscado Vis de Fermeture		
12	0215712	1	Gasket Dichtung	Junta Joint		

Speed control module
Drehzahlregler
Controlador de velocidad
Régulateur de vitesse

DPU 130Le

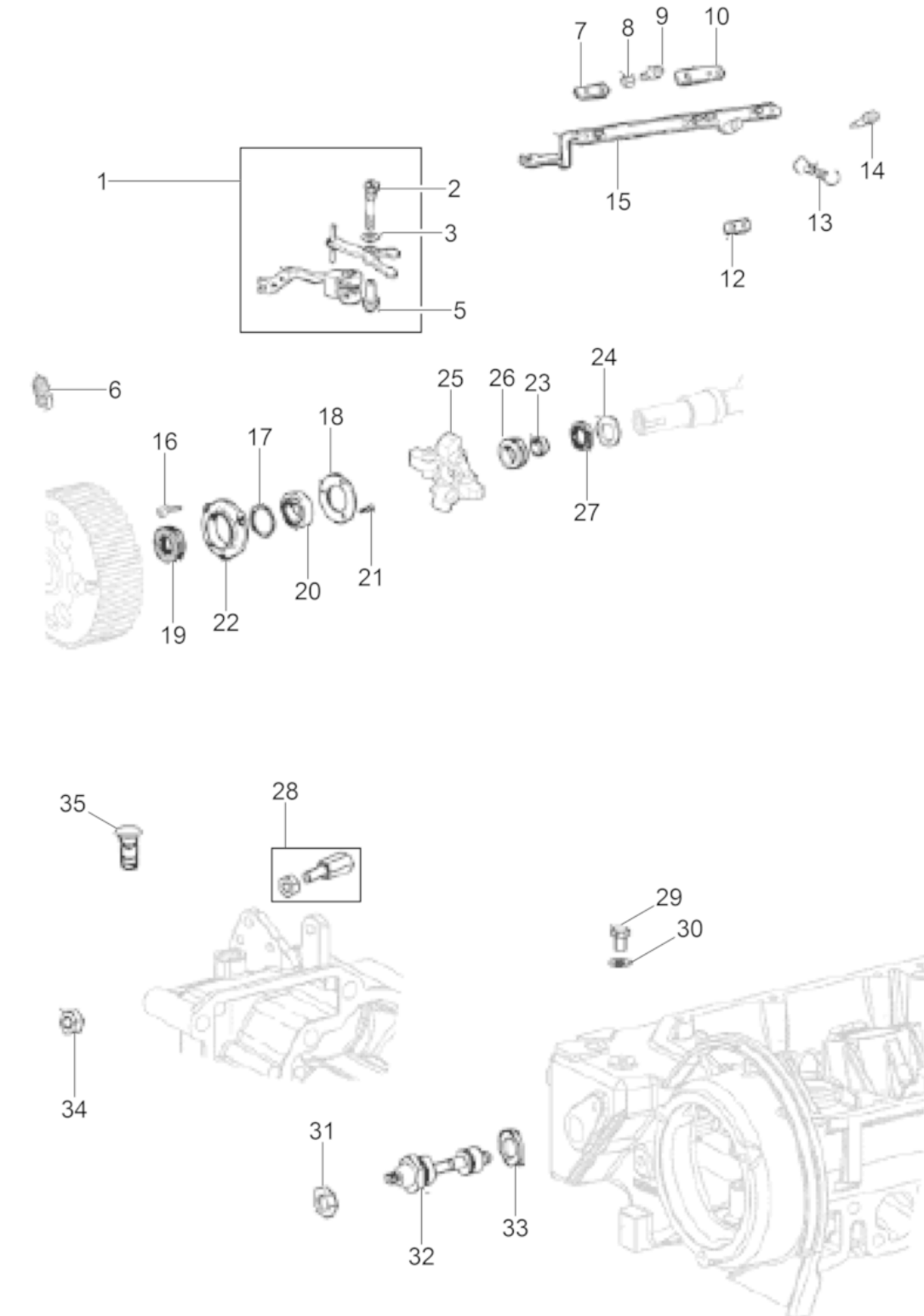

Ref. Pos.	Part No. Artikel Nr.	Qty. St.	Description Beschreibung	Descripción Description	Measurem./Abm.	Norm
					Torque/Drehm.	Sealant Schmierstoff
1	0159304	1	Governor lever cpl. Reglerhebel kpl.	Palanca de regulador cpl. Levier régulateur cpl.		
2	0159321	1	Pin Stift	Espiga Goupille		
3	0159229	1	Oil Seal Öldichtung	Junta de Aceite Joint D'Huile		
5	0215480	1	Collar Hülse	Collar Douille		
6	0215507	1	Spring Feder	Resorte Ressort		
7	0217813	1	Plate Platte	Placa Plaque		
8	0215520	2	Washer Scheibe	Disco Rondelle		
9	0159477	6	Screw Schraube	Tornillo Vis		
12	0160220	2	Plate Platte	Placa Plaque		
13	0159315	1	Spring Feder	Resorte Ressort		
14	0211941	4	Screw Schraube	Tornillo Vis		
15	0215691	1	Rods Gestänge	Varillaje Tiges		
16	0159467	3	Cover Deckel	Cubierta Couvercle		
17	0159239	1	O-Ring O-Ring	Anillo-O Joint torique		
18	0159324	1	Check disc Anlaufscheibe	Arandela tope Disque		
19	0159240	1	Lip seal Lippendichtung	Retén labial Joint à lèvres		
20	0159267	1	Collar Hülse	Collar Douille		
21	5100008841	3	Screw Schraube	Tornillo Vis		
22	0159265	1	Cover Deckel	Cubierta Couvercle		
23	0159251	1	Collar Hülse	Collar Douille		
24	0215517	1	Check disc Anlaufscheibe	Arandela tope Disque		
25	0155698	1	Speed control module Drehzahlregler	Controlador de velocidad Régulateur de vitesse		
26	0215506	1	Collar Hülse	Collar Douille		
27	0217805	1	Bearing Anlauflager	Cojinete Palier		
28	0209040	1	Screw Einstellschraube	Tornillo Vis		

Speed control module
Drehzahlregler
Controlador de velocidad
Régulateur de vitesse

DPU 130Le

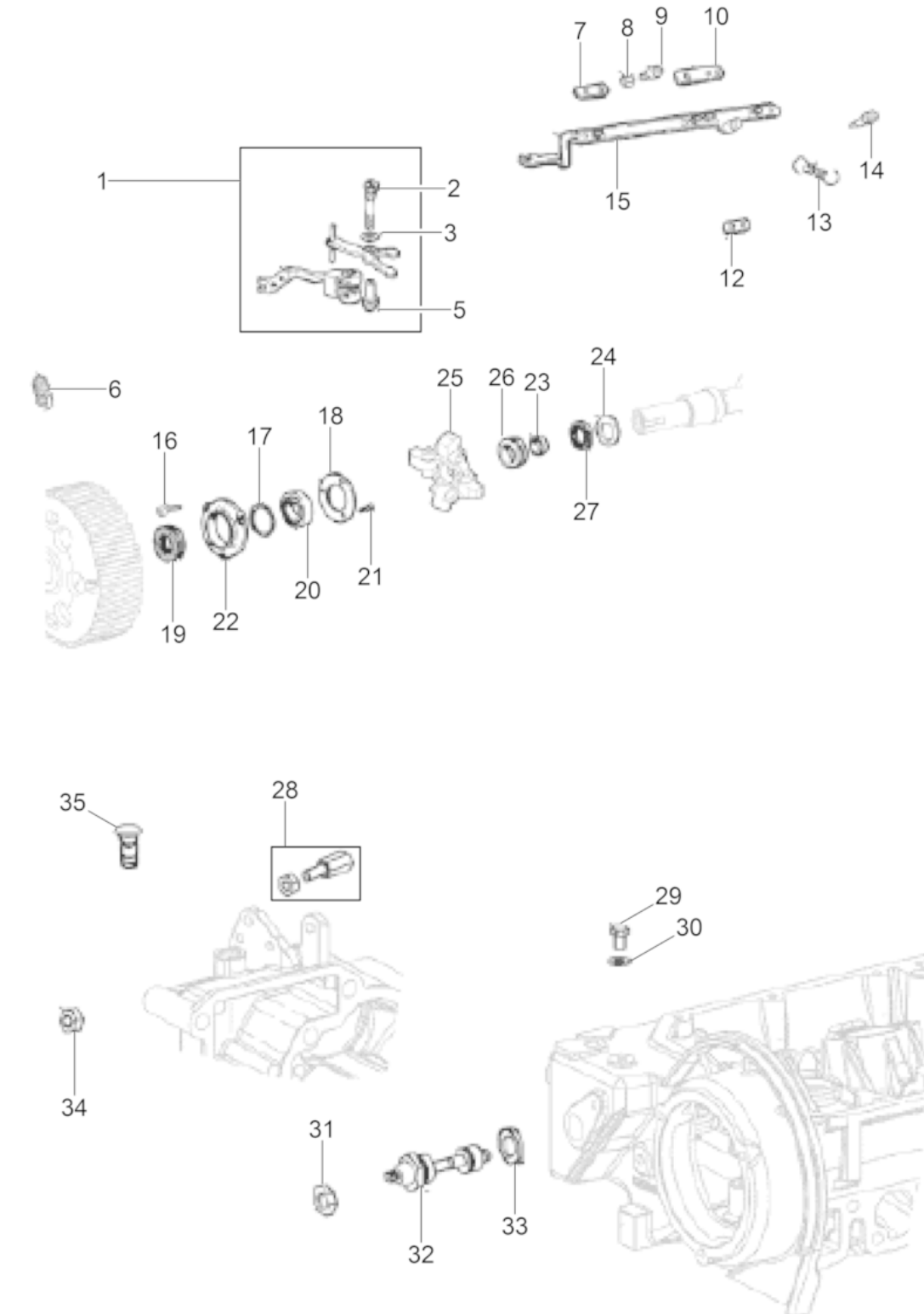

Ref. Pos.	Part No. Artikel Nr.	Qty. St.	Description Beschreibung	Descripción Description	Measurement./Abm.	Norm
					Torque/Drehm.	Sealant Schmierstoff
29	0084131	2	Screw Schraube	Tornillo Vis		
30	0083995	2	Washer Scheibe	Arandela Rondelle		
31	0159276	1	Nut Mutter	Tuerca Écrou		
32	0217822	1	Extra Fuel Device Startfüllung	Sobrealimentación-Arranque Surcharge		
33	0159292	1	Gasket Dichtung	Junta de estanqueidad Garniture		
34	0159272	1	Nut Mutter	Tuerca Écrou		
35	0215528	1	Plug Stopfen	Tapón Bouchon		

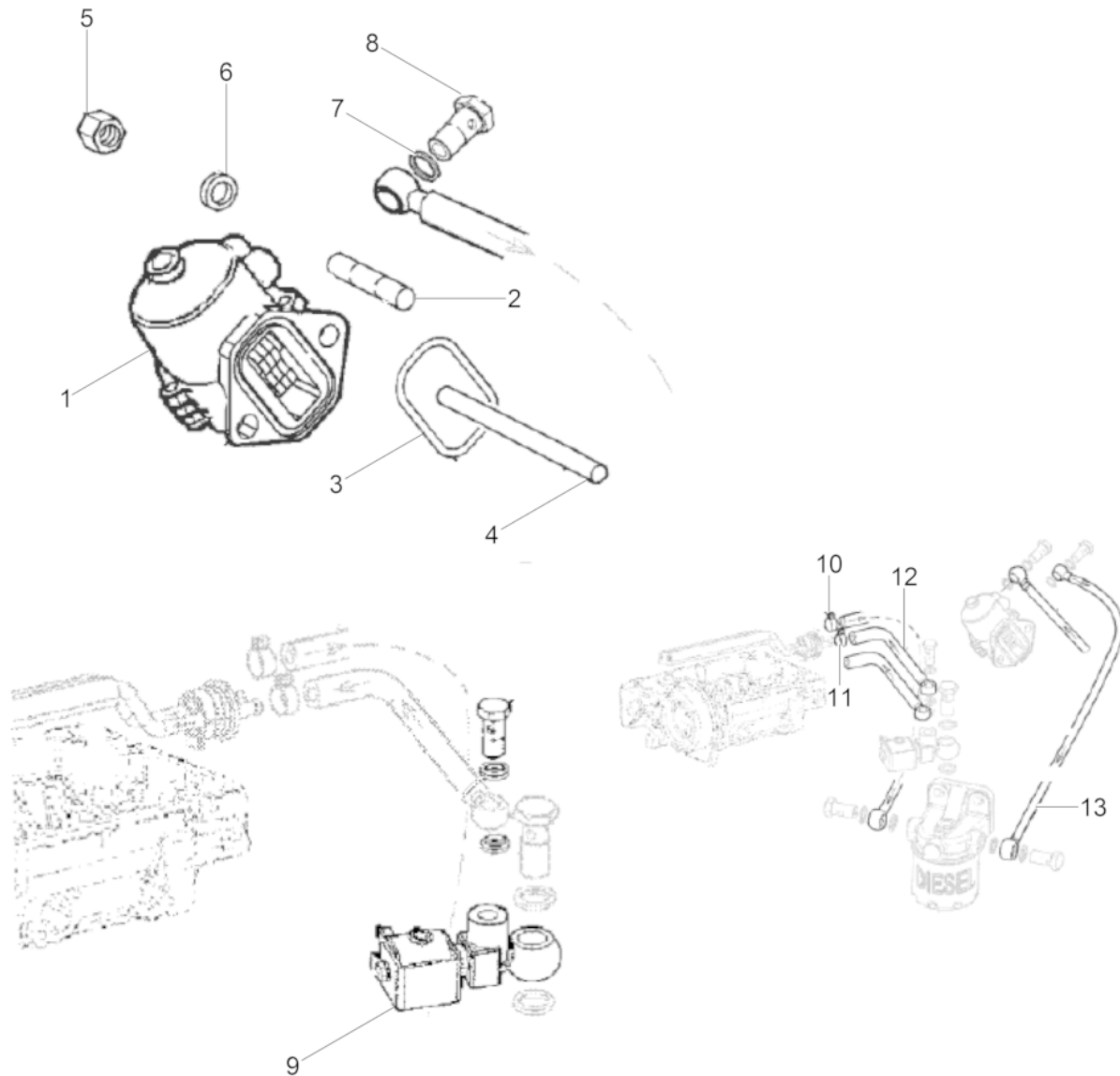

Ref. Pos.	Part No. Artikel Nr.	Qty. St.	Description Beschreibung	Descripción Description	Measurement./Abm.	Norm
					Torque/Drehm.	Sealant Schmierstoff
1	0226239	1	Fuel Pump Kraftstoffpumpe	Bomba de Combustible Pompe à Essence		
2	0082266	2	Stud Stiftschraube	Perno prisionero Boulon		
3	0110759	1	Seal Dichtung	Junta Joint		
4	0160757	1	Rod Stange	Varillae Tige		
5	0063700	2	Flange nut Flanschmutter	Tuerca de reborde Ecrou de bride		
6	0082285	2	Washer Scheibe	Arandela Rondelle		
7	0209052	4	Gasket-copper Kupferdichtung	Junta de cobre Joint en cuivre		
8	0217802	2	Banjo bolt Hohlschraube	Perno hueco Boulon creux à filet femelle		
9	0155711	1	Fuel valve Kraftstoffventil	Grifo de combustible Robinet de carburant		
10	0082155	1	Clamp Schelle	Abrazadera Collier		
11	0215704	1	Clamp Schelle	Abrazadera Attache		
12	0217956	1	Fuel hose Kraftstoffleitung	Manguera de combustible Tuyau à essence		
13	0206596	1	Fuel hose Kraftstoffleitung	Manguera de combustible Tuyau à essence		
14	0217957	1	Fuel hose Kraftstoffleitung	Manguera de combustible Tuyau à essence		

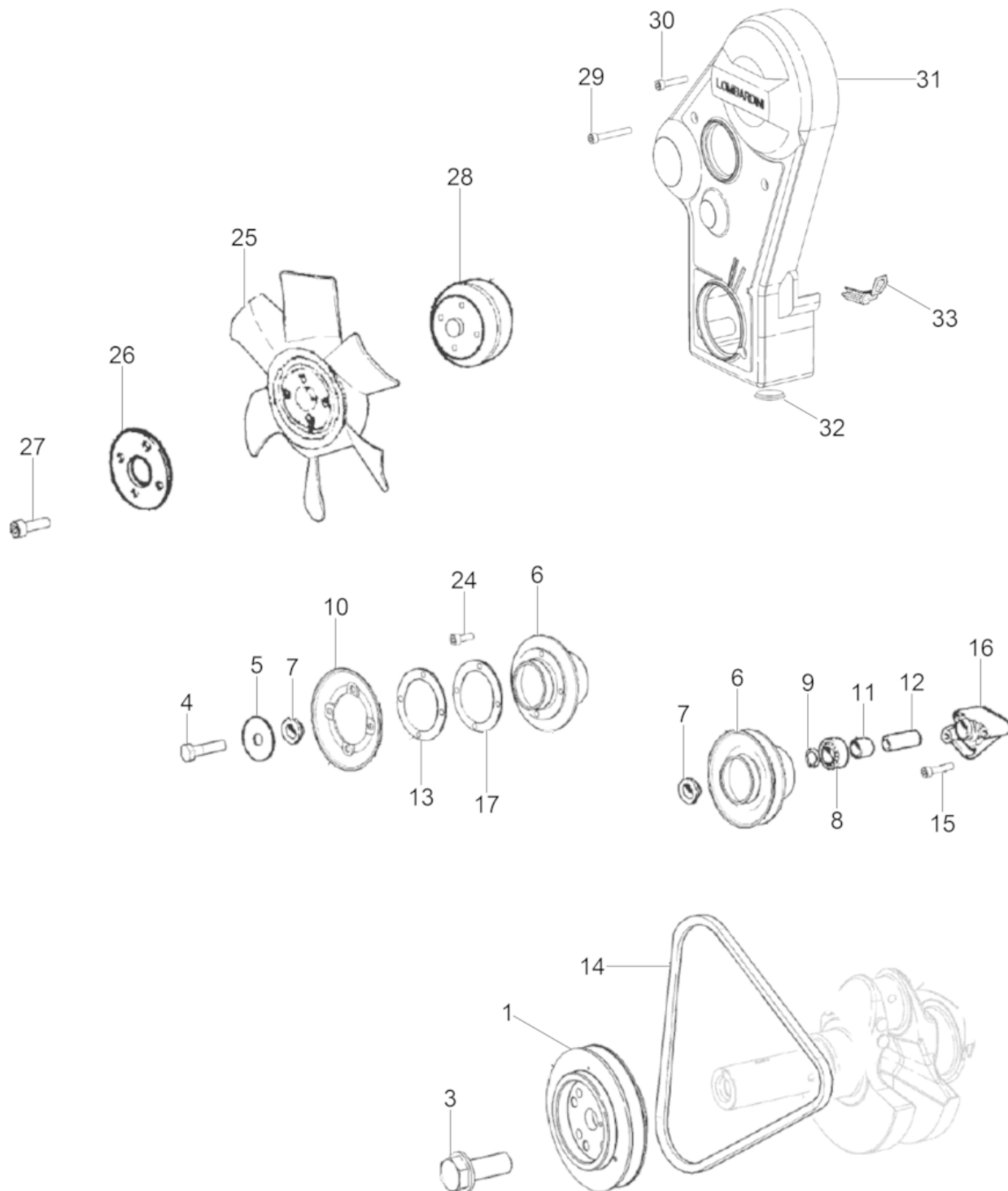

Ref. Pos.	Part No. Artikel Nr.	Qty. St.	Description Beschreibung	Descripción Description	Measurem./Abm.	Norm
					Torque/Drehm.	Sealant Schmierstoff
1	0155723	1	Crankshaft pulley Scheibe	Disco Rondelle		
3	0126935	1	Bolt Bolzen	Perno Boulon		
4	0159490	1	Bolt Bolzen	Perno Boulon	M8x1.25x90	
5	0159346	1	Washer Scheibe	Disco Rondelle		
6	0159345	1	Pulley cpl. Konsole kpl.	Consola cpl. Console cpl.		
6	510008853	1	V-belt pulley Riemenscheibe	Polea Poulie		
7	0159347	1	Washer Scheibe	Disco Rondelle		
8	0082135	2	Bearing Lager	Cojinete Palier		
9	0159241	2	Retaining ring Sicherungsring	Anillo de retención Bague d'arrêt		
10	0207987	1	V-belt pulley half Riemenscheibenhälfte	Semi polea en V Flanc de poulie à courroie		
11	0159277	1	Spacer Abstandsstück	Espaciador Pièce d'écartement		
12	0159489	1	Pin Stift	Espiga Goupille	63,5	
13	0207988	2	Distance washer Abstandsscheibe	Arandela distanciador Rondelle intermédiaire	0,5	
14	0159262	1	Belt Riemen	Correa Courroie		
15	0083026	3	Screw Schraube	Tornillo Vis	M8x35	
16	0159448	1	Console Konsole	Consola Console		
17	0207989	4	Distance washer Abstandsscheibe	Arandela distanciador Rondelle intermédiaire	1,0	
24	0159475	4	Screw Schraube	tornillo vis		
25	0217826	1	Fan wheel Lüfterrad	Rueda del ventilador Roue d'aération		
26	0159323	1	Plate Platte	Placa Plaque		
27	0207992	4	Screw Schraube	Tornillo Vis		
28	0215498	1	Flange Flansch	Brida Bride	43,5mm	
29	0159564	1	Screw Schraube	Tornillo Vis		
30	0159475	4	Screw Schraube	tornillo vis		
31	0217815	1	Belt guard Riemenschutz	Protección de la polea Protection de courroie		

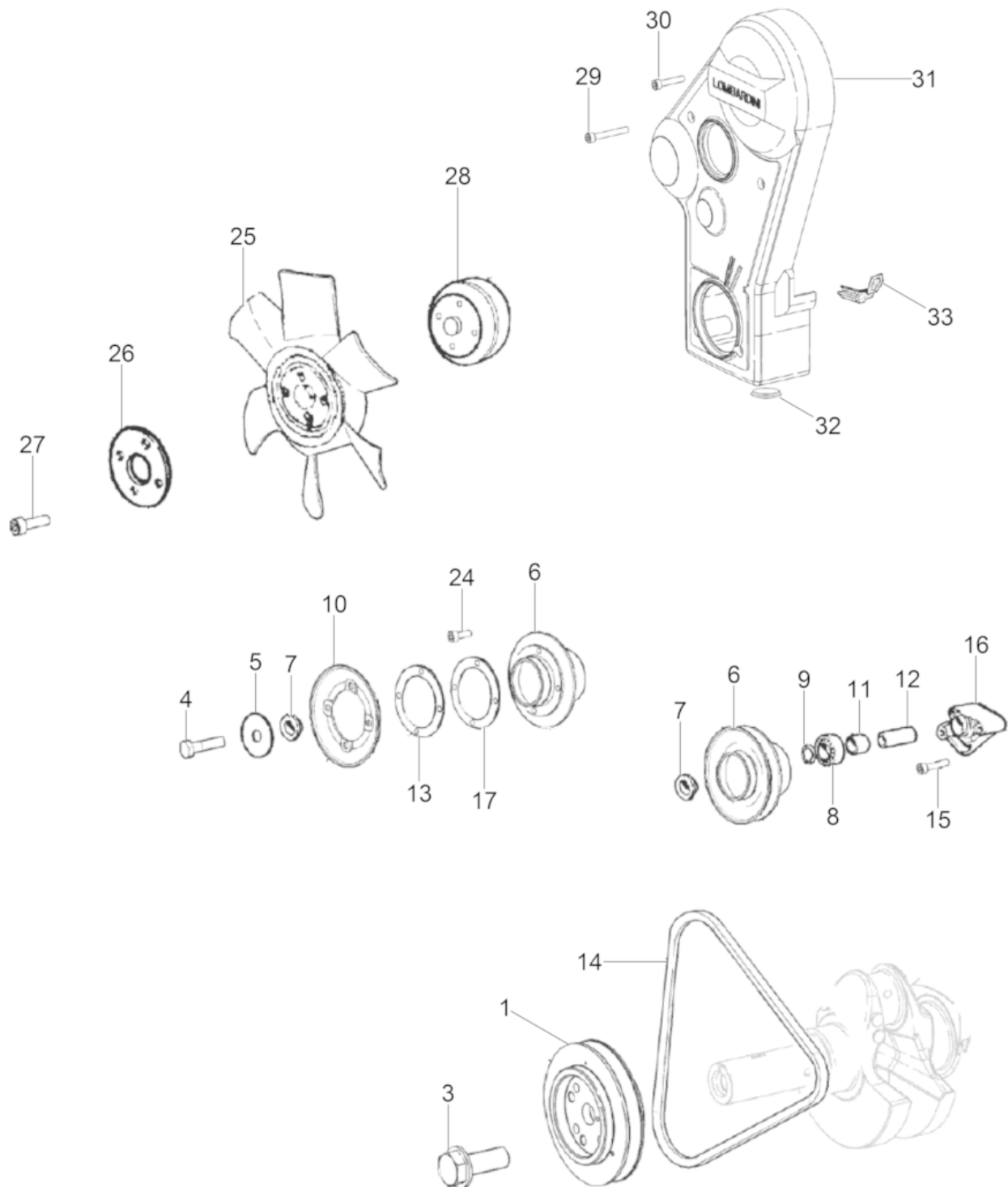

Ref. Pos.	Part No. Artikel Nr.	Qty. St.	Description Beschreibung	Descripción Description	Measurem./Abm.	Norm
					Torque/Drehm.	Sealant Schmierstoff
32	0159268	1	Plug Stopfen	Enchufe Prise		
33	0215499	1	Gasket Dichtung	Junta de estanqueidad Garniture		

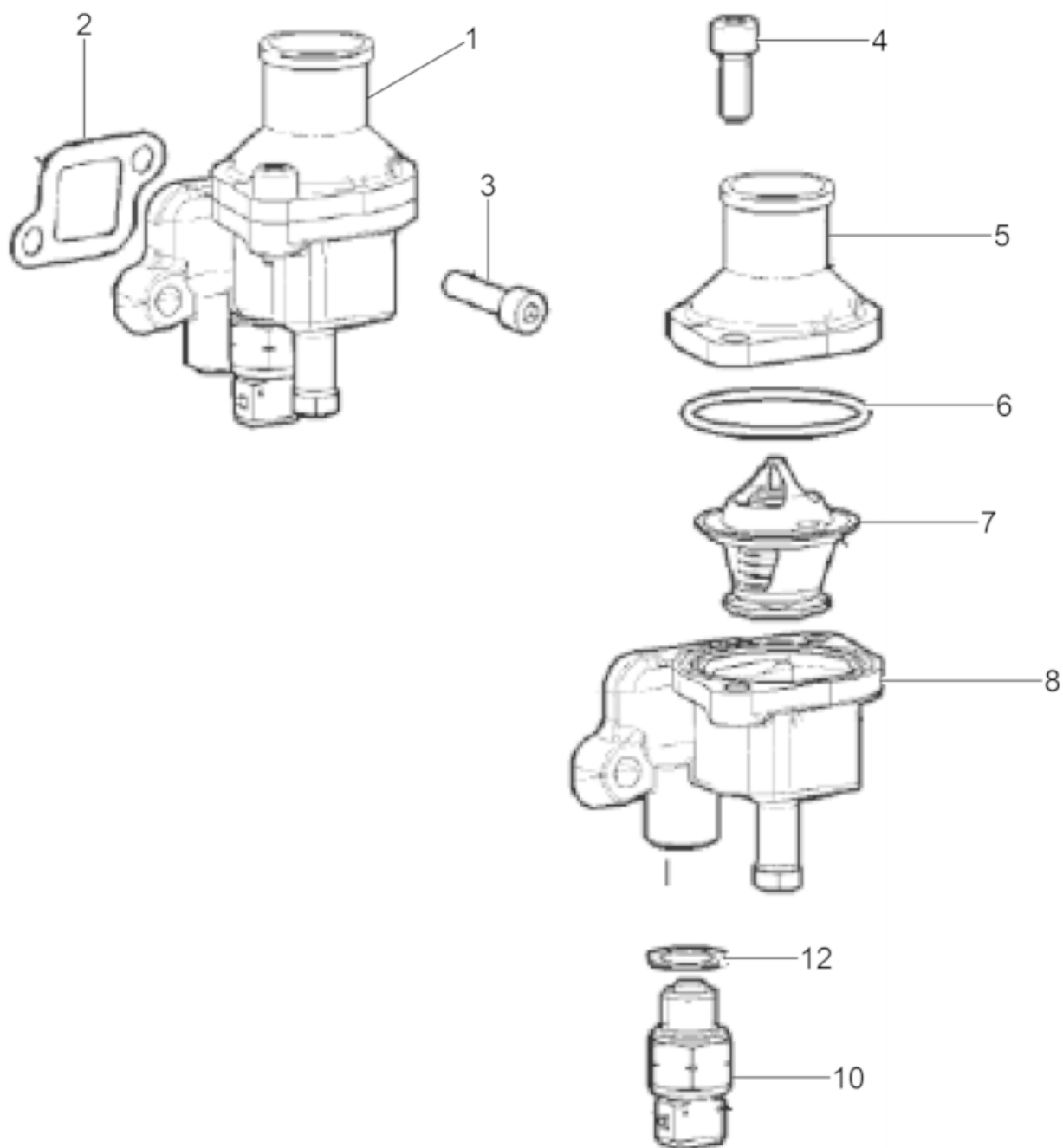

Ref. Pos.	Part No. Artikel Nr.	Qty. St.	Description Beschreibung	Descripción Description	Measurem./Abm.	Norm
					Torque/Drehm.	Sealant Schmierstoff
1	0211377	1	Thermostat cpl. Thermostat kpl.	Termóstato cpl. Thermostat cpl.		
2	0211378	1	Gasket Dichtung	Junta de estanqueidad Garniture		
3	0159476	2	Screw Schraube	Tornillo Vis		
4	0084169	2	Screw Schraube	tornillo vis		
5	0211376	1	Cover Deckel	Cubierta Couvercle		
6	0159232	1	O-Ring O-Ring	Anillo-O Joint torique		
7	0207002	1	Valve-thermostat Thermostatventil	Válvula de gobierno termostático Soupape thermostatique		
8	0211375	1	Housing Gehäuse	Carcasa Enveloppe		
10	0160387	1	Sensor Sensoreinheit	Unidad de alertaa Appareil d'alerte		
12	0159299	1	Washer Scheibe	Disco Rondelle		

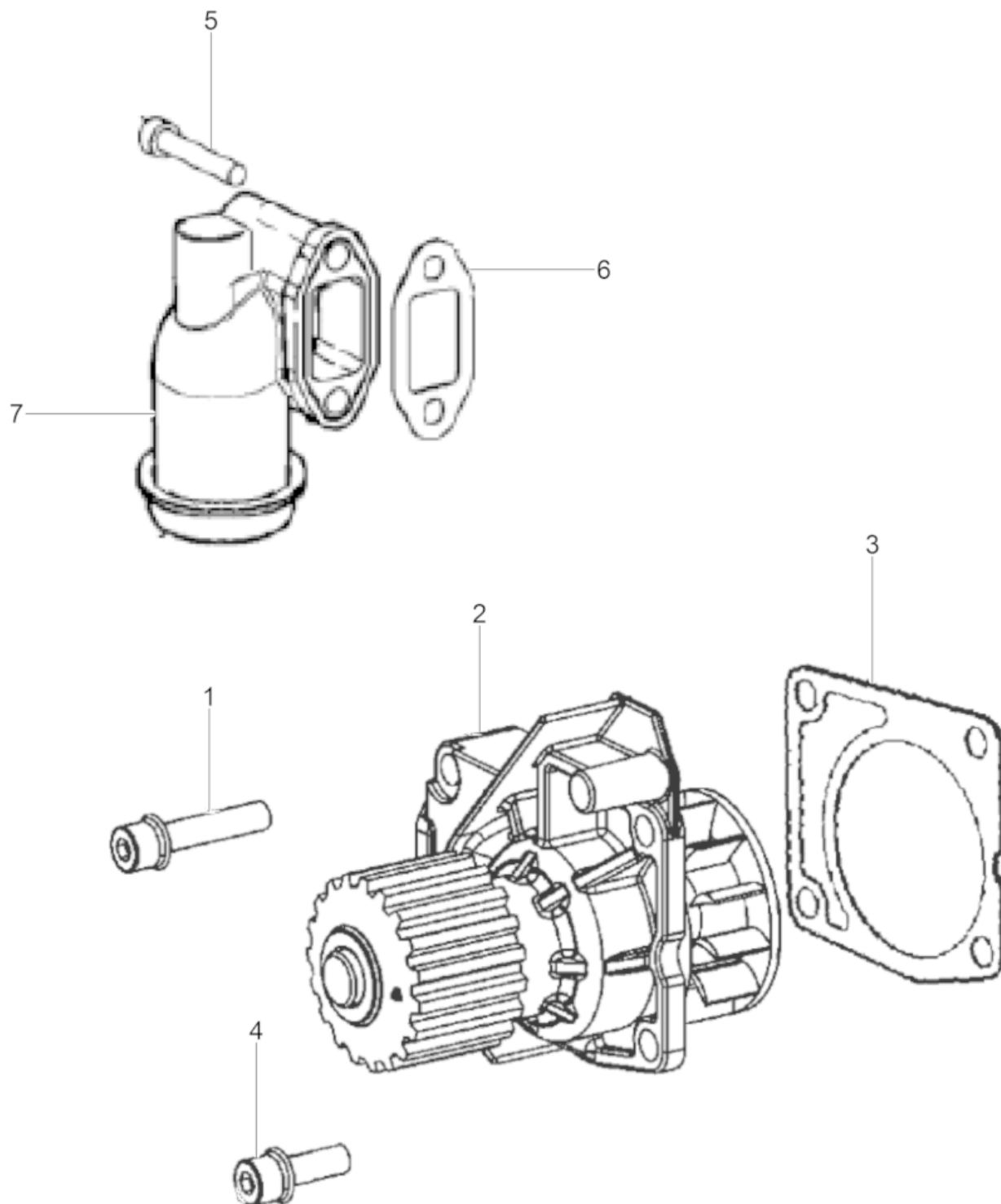

Ref. Pos.	Part No. Artikel Nr.	Qty. St.	Description Beschreibung	Descripción Description	Measurement./Abm.	Norm
					Torque/Drehm.	Sealant Schmierstoff
1	0209105	2	Hexagonal head cap screw Sechskantschraube	Tornillo hexagonal Vis à tête hexagonale		
2	0211358	1	Water pump cpl. Wasserpumpe kpl.	Bomba de agua cpl. Pompe à eau cpl.		
3	0217809	1	Gasket Dichtung	Junta de estanqueidad Garniture		
4	0209107	2	Hexagonal head cap screw Sechskantschraube	Tornillo hexagonal Vis à tête hexagonale		
5	0160362	2	Screw Schraube	Tornillo Vis		
6	0217808	1	Gasket Dichtung	Junta de estanqueidad Garniture		
7	0211374	1	Flange Flansch	Brida Bride		

Inlet bend
Ansaugkrümmer
Codo de aspiración
Coude d'aspiration

DPU 130Le

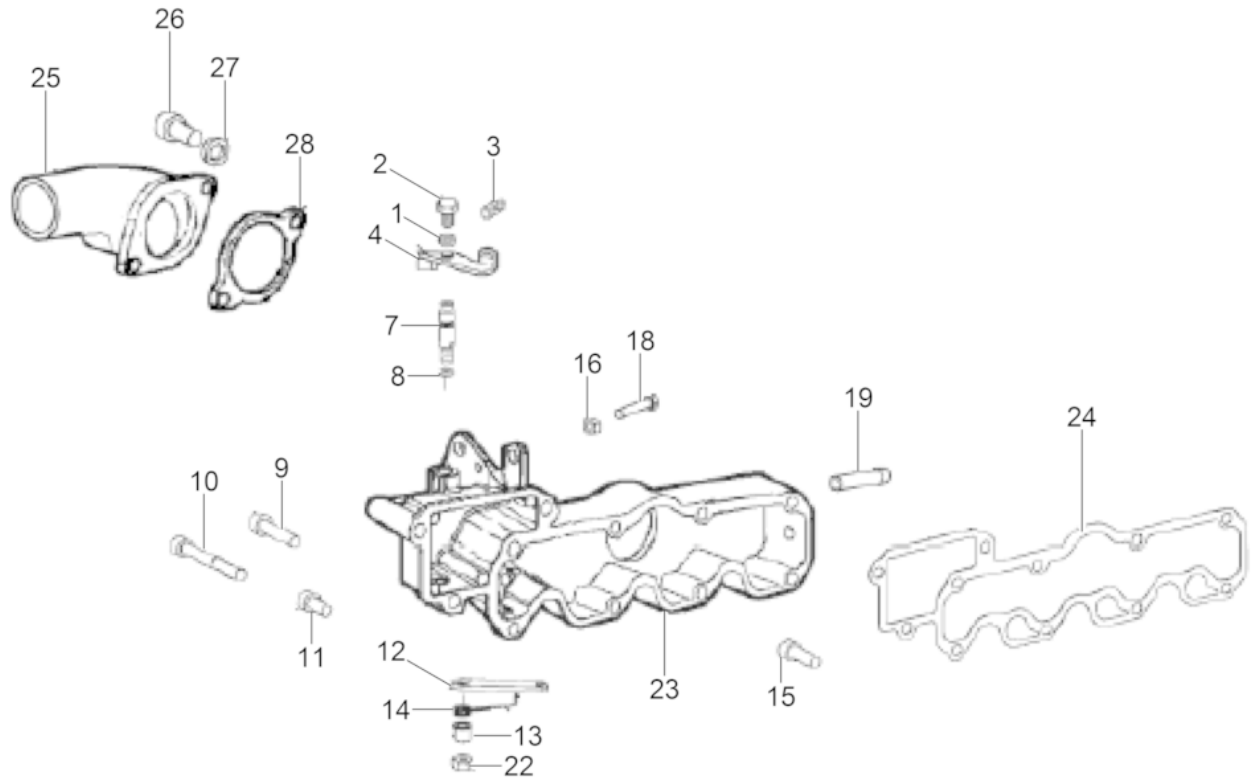

Ref. Pos.	Part No. Artikel Nr.	Qty. St.	Description Beschreibung	Descripción Description	Measur./Abm.	Norm
					Torque/Drehm.	Sealant Schmierstoff
1	0217817	1	Washer Scheibe	Disco Rondelle		
2	0217801	1	Hexagonal head cap screw Sechskantschraube	Tornillo hexagonal Vis à tête hexagonale		
3	0203352	1	Clamping piece Klemmstück	Pieza de fijación Pièce de serrage		
4	0217810	1	Lever Hebel	Palanca Levier		
7	5100008860	1	Shaft Welle	Eje Arbre		
8	0159230	1	Oil Seal Öldichtung	Junta de Aceite Joint D'Huile		
9	0083026	1	Screw Schraube	Tornillo Vis	M8x35	
10	0084170	1	Screw Schraube	Tornillo Vis		
11	0159476	4	Screw Schraube	Tornillo Vis		
12	0215504	1	Lever Hebel	Palanca Levier		
13	0215481	1	Collar Hülse	Collar Douille		
14	0215508	1	Spring Feder	Resorte Ressort		
15	0203346	5	Screw Schraube	tornillo vis		
16	0159272	2	Nut Mutter	Tuerca Écrou		
18	5100008861	2	Hexagonal head cap screw Sechskantschraube	Tornillo hexagonal Vis à tête hexagonale		
20	0159462	1	Hose Schlauch	Manguera Boyau		
22	0084232	1	Nut Mutter	Tuerca Ecrou		
23	0211367	1	Distributor Verteiler	Distribuidor Distributeur		
24	0211368	1	Gasket Dichtung	Junta de estanqueidad Garniture		
25	0215706	1	Flange Flansch	Brida Collerette		
26	0084169	2	Screw Schraube	tornillo vis		
27	0082285	2	Washer Scheibe	Arandela Rondelle		
28	0159294	1	Gasket Dichtung	Junta de estanqueidad Garniture		

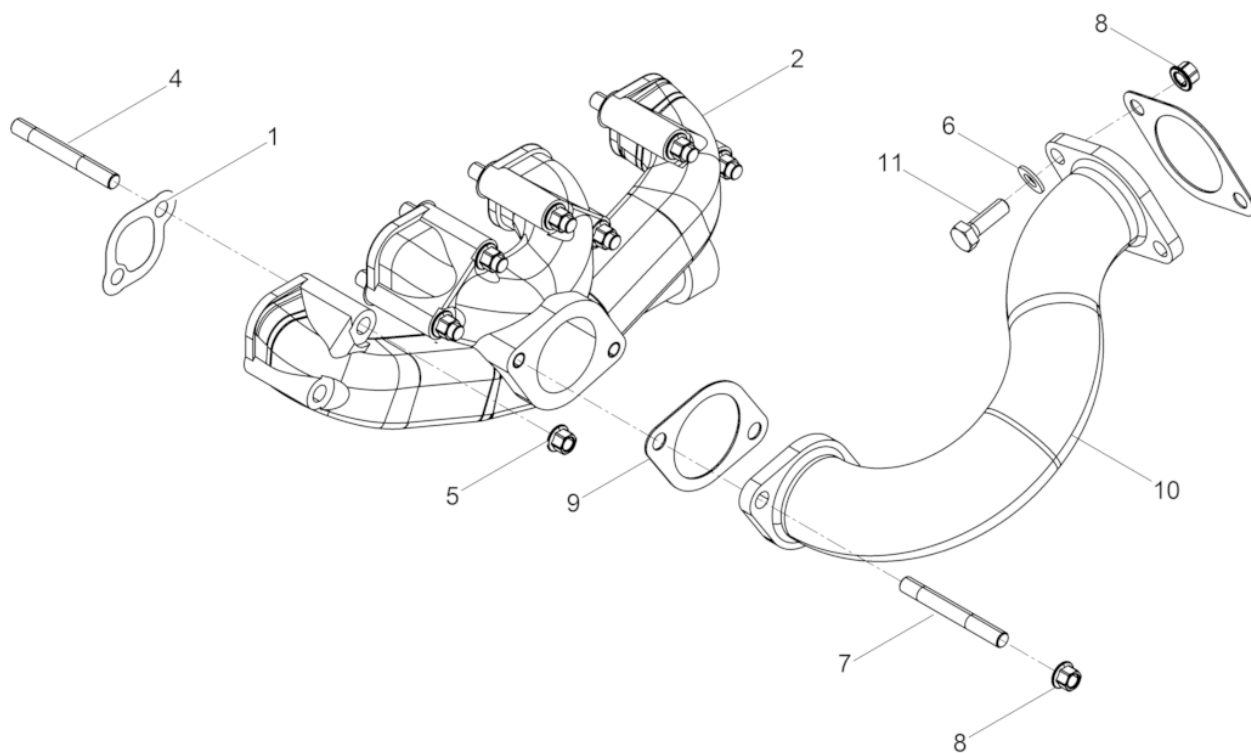

Ref. Pos.	Part No. Artikel Nr.	Qty. St.	Description Beschreibung	Descripción Description	Measurement./Abm.	Norm
					Torque/Drehm.	Sealant Schmierstoff
1	0159290	4	Gasket Dichtung	Junta de estanqueidad Garniture		
2	0211366	1	Exhaust manifold Auspuffkrümmer	Múltiple de escape Coude d'échappement		
4	0082267	8	Stud Gewindebolzen	Perno prisionero Boulon		
5	0086331	8	Nut Mutter	Tuerca Écrou		
6	0082288	2	Washer Scheibe	Arandela Rondelle		
7	0160228	2	Threaded bolt Gewindebolzen	Perno roscado Boulon fileté	M8x22	
8	0086331	4	Nut Mutter	Tuerca Écrou		
9	0159295	2	Gasket Dichtung	Junta de estanqueidad Garniture		
10	0206435	1	Exhaust pipe Auspuffrohr	Tubo de escape Tube d'échappement		
11	0215479	2	Hexagonal head cap screw Sechskantschraube	Tornillo hexagonal Vis à tête hexagonale		

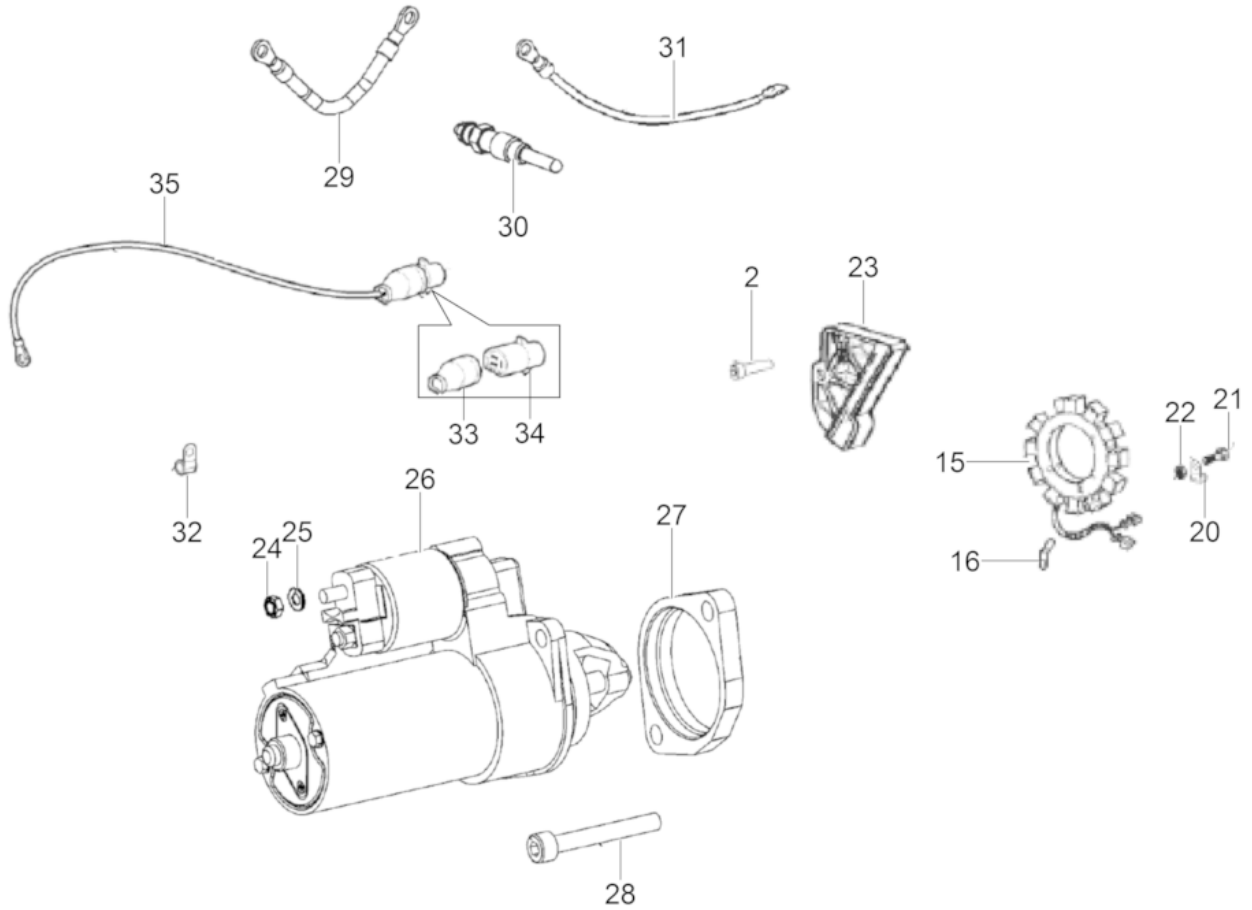

Ref. Pos.	Part No. Artikel Nr.	Qty. St.	Description Beschreibung	Descripción Description	Measurem./Abm.	Norm
					Torque/Drehm.	Sealant Schmierstoff
1	0159476	2	Screw Schraube	Tornillo Vis		
15	5100009323	1	Stator Stator	Estatore Stator		
16	0217812	1	Fixation Fixierung	Fijación Fixation		
20	0209002	1	Clamp Schelle	Abrazadera Collier		
21	0084156	1	Screw Schraube	Tornillo Vis		
22	0082140	1	Nut Mutter	Tuerca Écrou		
23	0159283	1	Flange Flansch	Brida Bride		
24	0215493	1	Hexagon nut Sechskantmutter	Tuerca hexagonal Écrou hexagonal		
25	0082288	1	Washer Scheibe	Arandela Rondelle		
26	0211380	1	Starter Anlasser	Arrancador Démarreur		
27	0206968	1	Flange Flansch	Brida Bride		
28	0083027	2	Screw Schraube	Tornillo Vis		
29	0159259	3	Cable Kabel	Cable Câble		
30	0155748	4	Glow plug Glühkerze	Tapón luminoso Bougie de préchauffage		
31	0160194	1	Wire-glow plug Glühkerzenkabel	Alambre para tapón encendedor Câble pour bougie de		
32	0209002	4	Clamp Schelle	Abrazadera Collier		
33	0209091	1	Plug cap Steckerkappe	Capa Chapeau		
34	0209090	1	Adapter Plug Zwischenstecker	Enchufe Intermedio Prise Intermédiaire		
35	5100009322	1	Cable Kabel	Cable Câble		

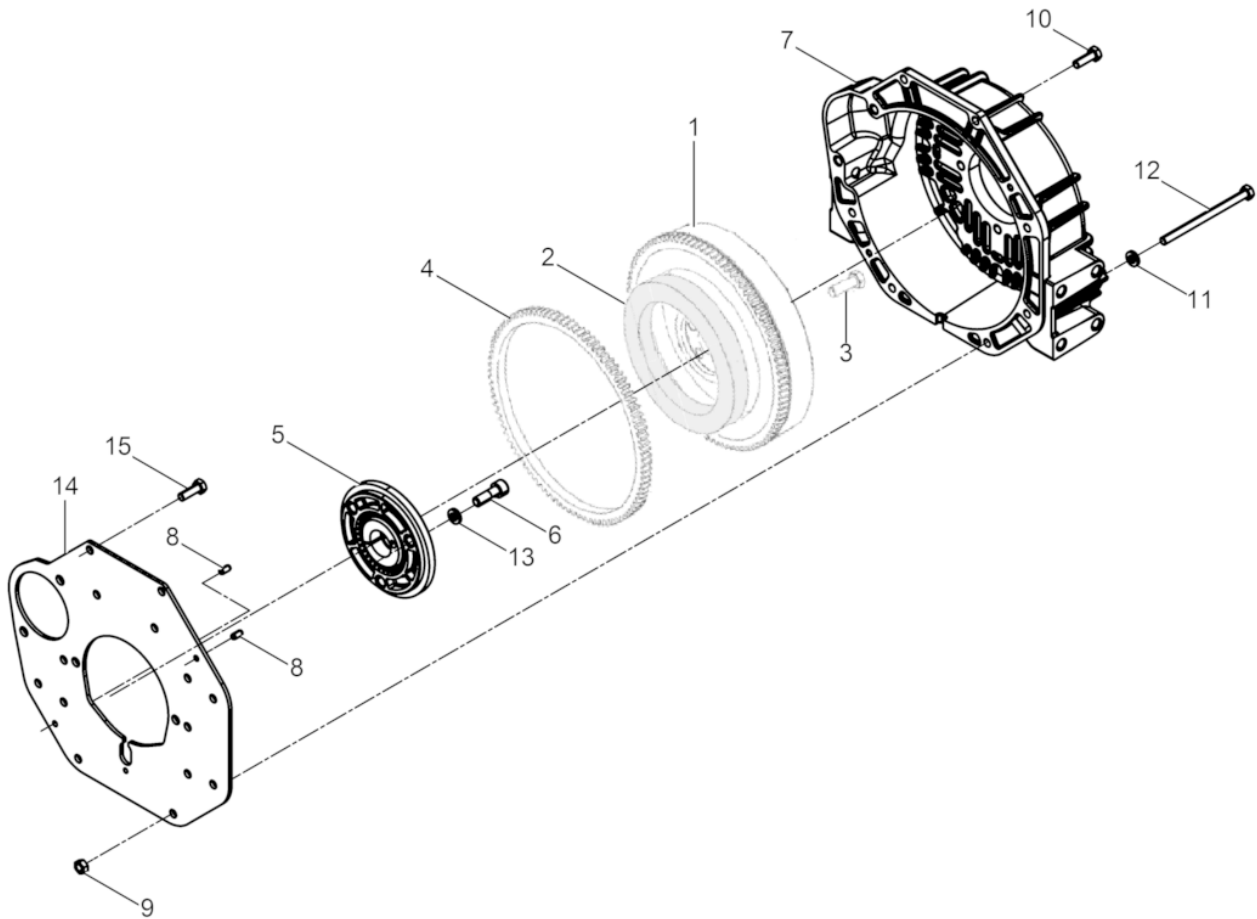

Ref. Pos.	Part No. Artikel Nr.	Qty. St.	Description Beschreibung	Descripción Description	Measurem./Abm.	Norm
					Torque/Drehm.	Sealant Schmierstoff
1	0159485	1	Flywheel compl. Schwungrad kpl.	Volante compl. Volant compl.		
1	0215545	1	Flywheel Schwungrad	Volante Volant		
2	0155693	1	Gear crown Zahnkranz	Borde de engranaje Jante d'engrenage		
3	0160188	5	Bolt Bolzen	Perno Boulon		
4	0159258	1	Rotor Rotor	Rotor Rotor		
5	0211373	1	Coupling cpl. Kupplung kpl.	Embrague cpl. Embrayage cpl.		
6	0084164	3	Screw Schraube	Tornillo Vis		
7	0217823	1	Coupling housing Anschlussgehäuse	Caja de conexión Carter de branchement		
8	0211370	2	Pin Stift	Espiga Goupille		
9	0082140	3	Nut Mutter	Tuerca Écrou		
10	0084123	3	Screw Schraube	Tornillo Vis		
11	0211371	4	Washer Scheibe	Disco Rondelle		
12	0211372	4	Screw Schraube	Tornillo Vis		
13	0160231	3	Washer Scheibe	Disco Rondelle		
14	0159326	1	Plate Platte	Placa Plaque		
15	0159254	7	Bolt Bolzen	Perno Boulon		



**WACKER
NEUSON**

**Service
Service
Servicio
Service**

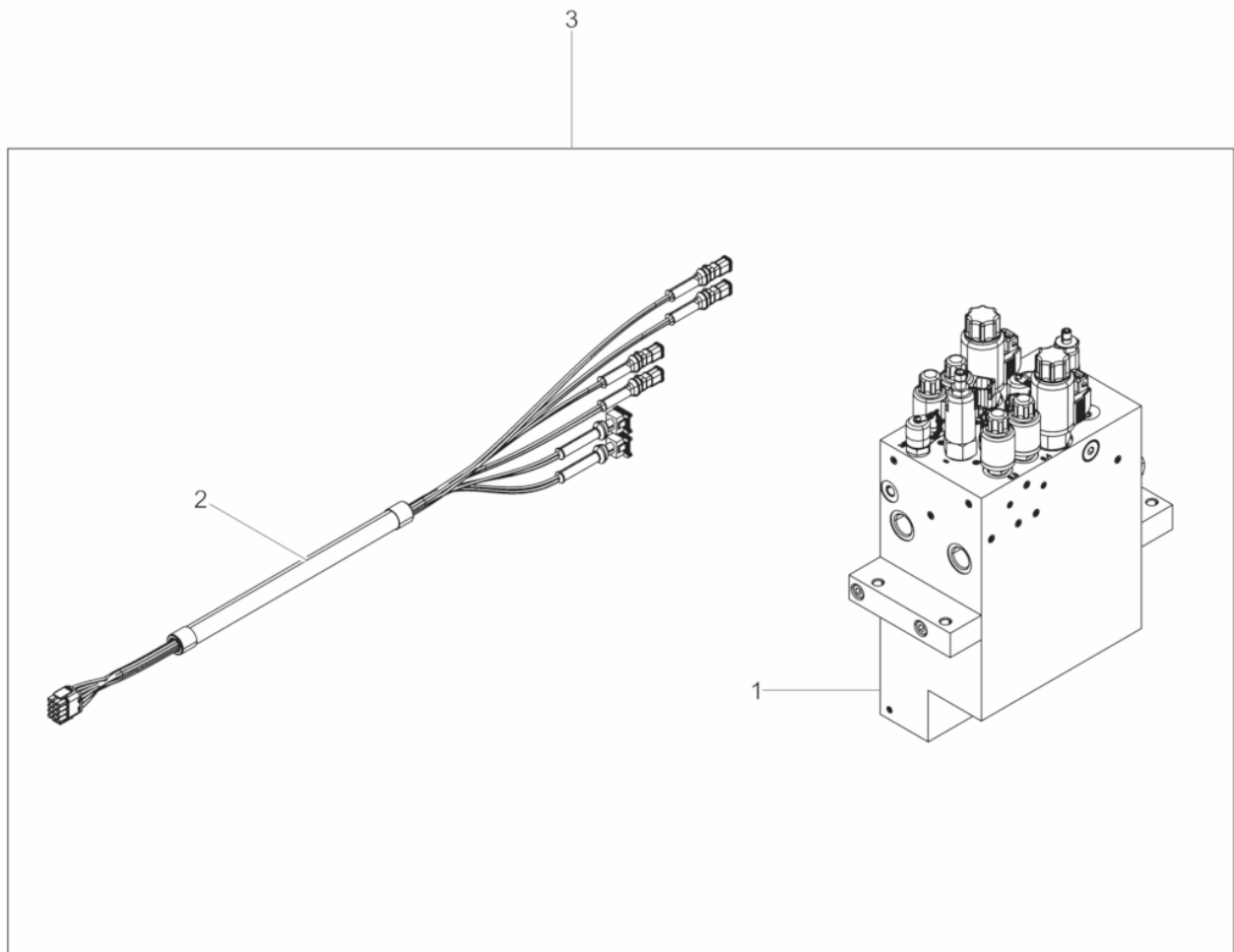

Ref. Pos.	Part No. Artikel Nr.	Qty. St.	Description Beschreibung	Descripción Description	Measurement./Abm.	Norm
					Torque/Drehm.	Sealant Schmierstoff
1	5100031274	1	Block-Hydraulic Hydraulikblock	Bloque Hidráulico Bloc Hydraulique		
2	5100031275	1	Cable harness Valve Kabelbaum Ventil	Disp. del cable de elevación Válvula Faisceau de câbles Soupape		
3	5100033299	1	Block-Hydraulic kit Hydraulikblock Satz	Bloque Hidráulico Juego Bloc Hydraulique Jeu		



**WACKER
NEUSON**