

The EDGE Smart Design

Pallet Trucks Family

PTE12N

- 1.2T Capacity **Li-ion**

- Perfect for light-duty applications
- Compact & skeleton design
- Fast-charging Li-ion batteries
- Ideal for occasional operations
- Easy-battery replacement
- High maneuverability

DC 24V



PTE15N

- 1.5T Capacity **Li-ion**

- Perfect for light-duty applications
- Compact & skeleton design
- Light service weight
- Fast-charging Li-ion batteries
- Ideal for use on retail stores, lorries
- Easy-battery replacement

DC 24V



PTE20N

- 2.0T Capacity **Li-ion**

- Ultimate solution for heavy loads move
- Compact & robust design
- Fast-charging Li-ion batteries
- Easy-battery replacement
- Great grade-ability performance
- Powerful drive & pump system

BLDC 48V



Smart and Ergonomic Tillers

The Edge series trucks are configured with control tillers adopted to meet with application needs based on trucks designated performance.

Standard For PTE12N

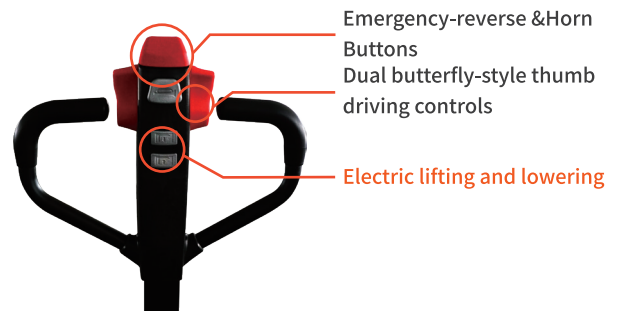

Standard For PTE15N , Optional PTE12N

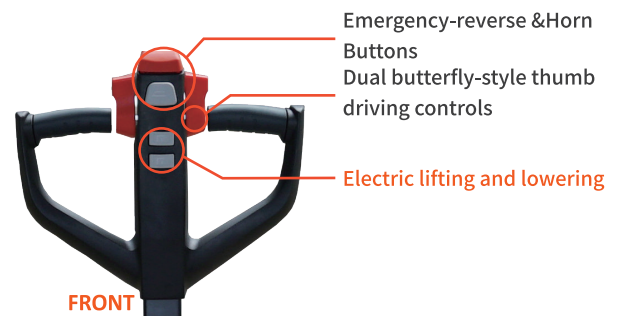
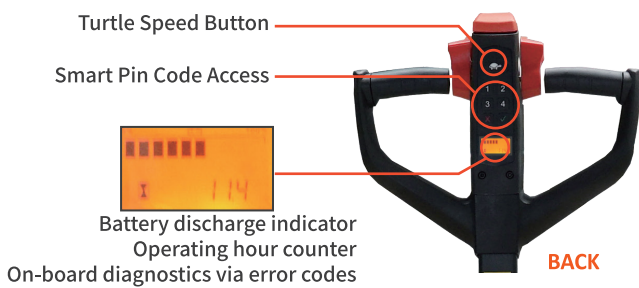

RFID Card Access is Standard for PTE20N optional for all other models

RFID card provides faster access to equipment and ideal for applications when one truck needs to be used by different operators.



The tiller bar is supported by the air spring which helps to return the tiller to its vertical position without strike in the end point.

For increase of operation comfort and safety the trucks are equipped with speed reduction function in turns. (Optional for PTE12N and PTE15N, standard for other trucks)

The value of speed reduction is adjustable according to customers' preferences .

Smart & Replaceable Batteries for Pallet Trucks

The ***PTE xxN trucks** are equipped with maintenance-free Li-ion batteries, optional capacities for various applications are available, with its fast charging and opportunity charging features (charge whenever you want and as long as time allows) the operation time can be extended significantly.

All pallet trucks batteries are located in battery compartments securely, any possibility of movement is excluded, therefore the reliability of power supply is ensured.

*: xx=Capacity

Light weight of the battery(max. 8kg) and the easiest way of fast battery replacement allows even a female operator to double the working time within seconds. The light weight of the batteries can be achieved through use of Li-ion battery type with high ratio of energy density to its self-weight.



All Li-ion batteries are equipped with on-board Battery Management System (BMS), which provides mandatory control of all important parameters of the battery during charging and operation. With this control, the safety of Li-ion battery during the whole life-cycle is guaranteed. The Li-ion batteries are certified according to international safety transportation (by sea and by air) and operation standards. The BMS communicates with control system of the truck via CAN, the support of the CAN protocols allows to monitor the condition of the battery and make its diagnosis with help of special software which is available for our partners.



Optional different battery capacities from 20Ah to 36Ah for various applications

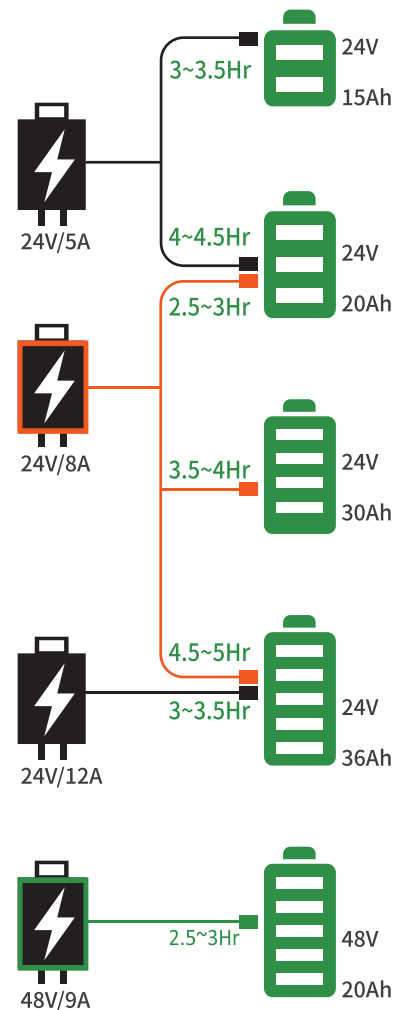

Manage your working time with selection of batteries and chargers



Socket on battery case for easy battery charging without necessity to take the battery out



The positioning of the battery inside the battery compartment is fast and easy thanks to specially designed battery guiding system



Battery cases for pallet trucks are made out of ABS PC material with **15%** of glass fiber.

The ***PTE xxN** trucks remains unpowered while charger is connected with the battery charging socket even if the charger is disconnected from the power outlet, therefore, the safety is ensured and the possibility to damage the charger is excluded.

*: xx=Capacity



The PTE 20B truck is equipped with maintenance-free AGM battery pack, the charging time is **8 hours**.

With the smart design, the battery pack can be replaced when it is necessary to double the operation time.

100% min. **2.5** hours charge | Excellent working time



Gradeability Performance & Robustness



The Edge series trucks have great performance on ramps even when they are fully loaded regardless their economic positioning, each truck based on its performance level can climb on sufficient level of ramp, therefore, every customer can select the truck with consideration of particular working environment.

Model	PTE12N	PTE15N	PTE20N
Max. grade ability laden	4%	6%	7%
Max. grade ability unladen	16%	16%	16%

The frame of truck is surrounded by stamped steel elements making the truck looking different and also ensuring the protection of components for PTE15N and PTE20N



Forks of the truck with shape for easy entrance and exit from pallets for PTE15N and PTE20N. Full length double sided C-shape reinforcements of forks significantly increase strength and rigidity of frame.

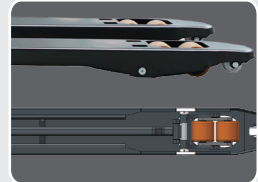

Strong steel apron protects the operator's feet during work and secures the truck's components from collisions with objects.





Maintenance Friendly

Drive motor with intelligent Curtis control



For the pallet trucks there are no hoses or pipes used in the hydraulic lifting circuit which significantly improves **reliability** and reduces the amount of potential problems related to leakages through connectors or their seals.

The trucks are equipped with **Curtis** controllers, **CAN-bus** technology makes the diagnostic and troubleshooting easier. **The use of proved and certified components helps to ensure the conformity to international safety standards with all the supporting documents available as required by law.**



Capacity

	Ready	Min Volt	Max Volt
	24.50V	0mV	0mV
	0.00A	Avg Volt	Communication
		0.0mV	Normal

Realtime

Rated Capacity	60.0	Ah	Wh(Current)	0.0	Wh	Reset
Discharge Cycle ...			Discharge Cycle ...			
Times			Times			

Other

Name	Value	Units
Cell Temp1	25.3	°C
Cell Temp1	25.1	°C
SOC	45	1/255
Power Temp	27.1	°C
Envir Temp	32.2	°C
Cell Volt Alarm	none	
Total Volt Alarm	none	
Current Alarm	none	
Temp Alarm	none	
Balance Alarm	none	

Volt

Name	Value	Units
Cell	3507	mV
Total	24.5	V
Current	0.0	A
Run(Wh)	0	Wh

Each battery can be diagnosed via CAN connection with help of special software tool, the software can provide information about the battery condition such as balance of cells, amount of charging/discharging cycles, current, energy consumption, temperature, charging/discharging parameters, voltage of every cell, faults and alarms, settings of timing for automatic turn off.

STANDARD CONFIGURATION OR OPTIONS

	PTE12N	PTE15N	PTE20N
Standard Battery	Li-ion 24V/20Ah	Li-ion 24V/20Ah	Li-ion 48V/20Ah
Li-ion Battery 24V/20Ah	O	S	—
Li-ion Battery 24V/30Ah	O	O	—
Li-ion Battery 24V/36Ah	O	O	—
AGM 2x12V/106Ah (5 Hr)	—	—	—
Standard Charger	24V/5A	24V/5A	48V/9A
Li-ion Charger 24V/5A	S	S	—
Li-ion Charger 24V/8A	with optional battery only	O	—
Li-ion Charger 24V/12A	with 36Ah battery only	with 36Ah battery only	—
BMS	S	S	—
CAN-communication	S	S	S
Speed Reduction at Turning	O	O	S
Vertical drive/Pin wheel	S	S	S
Fast battery replacement	S	S	S
Entry Roller	S	S	S
Single Fork Roller	S	S	S
Tandem Fork Rollers	O	O	O
On-board charger	—	—	—
Stability Castors	O	O	S
High traction drive wheel tyre	O	O	—
Fork length 800/900/1000mm	O	O	O
Fork width 370/550/570mm	—	O	—
Load backrest(42/48/60°)	—	O	O
Pin Code Access	O	S	S
RFID Access	O	O	S
LED Indicators on Tiller	S	—	—
LCD Display on Tiller	O	O	S

S=Standard

O=Optional

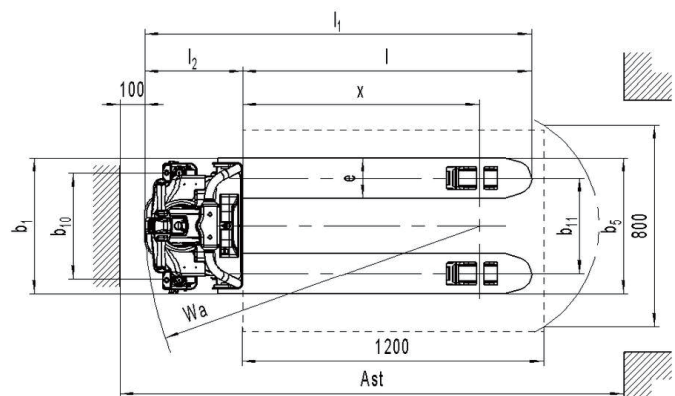
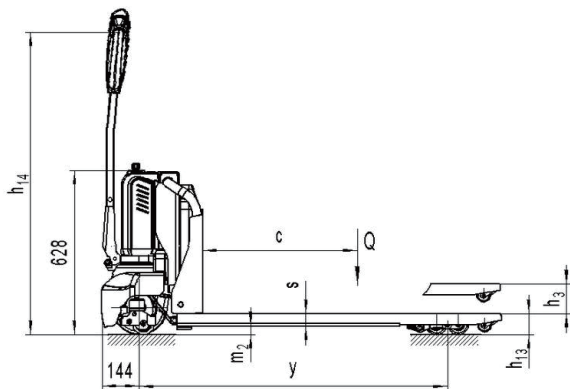

Type sheet for industrial truck acc. to VDI 2198 1KG=2.2LB 1INCH=25.4MM

Identification

1.2	Manufacturer's type designation		PTE12N
1.3	Drive		Battery
1.4	Operator type		Pedestrian
1.5	Load Capacity / rated load	Q (t)	1.2
1.6	Load centre distance	c (mm)	600
1.8	Load distance ,centre of drive axle to fork	x (mm)	942
1.9	Wheelbase	y (mm)	1185

Weights

2.1	Service weight	kg	124	129
2.2	Axle loading, laden front/rear	kg	355 / 969	425 / 904
2.3	Axle loading, unladen front/rear	kg	92 / 27	102 / 27

Wheels, Chassis

3.1	Tires		Polyurethane (PU)	
3.2	Tire size,front	Øx w (mm)	Ø210×75	
3.3	Tire size,rear	Øx w (mm)	Ø80×93(Ø80×70)	
3.4	Additional wheels(dimensions)	Øx w (mm)	Ø- 80×30	
3.5	Wheels,number front/rear(x=driven wheels)		1x/ 2(1x/ 4) or 1x +2/ 2(1x +2/ 4)	
3.6	Tread, front	b10 (mm)	-/430	
3.7	Tread, rear	b11 (mm)	380	525

Basic Dimensions

4.4	Lift	h3 (mm)	115	
4.9	Height of tiller in drive position min./ max.	h14 (mm)	700 / 1160	
4.15	Height, lowered	h13 (mm)	80	
4.19	Overall length	l1 (mm)	1537	
4.20	Length to face of forks	l2 (mm)	387	
4.21	Overall width	b1 (mm)	540	685
4.22	Fork dimensions	s/e/l (mm)	48 / 160 / 1150	
4.25	Width across forks	b5 (mm)	540	685
4.32	Ground clearance, centre of wheelbase	m2 (mm)	32	
4.34	Aisle width for pallets800X1200 lengthways(200mm safe distance)	Ast (mm)	2007	
4.35	Turning radius	Wa (mm)	1337	

Performance Data

5.1	Travel speed, laden/ unladen	km/h	4.6/ 4.8	
5.2	Lift speed, laden/ unladen	m/s	0.031 / 0.037	
5.3	Lowering speed, laden/ unladen	m/s	0.069 / 0.051	
5.8	Max. gradeability, laden/ unladen	%	6 / 16	
5.10	Service brake		Electromagnetic	

E-Motor

6.1	Drive motor rating S2 60min	kW	0.65	
6.2	Lift motor rating at S3 10%	kW	0.50	
6.3	Battery acc. to DIN 43531/ 35/ 36 A, B, C, no		No	
6.4	Battery voltage, nominal capacity K5	V / Ah	24/20 (24/36)	
6.5	Battery weight	kg	5.5	
6.6	Energy consumption acc. to VDI cycle	kWh/h	0.14	

Other Details

8.1	Type of drive control		DC speed Control	
8.4	Sound level at driver's ear acc. to EN 12053	dB(A)	<70	

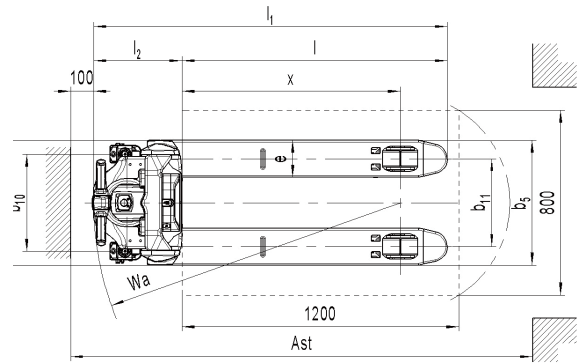
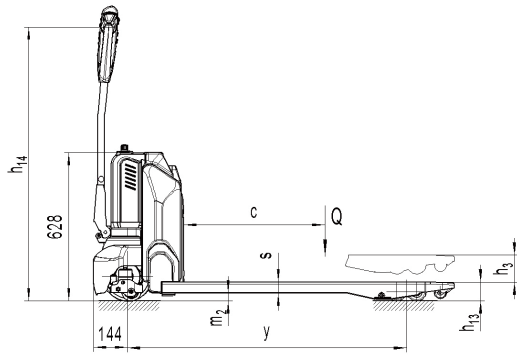

Type sheet for industrial truck acc. to VDI 2198 1KG=2.2LB 1INCH=25.4MM

Identification

1.2	Manufacturer's type designation		PTE15N
1.3	Drive		Battery
1.4	Operator type		Pedestrian
1.5	Load Capacity / rated load	Q (t)	1.5
1.6	Load centre distance	c (mm)	600
1.8	Load distance ,centre of drive axle to fork	x (mm)	947
1.9	Wheelbase	y (mm)	1185

Weights

2.1	Service weight	kg	136	139
2.2	Axle loading, laden front/rear	kg	636/1000	626/1000
2.3	Axle loading, unladen front/rear	kg	107/27	99/27

Wheels, Chassis

3.1	Tires		Polyurethane (PU)	
3.2	Tire size,front	Øx w (mm)	Ø210×75	
3.3	Tire size,rear	Øx w (mm)	Ø80×93(Ø80×70)	
3.4	Additional wheels(dimensions)	Øx w (mm)	Ø80×30	
3.5	Wheels,number front/rear(x=driven wheels)		1x/ 2(1x/ 4) or 1x +2/ 2(1x +2/ 4)	
3.6	Tread, front	b10 (mm)	430	
3.7	Tread, rear	b11 (mm)	380	525

Basic Dimensions

4.4	Lift	h3 (mm)	115	
4.9	Height of tiller in drive position min./ max.	h14 (mm)	700 / 1160	
4.15	Height, lowered	h13 (mm)	80	
4.19	Overall length	l1 (mm)	1530	
4.20	Length to face of forks	l2 (mm)	380	
4.21	Overall width	b1 (mm)	540	685
4.22	Fork dimensions	s/e/l (mm)	47 / 160 / 1150	
4.25	Width across forks	b5 (mm)	540	685
4.32	Ground clearance, centre of wheelbase	m2 (mm)	33	
4.34	Aisle width for pallets800X1200 lengthways(200mm safe distance)	Ast (mm)	2000	
4.35	Turning radius	Wa (mm)	1330	

Performance Data

5.1	Travel speed, laden/ unladen	km/h	4.6/4.8	
5.2	Lift speed, laden/ unladen	m/s	0.020/0.025	
5.3	Lowering speed, laden/ unladen	m/s	0.05 / 0.04	
5.8	Max. gradeability, laden/ unladen	%	6 / 16	
5.10	Service brake		Electromagnetic	

E-Motor

6.1	Drive motor rating S2 60min	kW	0.65	
6.2	Lift motor rating at S3 10%	kW	0.50	
6.3	Battery acc. to DIN 43531/ 35/ 36 A, B, C, no		/	
6.4	Battery voltage, nominal capacity K5	V / Ah	24/20 (24/36)	
6.5	Battery weight	kg	5.5	
6.6	Energy consumption acc. to VDI cycle	kWh/h	0.18	

Other Details

8.1	Type of drive control		DC speed Control	
8.4	Sound level at driver's ear acc. to EN 12053	dB(A)	<70	

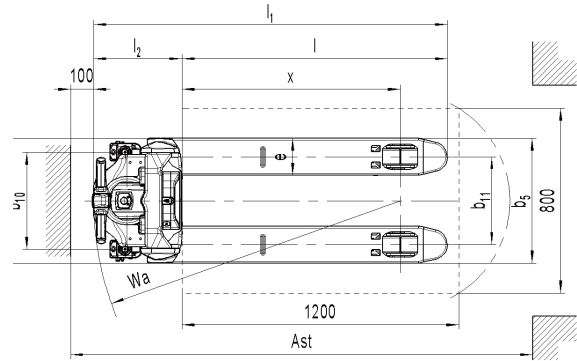
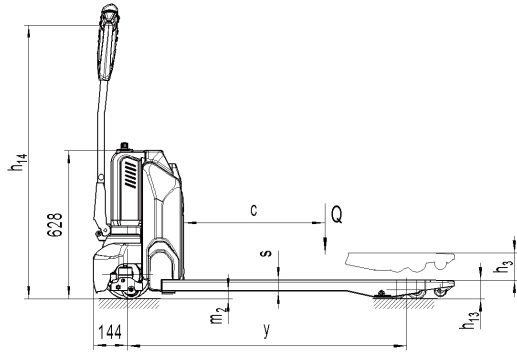

Type sheet for industrial truck acc. to VDI 2198 1KG=2.2LB 1INCH=25.4MM

Identification

1.2	Manufacturer's type designation		PTE20N
1.3	Drive		Battery
1.4	Operator type		Pedestrian
1.5	Load Capacity / rated load	Q (t)	2.0
1.6	Load centre distance	c (mm)	600
1.8	Load distance ,centre of drive axle to fork	x (mm)	951
1.9	Wheelbase	y (mm)	1189

Weights

2.1	Service weight	kg	149	153
2.2	Axle loading, laden front/rear	kg	621/1528	625/1528
2.3	Axle loading, unladen front/rear	kg	115/34	119/34

Wheels, Chassis

3.1	Tires		Polyurethane (PU)	
3.2	Tire size,front	Øx w (mm)	Ø210×75	
3.3	Tire size,rear	Øx w (mm)	Ø80×93(Ø80×70)	
3.4	Additional wheels(dimensions)	Øx w (mm)	Ø80×30	
3.5	Wheels,number front/rear(x=driven wheels)		1x/ 2(1x/ 4) or 1x +2/ 2(1x +2/ 4)	
3.6	Tread, front	b10 (mm)	430	
3.7	Tread, rear	b11 (mm)	380	525

Basic Dimensions

4.4	Lift	h3 (mm)	115	
4.9	Height of tiller in drive position min./ max.	h14 (mm)	700 / 1160	
4.15	Height, lowered	h13 (mm)	80	
4.19	Overall length	l1 (mm)	1536	
4.20	Length to face of forks	l2 (mm)	386	
4.21	Overall width	b1 (mm)	540	685
4.22	Fork dimensions	s/e/l (mm)	47 / 160 / 1150	
4.25	Width across forks	b5 (mm)	540	685
4.32	Ground clearance, centre of wheelbase	m2 (mm)	33	
4.34	Aisle width for pallets800X1200 lengthways(200mm safe distance)	Ast (mm)	2006	
4.35	Turning radius	Wa (mm)	1336	

Performance Data

5.1	Travel speed, laden/ unladen	km/h	4.8/5.2	
5.2	Lift speed, laden/ unladen	m/s	0.017/0.022	
5.3	Lowering speed, laden/ unladen	m/s	0.05/0.03	
5.8	Max. gradeability, laden/ unladen	%	7 / 16	
5.10	Service brake		Electromagnetic	

E-Motor

6.1	Drive motor rating S2 60min	kW	0.75	
6.2	Lift motor rating at S3 10%	kW	0.8	
6.3	Battery acc. to DIN 43531/ 35/ 36 A, B, C, no		/	
6.4	Battery voltage, nominal capacity K5	V / Ah	48/20	
6.5	Battery weight	kg	7.7	
6.6	Energy consumption acc. to VDI cycle	kWh/h	0.23	

Other Details

8.1	Type of drive control		DC speed Control	
8.4	Sound level at driver's ear acc. to EN 12053	dB(A)	<70	