

# PS 15 / PS 15SL

## The Electric Walkie Pallet Truck

### PS 15 Narrow type



### INTRODUCTION

The PS15-Series ensures with high performance through AC drive technology in intensive stacking operations with capacities up to 3300lbs(1500kg) with 2- and 3-stage masts.

The optional available foldable platform is the best choice if the truck is used in larger warehouse with longer travelling distances.

### ADVANTAGES

- High capacity of 3300lbs(1500kg).
- Noblelift AC drive system.
- Electric steering (optional).
- Robust 2- and 3stage masts for lift heights up to 6000mm lift height.
- Foldable platform and protective arms (optional).



Key-switch, emergency switch and battery discharge indicator.

### PS 15SL Straddle-leg type



**Tiller**  
All operating elements on the CAN tiller are easy to reach.

**Noblelift AC drive system**  
The AC drive system gives high performance, ensures low maintenance costs and its high efficiency, saves energy for longer operations.

**Optional straddle leg**  
Adjustable straddle leg design, suitable for diverse pallet sizes and more stability.



**Standard battery**  
Long operating time through high capacity with 3 PZS battery.



**Storage tray**  
The robust battery cover to with storage areas for utilities or packaging and stretch foil.

**Electric steering (optional)**  
The electric steering makes the operating effortless. Maneuvering in narrow spaces becomes with the electric steering easiest.

**Different mast versions**  
2- stage and 3-stage masts up to 236inch lift-height.



**Optional foldable platform**  
Optional suspension foldable platform with sideways protective arms. The ergonomically designed foldable platform in combination with its sideways protective arms makes operations faster and safer.

### Mast table PS 15

Designation	Lowered mast height h1 (mm)	Free lift height h2 (mm)	Lift height h3 (mm)	Extended mast height h4 (mm)	Lift+fork height h3+h13 (mm)
<b>PS 15</b>					
<b>Two-stage mast</b>	1950	150	2815	3370	2900
	2100	150	3115	3670	3200
	2300	150	3515	4070	3600
	2500	150	3915	4470	4000
<b>Two-stage mast FFL (Full-Free-Lift)</b>	1950	1480	2815	3370	2900
	2300	1830	3515	4070	3600
<b>Three-stage mast FFL (Full-Free-Lift)</b>	1980	1420	4215	4865	4300
	2080	1520	4515	5115	4600
	2220	1660	4915	5520	5000
	2475	1875	5415	6060	5500
	2740	2100	5915	6600	6000

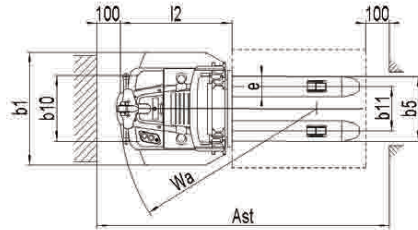
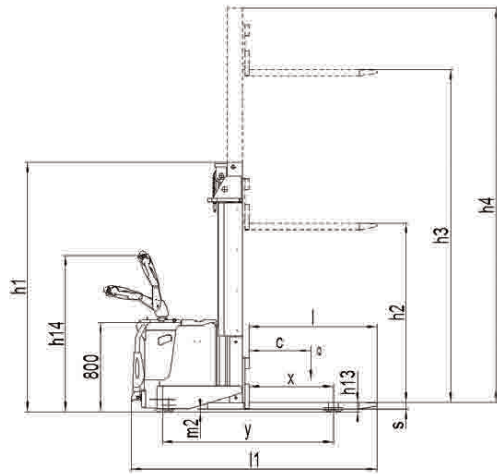

### PS 15 Type sheet for industrial truck acc. to VDI 2198 1KG=2.2LB 1INCH=25.4MM

<b>Distinguishing mark</b>	1.2	Manufacturer's type designation	<b>PS 15</b>		
	1.3	Power (battery, diesel, petrol, gas, manual)	5000	2900	
	1.4	Operator type	Battery Pedestrian		
	1.5	Load Capacity / rated load	1.5		
	1.6	Load centre distance	Q (t)	600	
<b>Weight</b>	1.8	Load distance, centre of drive axle to fork	C (mm)	600	
	1.9	Wheelbase	X (mm)	751	755
	2.1	Service weight	Y (mm)	1526	1407
	2.2	Axle loading, laden front/rear	kg	1596	1095
	2.3	Axle loading, unladen front/rear	kg	1345/1663	1165/1430
<b>Tyres, chassis</b>	2.3	Axle loading, unladen front/rear	kg	955/553	735/360
	3.1	Tires	Polyurethane (PU)		
	3.2	Tire size, front	Ø x w (mm)	Ø230×75	
	3.3	Tire size, rear	Ø x w (mm)	Ø 80× 70	
	3.4	Additional wheels(dimensions)	Ø x w (mm)	Ø124×60	
	3.5	Wheels, number front/rear(x=driven wheels)		1x+2/4	
	3.6	Tread, front	b10 (mm)	766	570
3.7	Tread, rear	b11 (mm)	380/505		
<b>Dimensions</b>	4.2	Lowered mast height	h1 (mm)	2220	1950
	4.3	Free lift height	h2 (mm)	1660	150
	4.4	Lift	h3 (mm)	4915	2815
	4.5	Extended mast height	h4 (mm)	5520	3370
	4.9	Height of tiller in drive position min./max.	h14 (mm)	1370/945	
	4.15	Height, lowered	h13 (mm)	85	
	4.19	Overall length	l1 (mm)	2110 <sup>1)</sup>	1987 <sup>1)</sup>
	4.20	Length to face of forks	l2 (mm)	960 <sup>1)</sup>	837 <sup>1)</sup>
	4.21	Overall width	b1 (mm)	1000	795
	4.22	Fork dimensions	s/e/l (mm)	60/180/1150	
	4.25	Distance between fork-arms	b5 (mm)	570/685 <sup>3)</sup>	
	4.32	Ground clearance, centre of wheelbase	m2 (mm)	25	
	4.33	Aisle width for pallets 1000X1200 lengthways	Ast (mm)	2567 <sup>1)</sup>	2447 <sup>1)</sup>
	4.34	Aisle width for pallets 800X1200 lengthways	Ast (mm)	2519 <sup>1)</sup>	2397 <sup>1)</sup>
	4.35	Turning radius	Wa (mm)	1717 <sup>1)</sup>	1598 <sup>1)</sup>
<b>Performance data</b>	5.1	Travel speed, laden/unladen	Km/h	6.0/6.0	
	5.2	Lift speed, laden/ unladen	m/s	0.14/0.212	0.082/0.152 <sup>2)</sup>
	5.3	Lowering speed, laden/ unladen	m/s	0.196/0.178	0.108/0.095 <sup>2)</sup>
	5.8	Max. gradeability performance, laden/ unladen	%	6/12	
	5.10	Service brake		Electromagnetic	
<b>Electric- engine</b>	6.1	Drive motor rating S2 60min	kW	1.3	
	6.2	Lift motor rating at S3 15%	kW	3.0	2.2 <sup>2)</sup>
	6.3	Battery acc. to DIN 43531/35/36 A, B, C, no		B,3P2S	B,2P2S
	6.4	Battery voltage, nominal capacity KS	V/Ah	24/350	24/210
	6.5	Battery weight	kg	288	217
	6.6	Energy consumption acc. to VDI cycle	kWh/h	2.36	
<b>Additional data</b>	8.1	Type of drive control		AC- Speed Control	
	8.4	Sound level at driver's ear according to EN 12053	dB(A)	69	

Electric Stackler

1)With foldable platform the following dimensions increase: l1+83mm/ l2+83mm/Wa+93mm/Ast+93mm.

2)For two-stage mast truck with lifting height 2900mm, other two-stage mast truck (仅对于提升2900mm的二门架车型, 其余二门架车型): Lift speed-laden/ unladen=0.150/0.226m/s, Lowering speed-laden/ unladen=0.168/0.155 m/s, Lift motor=3.0kw.

3)6000 height only has 685 specification.

### Mast table PS 15SL

Designation	Lowered mast height h1 (mm)	Free lift height h2 (mm)	Lift height h3 (mm)	Extended mast height h4 (mm)	Lift+fork height h3+h13 (mm)
<b>PS 15SL</b>					
<b>Two-stage mast</b>	1950	150	2850	3370	2900
	2100	150	3150	3670	3200
	2300	150	3550	4070	3600
	2500	150	3950	4470	4000
<b>Two-stage mast FFL (Full-Free-Lift)</b>	1950	1480	2850	3370	2900
	2300	1830	3550	4070	3600
<b>Three-stage mast FFL (Full-Free-Lift)</b>	1980	1420	4250	4865	4300
	2080	1520	4550	5115	4600
	2220	1660	4950	5520	5000
	2475	1875	5450	6060	5500
	2740	2100	5950	6600	6000

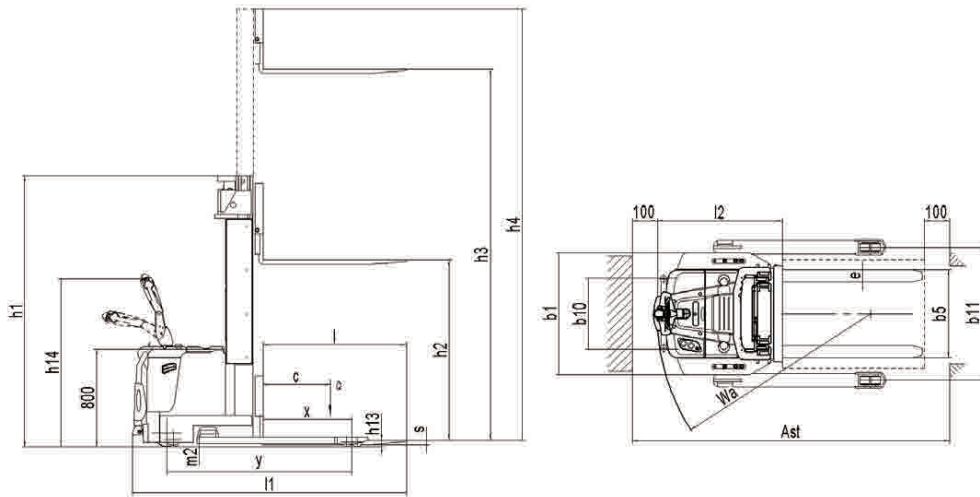

### PS 15SL Type sheet for industrial truck acc. to VDI 2198 1KG=2.2LB 1INCH=25.4MM

<b>Distinguishing mark</b>	1.2	Manufacturer's type designation	5000	PS 15SL	2900	
	1.3	Power (battery ,diesel ,petrol, gas, manual)		Battery		
	1.4	Operator type		Pedestrian		
	1.5	Load Capacity / rated load	Q (t)	1.5		
	1.6	Load centre distance	C (mm)	600		
	1.8	Load distance ,centre of drive axle to fork	X (mm)	722	710	
	1.9	Wheelbase	Y (mm)	1527	1393	
	<b>Weight</b>	2.1	Service weight	kg	1702	1270
		2.2	Axle loading, laden front/rear	kg	1399/1716	1250/1520
2.3		Axle loading, unladen front/rear	kg	1008/606	825/445	
<b>Tyres, chassis</b>	3.1	Tyres		Polyurethane (PU)		
	3.2	Tire size, front	Ø x w (mm)	Ø230×75		
	3.3	Tire size, rear	Ø x w (mm)	Ø80×70		
	3.4	Additional wheels(dimensions)	Ø x w (mm)	Ø124×60		
	3.5	Wheels, number front/rear(x=driven wheels)		1x+2/4		
	3.6	Track, front	b10 (mm)	766	570	
	3.7	Track, rear	b11 (mm)	1088-1388		
<b>Dimensions</b>	4.2	Lowered mast height	h1 (mm)	2220	1950	
	4.3	Free Lift height	h2 (mm)	1660	150	
	4.4	Lift height	h3 (mm)	4950	2850	
	4.5	Extended mast height	h4 (mm)	5520	3370	
	4.9	Height of filler in drive position min / max	h14 (mm)	1370/945		
	4.15	Height, lowered t	h13 (mm)	50		
	4.19	Overall length	l1 (mm)	2140 <sup>1)</sup>	2019 <sup>1)</sup>	
	4.20	Length to face of forks	l2 (mm)	990 <sup>1)</sup>	869 <sup>1)</sup>	
	4.21	Overall width	b1 (mm)	1000	796	
	4.22	Fork dimensions	s/e/l (mm)	35/100/1150		
	4.25	Distance between fork-arms	b5 (mm)	200-720		
	4.32	Ground clearance, centre of wheelbase	m2 (mm)	25		
	4.33	Aisle width for pallets 1000X1200 crossways	Ast (mm)	2580 <sup>1)</sup>	2580 <sup>1)</sup>	
4.34	Aisle width for pallets 800X1200 lengthways	Ast (mm)	2542 <sup>1)</sup>	2418 <sup>1)</sup>		
4.35	Turning radius	Va (mm)	1718 <sup>1)</sup>	1585 <sup>1)</sup>		
<b>Performance data</b>	5.1	Travel speed, laden/ unladen	km/h	6.0/6.0		
	5.2	Lift speed, laden/ unladen	m/s	0.141/0.212	0.082/0.152 <sup>2)</sup>	
	5.3	Lowering speed, laden/ unladen	m/s	0.196/0.178	0.108/0.095 <sup>2)</sup>	
	5.8	Max. gradeability, laden/ unladen	%	6/12		
	5.10	Service brake		Electromagnetic		
<b>Electric- engine</b>	6.1	Drive motor rating S2 60min	kw	1.3		
	6.2	Lift motor rating at S3 4.5%	kw	3.0	2.2 <sup>2)</sup>	
	6.3	Battery acc. to DIN 43531/35/36 A, B, C, no		B, 3PzS	B, 2PzS	
	6.4	Battery voltage, nominal capacity K5	V/Ah	24/350	24/210	
	6.5	Battery weight	kg	288	217	
	6.6	Energy consumption acc. to VDI cycle	kWh/h	2.36		
<b>Additional data</b>	8.1	Type of drive control		AC-Speed Control		
	8.4	Sound level at driver's ear acc. to EN 12053	dB(A)	69		

1)With foldable platform the following dimensions increase: l1+83mm/l2+83mm/Wa+93mm/Ast+93mm.

2)For two-stage mast truck with lifting height 2900mm, other two-stage mast truck(仅对于实际2900mm的二门车型, 其余二门车型):

Lift speed-laden/ unladen=0.150/0.226m/s, Lowering speed-laden/ unladen=0.168/0.155 m/s, Lift motor=3.0kw.