

PS13/15RM PLUS

The Most Versatile Stacker

INTRODUCTION

Compact structure with excellent forward function, vehicles in a narrow space can be used.

High-performance AC drive system, combined with electric steering unit to enhance whole vehicle's performance and efficiency. With high-quality components, excellent cost performance.

**Faster + High efficiency with German motor!
Upgraded speed of 8km/h for Ride-on Mode**

IT the vehicle is used in warehousing long distance transporting, optionally foldable pedal is the best choice.



Optional lithium battery configuration

8km/h

ADVANTAGES:

- Straddle leg design
- Forward function
- AC drive system
- Operator' Working will be easier with Electric Steering technology.
- The large battery capacity extends long time operation needs.
- Optional sideshift function.
- Optional side-pull battery.
- Optional pedal, protective arm, ergonomically foldable pedal.



Reach mast

In comparison with common counterbalance heavy stacker, PS13/15RM PLUS not only have same stability, but also have flexible.

Fork tilting

Tilting fork makes the pallet stacking work easier and safer, and separate.



Optional sideshift function

The optional sideshift function allows the forks to move, especially for small space, cargo can be accurately placed on the shelf.

Straddle leg

Direct entry of 800x1220mm pallet with upgraded design of the straddle 880mm inner width.



Mast table PS13/15RMPLUS

Designation	Lowered mast height h1 (mm)	Free lift height h2 (mm)	Lift height h3 (mm)	Extended mast height h4 (mm)
Single-stage mast	1796	1200	1200	2085
	2196	1600	1600	2485
Two-stage mast	2396	1800	1800	2685
	1796	-	2400	3285
Three-stage mast FFL	2096	-	3000	3885
	1796	1200	3600	4485
	2096	1500	4500	5385
	2196	1600	4800	5685

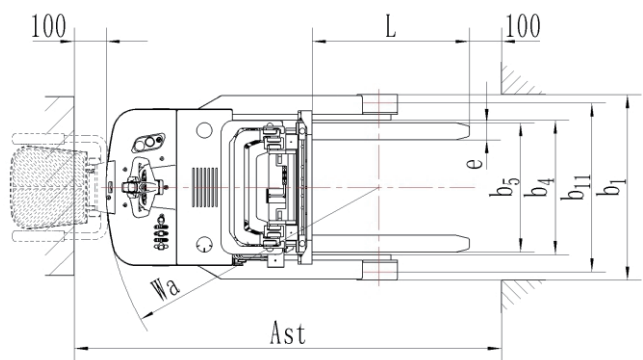
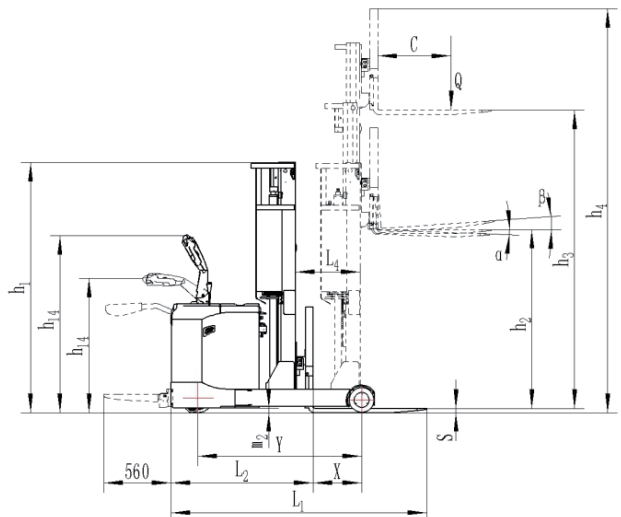

Type sheet for industrial truck acc. to VDI 2198 1KG=2.2LB 1INCH=25.4MM

Identification							
1.2	Manufacturer's type designation		PS13RMPLUS			PS15RMPLUS	
1.3	Drive		Battery			Battery	
1.4	Operator type		Pedestrian			Pedestrian	
1.5	Load Capacity / rated load	Q (t)	1.3			1.5	
1.6	Load centre distance	c (mm)	600			600	
1.8	Load distance ,centre of drive axle to fork	x (mm)	415			485	
1.9	Wheelbase	y (mm)	1350			1500	
Weights							
2.1	Service weight	kg	1750	1900	2200	1800	1950 2250
Wheels, Chassis							
3.1	Tires		Polyurethane (PU)			Polyurethane (PU)	
3.2	Tire size,front	Øx w (mm)	Ø 250 ×82			Ø 250 ×82	
3.3	Tire size,rear	Øx w (mm)	Ø 210×85			Ø 230×100	
3.4	Steering wheel size	Øx w (mm)	Ø 124×60			Ø 124×60	
3.5	Wheels,number front/rear(x=driven wheels)		1x+2/2			1x+2/2	
3.6	Tread, front	b10 (mm)	680			680	
3.7	Tread, rear	b11 (mm)	1085			1085	
Basic Dimensions							
4.1	Tilt of mast/fork carriage forward/backward	α/β(°)	2/4			2/4	
4.2	Lowered mast height	h1(mm)	2196	2096	2196	2196	2096 2196
4.3	Free Lift height	h2(mm)	1600	—	1600	1600	— 1600
4.4	Lift	h3(mm)	1600	3000	4800	1600	3000 4800
4.5	Extended maximal height	h4(mm)	2485	3885	5685	2485	3885 5685
4.9	Height of tiller in drive position min./ max.	h14 (mm)	1030/1415			1030/1415	
4.15	Height, lowered	h13 (mm)	50			50	
4.19	Overall length	l1 (mm)	2080 ¹⁾			2160 ¹⁾	
4.20	Length to face of forks	l2 (mm)	1160 ¹⁾			1240 ¹⁾	
4.21	Overall width	b1 (mm)	1184			1184	
4.22	Fork dimensions	s/e/l (mm)	35/100/920(1070)			35/100/920(1070)	
4.25	Width across forks	b5 (mm)	220-760			220-760	
4.26	Distance between supporting arm and load side	b4 (mm)	880			880	
4.28	Reach distance	l4 (mm)	545			630	
4.32	Ground clearance, centre of wheelbase	m2 (mm)	40			40	
4.33	Aisle width for pallets1000X1200 crossways	Ast (mm)	2600 ¹⁾			2710 ¹⁾	
4.34	Aisle width for pallets800X1200 lengthways	Ast (mm)	2650 ¹⁾			2740 ¹⁾	
4.35	Turning radius	Wa (mm)	1570 ¹⁾			1720 ¹⁾	
Performance Data							
5.1	Travel speed, laden/ unladen	km/h	5.5/6.0-8.0/8.0			5.5/6.0-8.0/8.0	
5.2	Lift speed, laden/ unladen	m/s	0.085/0.122		0.11/0.165		0.11/0.165
5.3	Lowering speed, laden/ unladen	m/s	0.125/0.08		0.11/0.10		0.11/0.10
5.8	Max. gradeability, laden/ unladen	%	5/8			5/8	
5.10	Service brake		Electromagnetic			Electromagnetic	
E-Motor							
6.1	Drive motor rating S2 60min	kW	2.6			2.6	
6.2	Lift motor rating at S3 10%	kW	2.2		3.0		3.0
6.3	Battery acc. to DIN 43531/ 35/ 36 A, B, C, no		3PzS		4PzS		3PzS 4PzS
6.4	Battery voltage, nominal capacity K5	V / Ah	24 / 270		24 / 400		24 / 270 24 / 400
Other Details							
8.1	Type of drive control		AC-Speed Control			AC-Speed Control	
8.4	Sound level at driver's ear acc. to EN 12053	dB(A)	67			67	

1) with foldable platform the following dimensions increase: l1, l2 =+100,Wa/Ast=+100.

This reference book is for internal training only and is not for commercial use. Relevant data are subject to change without notice