

271198501001驱动转向系统(FE3R12)/Drive steering system (FE3R12)

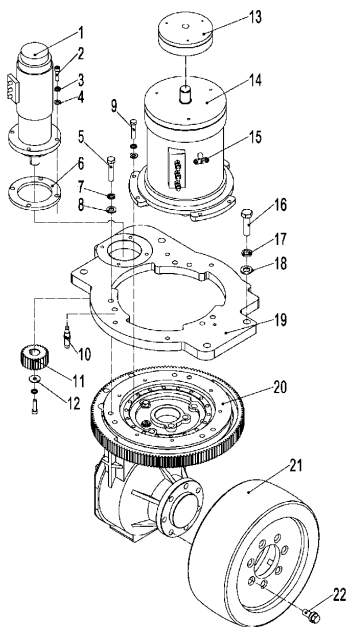

序号/NO	编码/SN	Name	名称	数量/QTY	备注/Remark
1	920900100050	Motor (DC)	电机(直流)	1	
2	910200200062	Screw GB70.1 M8x45-8.8	螺钉GB70.1-M8x45-8.8	4	
3	910400500006	Spring washer GB93-8	弹簧垫圈GB93-8	11	
4	910400100006	The flat washer GB97.1-8-200 HV	平垫圈GB97.1-8-200HV	10	
5	910100300055	Bolt GB5783 M12x55-8.8	螺栓GB5783-M12x55-8.8	6	
6	271514021002	Pad (steering motor)	垫块 (转向电机)	1	
7	910400500008	Spring washer GB93-12	弹簧垫圈GB93-12	2	
8	910400100008	The flat washer GB97.1-12-200 HV	平垫圈GB97.1-12-200HV	1	
9	910200200059	Screw GB70.1 M8x30-8.8	螺钉GB70.1-M8x30-8.8	7	
10	920200400011	Approach switch fi4-m12-on6l-I70	接近开关Fi4-G12-ON6L	1	
11	271514020005	Steering pinion	转向小齿轮	1	
12	271514021003	Gasket phi x 28 9 x2	垫圈φ28Xφ9X2	1	
13	▲	Electromagnetic brake	电磁制动器	1	选装/Optional
14	920900100079	Motor(AC)	电机(交流)JXQ	1	
15	271532511001	The encoder	编码器(WN插入式)	1	
16	910100100071	Bolt GB5782 M16x55-8.8	螺栓GB5782-M16x55-8.8	4	
17	910400500010	Spring washer GB93-16	弹簧垫圈GB93-16	4	
18	910400100010	The flat washer GB97.1-16-200 HV	平垫圈GB97.1-16-200HV	4	
19	271514021001	Transmission mounting plate	变速箱安装板	1	
20	271514010001	Gearbox	变速箱	1	
21	940300400013	Driving wheel Φ x140 343	驱动轮Φ343x140	1	
22	216513020000	Hub bolt m14x1.5x25	轮毂螺栓M14x1.5x25	6	

271598501002变速箱(FE3R12)/Gearbox (FE3R12)

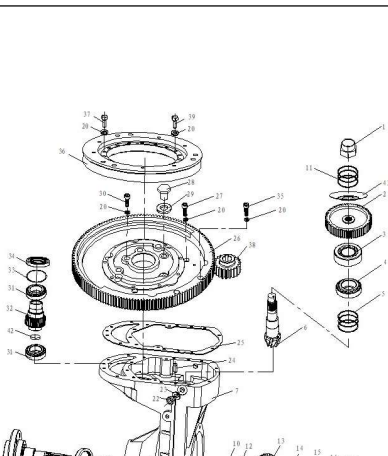

序号/NO	编码/SN	Name	名称	数量/QTY	备注/Remark
1	275214021002	Lock nut QDCS25.006	锁紧螺母QDCS25.006	1	
2	271514021001	Driven gear DDS35LD.006	从动齿轮DDS35LD.006	1	
3	910700600002	Bearing 30206	轴承GB/T297-30206	1	
4	271514021102	Bearing 33206	轴承GB/T297-33206	1	
5	275214021004	Adjustable pad DQS15.011	调整垫DQS15.011	3	
6	271514021103	Cone gear shaft DDS35.008	锥齿轴DDS35.008	1	
7	271514021104	Box DDS35LD.001	箱体DDS35LD.001	1	
8	271514021005	Half axis DDS35LD.007	半轴DDS35LD.007	1	
9	271514021006	Oil seal TC 90×115×12	油封TC90×115×12	1	
10	275214021028	Bearing 33011 GB/T 297	轴承GB/T297-33011	2	
11	271514021007	Adjustable pad DDS30.011	调整垫DDS30.011	3	
12	271514021008	Adjustable pad YDS45.026	调整垫YDS45.026	3	
13	271514021009	Helical bevel gear DDS30.012	螺旋锥齿轮DDS30.012	1	
14	271514021010	Locating sleeve QDCS10.008	定位套QDCS10.008	1	
15	271514021011	lock nut QDCS10.009	锁紧螺母QDCS10.009	1	
16	271514021012	Lock washer QDCS10.014	锁紧垫圈QDCS10.014	1	
17	910200200033	Screw M6×12	螺钉GB/T70.1-M6×12	2	
18	271514021013	O-ring 195×5.3	O型圈 GB/T 3452.1-195×5.3	1	
19	271514021014	Bottom cap DDS35LD.008	底盖DDS35LD.008	1	
20	910400500006	Spring washerGB/T 93-1987-8	垫圈GB/T93-8	31	

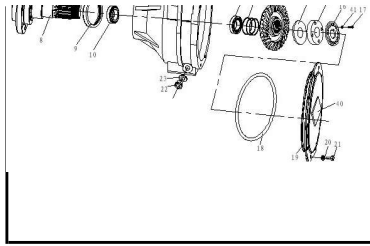

21	910100300022	Bolt M8×20	螺栓GB/T5783-M8×20	8	
22	271514021015	Screw JB/ZQ4444-M14×1.5	螺栓JB/ZQ4444-M14×1.5	2	
23	910800900004	Washer14	垫圈JB/T 982-14	2	
24	271514021016	Pin GB/T119.1-6×16	圆柱销GB/T119.1-6×16	2	
25	271514021017	Paper washer DDS35.004	纸垫DDS35.004	1	
26	271514021018	Case cover DDS35.002	箱盖DDS35.002	1	
27	910200200057	Screw GB/T 70.1-M8×20	螺钉 GB/T 0.1-M8×20	8	
28	271514021019	Vent plug assembly DDS15.903	通气塞组件DDS15.903	1	
29	910800900006	Washer10	组合密封垫圈JB/T982-10	1	
30	910200200059	ScrewM8×30	螺钉GB/T70.1-M8×30	4	
31	275214021007	Bearing 16007	轴承GB/T276-16007	2	

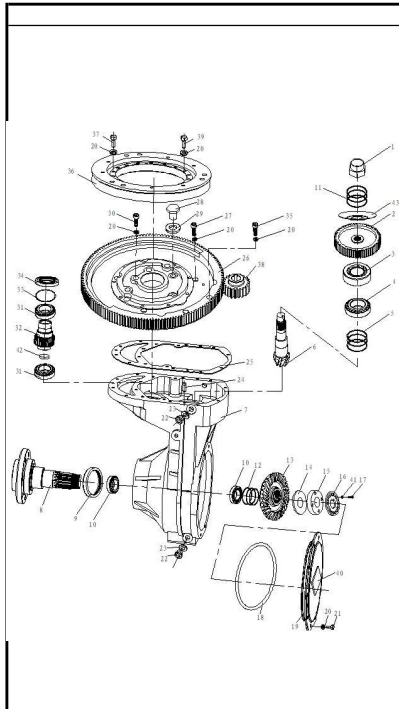

271598501002变速箱(FE3R12N)/Gearbox (FE3R12)					
序号/NO	编码/SN	Name	名称	数量/QTY	备注/Remark
32	271514021020	Input axis DDS35LD.005	输入轴DDS35LD.005	1	
33	271514021021	Check ring GB/T893.1-62	挡圈GB/T 893.1-62	1	
34	271514021022	Oil Seal TC35×62×8	骨架油封TC 35×62×8	1	
35	910200200061	Screw GB/T70.1-M8×40	螺钉GB/T 70.1-M8×40	2	
36	271514021023	Slewing bearing DDS40.901	回转支承DDS40.901	1	
37	910100300025	Bolt GB/T5783-M8×35	螺栓GB/T 5783-M8×35	7	
38	271514021024	Steering pinion DDS35LD1.001	转向小齿轮DDS35LD1.001	1	
39	910100300024	Bolt GB/T5782-M8×30	螺栓GB/T 5782-M8×30	2	
40	271514021025	Labels DCS25H.002	标牌DCS25H.002	1	
41	910400500005	Spring washer GB/T93-6	标准型弹簧垫GB/T93-6	2	
42	271514021026	Choke plug QDCS25.021	闷头QDCS25.021	1	
43	271514021027	Oil baffle gasket DDS35.009	挡油垫片DDS35.009	1	

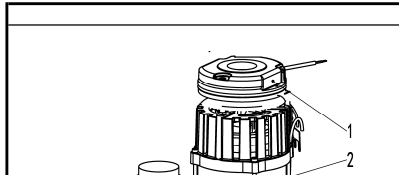

271198501003驱动转向系统(FE3R08-10)/Drive steering system(FE3R08-10)					
序号/NO	编码/SN	Name	名称	数量/QTY	备注/Remark
	▲	Electromagnetic brake	电磁制动器	1	选装/Optional
2	920900100084	Motor(AC)2.5KW	电机(交流)2.5KW	1	
3	910100300012	Bolt GB5783 M6x25-8.8	螺栓GB5783-M6x25-8.8	8	
4	910400500005	Spring washer GB93-6	弹簧垫圈GB93-6	8	
5	910400100005	Flat washer GB97.1-6-200 HV	平垫圈GB97.1-6-200HV	8	
6	910100100071	Bolt GB5782 M16x55-8.8	螺栓GB5782-M16x55-8.8	4	

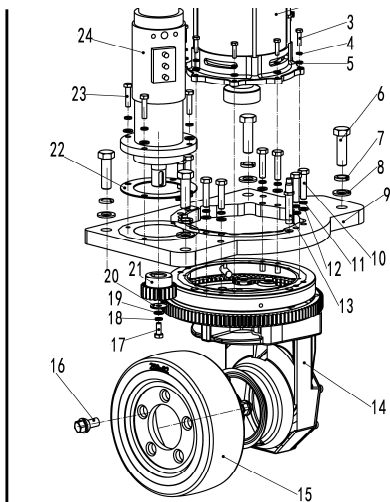

7	910400500010	Spring washer GB93-16	弹簧垫圈GB93-16	4	
8	910400100010	The flat washer GB97.1-16-200 HV	平垫圈GB97.1-16-200HV	4	
9	271114022001	Transmission mounting plate	变速箱安装板	1	
10	910100300040	Bolt GB5783 M10x45-8.8	螺栓GB5783-M10x45-8.8	8	
11	910400500007	Spring washer GB93-10	弹簧垫圈GB93-10	8	
12	910400100007	Flat washer GB97.1-10-200 HV	平垫圈GB97.1-10-200HV	8	
13	920200400007	Approach switch fi4-m12-on6L470	接近开关Fi4-M12-ON6L-L70	1	
14	271114012001	Gearbox	变速箱	1	
15	940300400002	Driving wheel Φ x82 250-250	驱动轮Φ250x82-154005	1	
16	216513020000	Hub bolt m14x1.5x25	轮毂螺栓M14x1.5x25	5	
17	910100300022	Bolt GB5783 M8x20-8.8	螺栓GB5783-M8x20-8.8	1	
18	910400500006	Spring washer GB93-8	弹簧垫圈GB93-8	11	
19	910400100006	The flat washer GB97.1-8-200 HV	平垫圈GB97.1-8-200HV	10	
20	271514021004	Gasket phi phi 28x9x2	垫圈φ28Xφ9X2	1	
21	271114020005	Steering pinion	转向小齿轮	1	
22	271114021002	Gasket (steering motor)	垫片(转向电机)	1	
23	910100300024	Bolt GB5783 M8x30-8.8	螺栓GB5783-M8x30-8.8	4	
24	920900100050	Motor (dc) z90 dpn24400-30s	电机(直流)	1	
25	271132511001	Encoder(ZD)	编码器(ZD)	1	

271598501004 变速箱(FE3R08-10)/Gearbox (FE3R08-10)

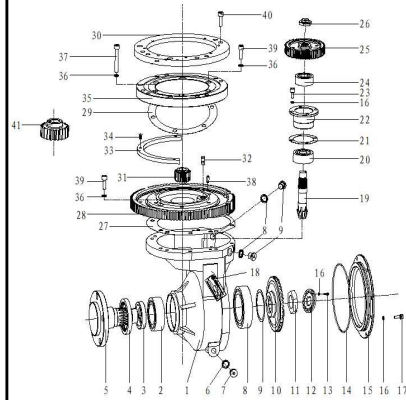

序号/NO	编码/SN	Name	名称	数量/QTY	备注/Remark
1	271114021001	Box DDS25ALD.001	箱体DDS25ALD.001	1	
2	271114021102	Bearing GB/T297-33010	轴承GB/T297-33010	1	
3	271114021003	Bush DDS25.011	衬套DDS25.011	1	
4	271114021004	Oil seal FB65×85×10 GB/T 9877	油封FB65×85×10 GB/T 9877	1	
5	271114021005	Half shaft components DDS25ALD.010G1	半轴组件DDS25ALD.010G1	1	
6	910800900004	Washer14	垫圈JB/T982-14	3	
7	271514021015	Screw JB/ZQ4444-M14×1.5	螺栓JB/ZQ4444-M14×1.5	3	
8	910700600021	BearingGB/T297-32013	轴承GB/T297-32013	1	
9	271114021006	Adjustable pad HDCSB30.010	调整垫HDCSB30.010	3	
10	271114021007	Helical bevel gear 18EL100010	螺旋锥齿轮18EL100010	1	
11	271114021008	Lock nut DDS25ALD.011	锁紧螺母DDS25ALD.011	1	
12	271114021009	Lock washer DDS25ALD.012	锁紧垫圈DDS25ALD.012	1	
13	910200200035	Screw GB/T70.1-M6×12	内六角圆柱头螺钉GB/T70.1-M6×12	2	
14	201098520016	O-ring GB/T 452.1-160×2.65	O形圈 GB/T 452.1-160×2.65	1	
15	271114021010	Side coverDDS25.013	下侧盖DDS25.013	1	
16	910400500005	Spring washer GB/T93-6	垫圈GB/T93-6	15	
17	910100300010	Bolt GB/T5783-M6×16	螺栓GB/T5783-M6×16	9	
18	271114021011	Labels DCS25h.002	标牌DCS25h.002	1	
19	271114021012	Cone gear shaft 18EL100013	锥齿轴18EL100013	1	
20	271114021013	Bearing 32304(NSK)	圆锥滚子轴承32304(进口NSK)	1	
21	271114021014	Adjustable pad DDS25.015	调整垫DDS25.015	3	
22	271114021015	Bearing pedestal DDS25.009	轴承座DDS25.009	1	
23	910200200035	Screw GB/T70.1-M6×16	螺钉GB/T70.1-M6×16	4	
24	271114021016	Bearing 32204(NSK)	圆锥滚子轴承32204(进口NSK)	1	
25	271114021017	Driven gear DDS25ALD.008	从动齿轮DDS25ALD.008	1	
26	271114021018	Lock nut DDS25.020	锁紧螺母DDS25.020	1	
27	271114021019	Paper pad DDS25ALD.006	纸垫DDS25ALD.006	1	
28	271114021020	Case cover DDS25LD1	箱盖DDS25LD1	1	
29	271114021021	Paper pad DDS25ALD.013	纸垫DDS25ALD.013	1	

30	271114021022	Transition plate DDS25LD1.003	过渡盘DDS25LD1.003	1	
31	271114021023	Input gear DDS25.007S	输入齿轮DDS25.007S	1	

271198501004变速箱(FE3R08-10)/Gearbox (FE3R08-10)

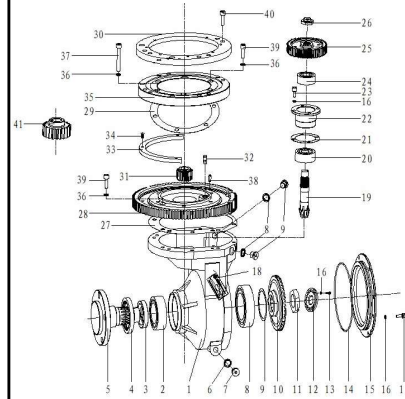

序号/NO	编码/SN	Name	名称	数量/QTY	备注/Remark
32	275214021014	Vent cap Q901 Qc/T 410	通气塞Q901 Qc/T 410	1	
33	271114021024	Induction magnetic stripes DDS25LD1.002	感应磁条DDS25LD1.002	1	
34	910200200023	Screw GB/T70.1-M5×16	螺钉GB/T70.1-M5×16	3	
35	271114021025	Slewing bearing DDS25Ld1.901	回转支承DDS25Ld1.901	1	
36	910400500006	Spring washer GB/T93-8	垫圈GB/T93-8	12	
37	910200200063	Screw GB/T70.1-M8×50	螺钉GB/T70.1-M8×50	4	
38	271514021016	Pin GB/T119.1-6×16	圆柱销GB/T119.1-6×16	2	
39	910200200058	Screw GB/T70.1-M8×25	螺钉GB/T70.1-M8×25	8	
40	910200200151	Screw GB/T70.1-M10×25	螺钉GB/T70.1-M10×25	2	
41	271114021026	Steering pinion DDS25LD1.001	转向小齿轮DDS25LD1.001	1	

271598501005起升电机及油箱安装/Lifting motor and oil tank installation

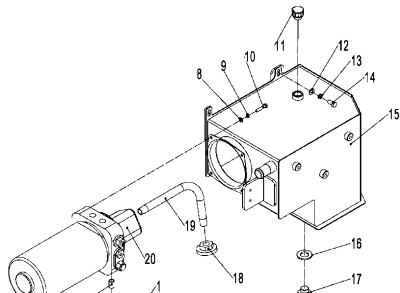

序号/NO	编码/SN	Name	名称	数量/QTY	备注/Remark
1	271519021008	Mounting plate (lifting motor)	安装板(起升电机)	1	
2	910400100007	Flat washer GB97.1-10-200 HV	平垫圈GB97.1-10-200HV	4	
3	910400500007	Spring washer GB93-10	弹簧垫圈GB93-10	4	
4	910100300036	Bolt GB5783 M10x25-8.8	螺栓GB5783-M10x25-8.8	4	
5	255032520002	Gasket phi 40 x 11 x4	垫圈φ40xφ11x4	2	
6	255032520003	Damping pad	减振垫	2	
7	271519021009	Strengthen the set of 13 x 10 x 18 Φ Φ	加强套Φ13xΦ10x18	2	
8	910400100005	Flat washer GB97.1-6-200 HV	平垫圈GB97.1-6-200HV	4	
9	910400500005	Spring washer GB93-6	弹簧垫圈GB93-6	4	
10	910100300011	Bolt GB5783 M6x20-8.8	螺栓GB5783-M6x20-8.8	4	
11	271519010002	Filler cap	加油口盖	1	
12	910400100006	The flat washer GB97.1-8-200 HV	平垫圈GB97.1-8-200HV	2	
13	910400500006	Spring washer GB93-8	弹簧垫圈GB93-8	2	
14	910100300020	Bolt GB5783 M8x16-8.8	螺栓GB5783-M8x16-8.8	2	
15	271519011001	Tank solders	油箱焊合	1	

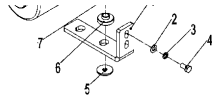

16	910800900001	Combined washer JB982-20	组合垫圈JB982-20	1	
17	255019020015	Drain plug M20x1.5	放油塞M20x1.5	1	
18	271598532501	The filter	过滤器	1	
19	271532520001	Suction tubing	吸油管	1	
20	271532510001	Oil pump motor	油泵电机	1	

转向装置/Steering device

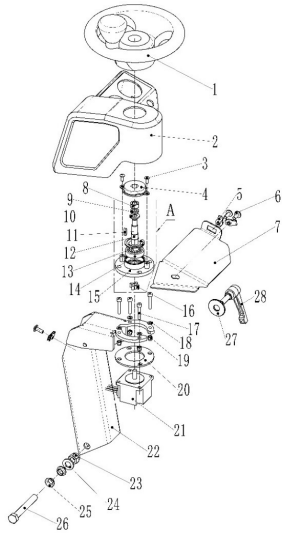

序号/NO	编码/SN	Name	名称	数量/QTY	备注/Remark
1	271531511020	Steering wheel	方向盘Φ202	1	
2	271531521010	Instrument mask	仪表罩	1	
3	910200300012	Screw GB70.2-M5x12-4.8	螺钉GB70.2-M5x12-4.8	2	
4	271531511021	Rotating damper	旋转阻尼器	1	
5	940400400001	Nut M6	薄片螺母M6	3	
6	941100100009	Screw M6x12-8.8	螺钉M6x12-8.8	3	
7	271531521011	Cover plate	仪表罩下封板	1	
8	910300100007	Nut GB6170-M10-10	螺母GB6170-M10-10	1	
9	910400500007	Spring washer GB93-10	弹簧垫圈GB93-10	1	
10	910400100007	washer GB97.1-10-200HV	平垫圈GB97.1-10-200HV	1	
11	910600800002	flat key GB1096-4x12-A	平键GB1096-4x12-A	1	
12	271531523001	connecting shaft	过渡轴(步进电机)	1	
13	910401400011	Retaining ring GB893.1-37	孔用弹性挡圈GB893.1-37	1	
14	910700200045	Bearing GB276-61904-2RS	轴承GB276-61904-2RS	1	
15	271531512010	Bearing seat	轴承座焊合件	1	
16	271531522002	link block	连接块(步进电机)	1	
17	910200200026	Screw GB70.1-M5x30-8.8	螺钉GB70.1-M5x30-8.8	4	
18	910400100004	washer GB97.1-5-200HV	平垫圈GB97.1-5-200HV	4	
19	910300500002	Nut GB889.1-M5-10	螺母GB889.1-M5-10	4	
20	271531522025	shim	垫片(步进电机)	2	
21	921800200004	Potentiometer TY1204-1	电位器TY1204-1	1	
22	271531512001	Direction string welding	转向管柱焊合(电位计)	1	
23	910300500006	Nut GB889.1 - M12-10	螺母GB889.1-M12-10	1	
24	910400100008	washer GB97.1-12-200HV	平垫圈GB97.1-12-200HV	1	
25	940500200028	Wear sleeve Φ12xΦ14x7-SF-1	复合套(带肩)Φ12xΦ14x7-SF-1	2	
26	910100100056	Bolt GB5782-M12x90-8.8	螺栓GB5782-M12x90-8.8	1	
27	910400200004	washer GB96.1-10-200HV	大垫圈GB96.1-10-200HV	1	
28	271531510006	Adjustable handle	可调手柄	1	
A	271531513003	connecting shaft assembly	过渡轴总成(电位计)	1	

电瓶箱盖安装/Battery cover and installation

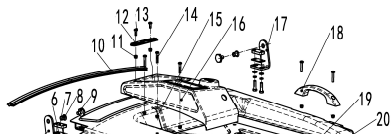

序号/NO	编码/SN	Name	名称	数量/QTY	备注/Remark
1	271521011002	Box cover welding (12)	箱盖焊合(12)	1	FE3R10-12N
	271121011002	Box cover welding (08)	箱盖焊合(08)	1	FE3R08N
2	910100300024	Bolt GB5783 M8x30-8.8	螺栓GB5783-M8x30-8.8	4	
3	910400100006	The flat washer GB97.1-8-200 HV	平垫圈GB97.1-8-200HV	4	
4	910400500006	Spring washer GB93-8	弹簧垫圈GB93-8	4	
5	271521021008	Hinge plate (right)	铰链板(右)	1	
6	271521021015	Adjust the pad	调整垫	2	
7	271521021007	Fixed plate (cover holder)	固定板(顶盖丝座)	2	
8	940500200028	Composite set of 12 x 14 x 7-SF-1	复合套(带肩)Φ12xΦ14x7-SF-1	2	
9	271521021043	Hinge bolts M10x19	铰制螺栓M10x19	2	
10	255022521093	Sealing strip (180 °)	密封条(180°)	0.8m	
11	910300100004	Nut GB6170 - M5-10	螺母GB6170-M5-10	2	

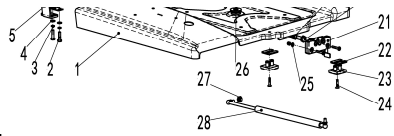

12	255021020067	Folder	文件夹	4	
13	910200500040	Screw GB818 M5x16-4.8	螺钉GB818-M5x16-4.8	2	
14	910200500056	Screw GB818 M6x35-4.8	螺钉GB818-M6x35-4.8	7	
15	910300500003	Nut GB889.1 - M6-10	螺母GB889.1-M6-10	7	
16	271521021003	Top cover	顶盖装饰罩	1	
17	271521021009	Hinge plate (left)	铰链板(左)	1	
18	255021020020	The shake handshandle	拉手	1	
19	910300500006	Nut GB889.1 - M12-10	螺母GB889.1-M12-10	1	
20	255021020052	Locking tongue (roof)	锁舌(顶盖)	1	
21	255021010010	Lid lock	顶盖锁	1	
22	255021020071	Adjustment pad (cushion pad)	调整垫(缓冲垫)	2	
23	255021020068	Cushion	缓冲垫	2	
24	910200400019	Screw GB70.3 M6x25-8.8	螺钉GB70.3-M6x25-8.8	2	
25	910400100005	Flat washer GB97.1-6-200 HV	平垫圈GB97.1-6-200HV	2	
26	255021020046	Skirts Φ 35	保护圈Φ35	1	
27	910300100006	Nut GB6170 M8-10	螺母GB6170-M8-10	2	
28	940400100028	Gas spring 500N (D620)	气弹簧500N(D620)	1	

多路阀罩安装/Multiple valve cover mounting		序号/NO	编码/SN	Name	名称	数量/QTY	备注/Remark
	1	271521021001	Multiple valve underhood	多路阀下罩	1		
	2	271521011005	Control hole plate soldering	操纵孔盖板焊合	1		
	3	910200500040	Screw GB818 M5x16-4.8	螺钉GB818-M5x16-4.8	4		
	4	910400100005	Flat washer GB97.1-6-200 HV	平垫圈GB97.1-6-200HV	2		
	5	910400500005	Spring washer GB93-6	弹簧垫圈GB93-6	2		
	6	255021020051	Support (lower cover of valve)	支架(阀下罩)	1		
	7	940801500001	Jam nut M6	卡式螺母M6	2		
	8	271521021044	Bonnet bracket (right)	阀罩支架(右)	1		
	9	910200500053	Screw GB818 M6x20-4.8	螺钉GB818-M6x20-4.8	4		

仪表架护罩安装/Instrument frame guard		序号/NO	编码/SN	Name	名称	数量/QTY	备注/Remark
	1	271521021004	Instrument frame left cover	仪表架左罩	1		
	2	271521021006	Instrument frame cover	仪表架中罩	1		
	3	910200500053	Screw GB818 M6x20-4.8	螺钉GB818-M6x20-4.8	7		
	4	940801500001	Jam nut M6	卡式螺母M6	1		
	5	271521021005	Instrument frame right cover	仪表架右罩	1		

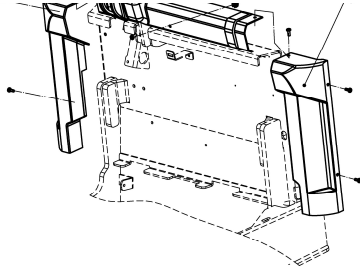

		右侧门安装			
序号/NO	编码/SN	Name	名称	数量/QTY	备注/Remark
1	271521011001	Right side door welding (12)	右侧门焊合(12)	1	FE3R10-12N
	271121011001	Right side door soldering (08)	右侧门焊合(08)	1	FE3R08N
2	910100100023	Bolt GB5782 M8x45-8.8	螺栓GB5782-M8x45-8.8	4	
3	255012020012	Pu tube	聚氨酯管	4	
4	910300100006	Nut GB6170 M8-10	螺母GB6170-M8-10	4	

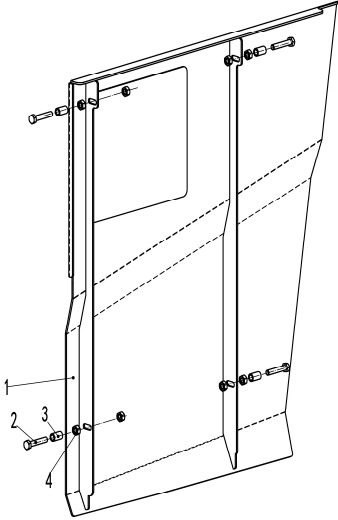

		平衡重安装/Balance weight installation			
序号/NO	编码/SN	Name	名称	数量/QTY	备注/Remark
1	271523021001	Balance weight (12)	平衡重(12)	1	FE3R12N
	271323021001	Balance weight (10)	平衡重(10)	1	FE3R10N
	271123021001	Balance weight (08)	平衡重(08)	1	FE3R08N
2	255023020006	Adjustment pad (counterweight)	调整垫(配重上)	1	
3	281223021007	Plate (weight)	垫板(配重)	2	
4	910400100005	Flat washer GB97.1-6-200 HV	平垫圈GB97.1-6-200HV	2	

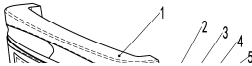

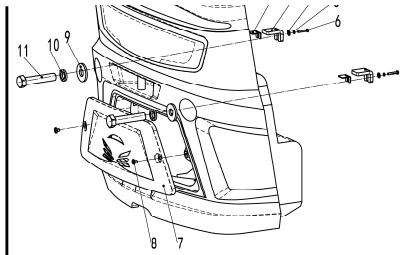

5	910400500005	Spring washer GB93-6	弹簧垫圈GB93-6	2	
6	910100300014	Bolt GB5783 M6x35-8.8	螺栓GB5783-M6x35-8.8	2	
7	271523021002	Balance weight back plate	平衡重后盖板	1	
8	941100100001	Screw M8x12-8.8	螺钉M8x12-8.8	2	
9	255023020007	Gasket Φ 60 x 25 x6	垫圈Φ60xΦ25x6	2	
10	910400500013	Spring washer GB93-24	弹簧垫圈GB93-24	2	
11	910100100101	Bolt GB5782 M24x120-8.8	螺栓GB5782-M24x120-8.8	2	

驻车制动安装/Parking brake installation

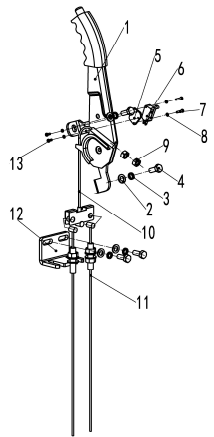

序号/NO	编码/SN	Name	名称	数量/QTY	备注/Remark
1	271512011001	Hand brake	手刹	1	
2	910400100006	The flat washer GB97.1-8-200 HV	平垫圈GB97.1-8-200HV	4	
3	910400500006	Spring washer GB93-8	弹簧垫圈GB93-8	4	
4	910100300022	Bolt GB5783 M8x20-8.8	螺栓GB5783-M8x20-8.8	2	
5	271512021002	Travel switch mounting plate	行程开关固定板	1	
6	920200300009	Travel switch	行程开关	2	
7	910200500012	Screw GB818 M3x16-4.8	螺钉GB818-M3x16-4.8	2	
8	910400500002	Spring washer GB93-3	弹簧垫圈GB93-3	4	
9	910300100006	Nut GB6170 M8-10	螺母GB6170-M8-10	2	
10	271512012001	Transition joint	过渡连接座	2	
11	271512013001	Hand brake line	手刹线	2	
12	271512021001	Mounting bracket (cable)	安装支架(拉线)	1	
13	910200500010	Screw GB818 M3x8-4.8	螺钉GB818-M3x8-4.8	2	

护顶架安装/Roof holder and installation

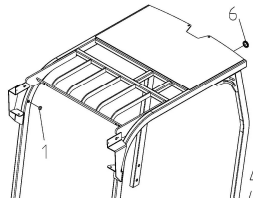

序号/NO	编码/SN	Name	名称	数量/QTY	备注/Remark
A	271522011001	Roof welding	护顶架焊合	1	FE3R10-12N
B	271122011001	Roof welding	护顶架焊合	1	FE3R08N
1	252022020050	Charging socket line washer	充电插座线垫圈	3	
2	910300100008	Nut GB6170 - M12-10	螺母GB6170-M12-10	4	
3	910400500008	Spring washer GB93-12	弹簧垫圈GB93-12	8	
4	910400100008	The flat washer GB97.1-12-200 HV	平垫圈GB97.1-12-200HV	8	
5	910100300050	Bolt GB5783 M12x30-8.8	螺栓GB5783-M12x30-8.8	8	
6	255022020004	Tail out coil	尾灯出线圈	2	

脚制动操纵管路/Foot brake control line

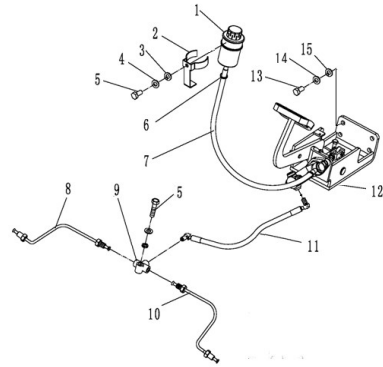

序号/NO	编码/SN	Name	名称	数量/QTY	备注/Remark
1	275011520020	Brake oil cup	制动油杯	1	
2	272011520010	Stand (oil cup)	支架(油杯)	1	
3	910400100006	The flat washer GB97.1-8-200 HV	平垫圈GB97.1-8-200HV	2	
4	910400500006	Spring washer GB93-8	弹簧垫圈GB93-8	2	
5	910100300024	Bolt GB5783 M8x30-8.8	螺栓GB5783-M8x30-8.8	1	
6	911000600001	Hose hoops QC/T390 - (11-14)	喉箍QC/T390-(11-14)	2	
7	900200301003	Rubber hose Φ 8 x Φ 11	橡胶管Φ8xΦ11	1	
8	271511511002	Brake steel tube 1	制动钢管1	1	
9	275211520011	Connection (tee) 3-3xm10x1	接头(三通)3-3xm10x1	1	
10	271511511003	Brake steel tube 2	制动钢管2	1	
11	275211520010	Brake tubing assembly	制动油管总成	1	
12	271511511001	Foot brake assembly	脚制动总成	1	
13	910200200142	Screw GB70.1 M10x20-12.9	螺钉GB70.1-M10x20-12.9	4	
14	910400500007	Spring washer GB93-10	弹簧垫圈GB93-10	4	
15	910400100007	Flat washer GB97.1-10-200 HV	平垫圈GB97.1-10-200HV	4	

前底板/Front floor and installation

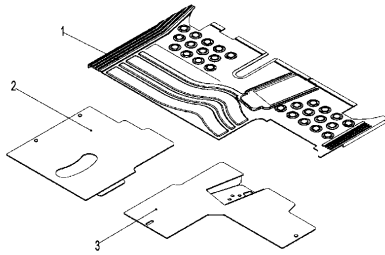

序号/NO	编码/SN	Name	名称	数量/QTY	备注/Remark
1	271518021005	Floor mat	地板垫	1	
2	271518011001	Weld on left base plate	左底板焊合	1	
3	271518011002	Right bottom plate soldering	右底板焊合	1	

前轮总成/Front wheel assembly

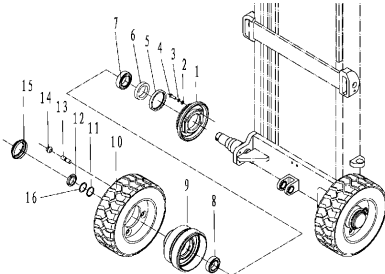

序号/NO	编码/SN	Name	名称	数量/QTY	备注/Remark
1	271515520008	Brake assembly 1	制动器总成(左)	1	左
	271515520006	Brake assembly 2	制动器总成(右)	1	右
2	910400100006	The flat washer GB97.1-8-200 HV	平垫圈GB97.1-8-200HV	4	
3	910400500006	Spring washer GB93-8	弹簧垫圈GB93-8	4	
4	910200200058	Screw GB70.1 M8x25-8.8	螺钉GB70.1-M8x25-8.8	4	
5	910800700002	Skeleton oil seal 75x90x12	骨架油封75x90x12	2	
6	271515520001	Bushing Φ 75 x Φ x15 54	衬套Φ75xΦ54x15	2	
7	910700600017	Bearing GB297-32009	轴承GB297-32009	2	
8	910700600016	Bearing GB297-32008	轴承GB297-32008	2	
9	271515520004	Brake drum	制动鼓	2	
10	272015510002	Tyre 13x41/2x8(solid)	轮胎13x41/2x8(实心)	2	
	272015510007	Tyre 13x41/2x8(environmentally)	轮胎13x41/2x8(环保)	2	选装/Optional
11	271515520003	Gasket Φ 50 x Φ 36 x4	垫圈Φ50xΦ36x4	2	
12	910300800006	Nut GB812 - M35x1.5	螺母GB812-M35x1.5	2	
13	271515520005	Double-headed stud m14x1.5x50	双头螺栓M14x1.5x50	2	

14	275215520008	Nut M14x1.5	螺母M14x1.5	8	
15	271515520002	Blocking cover	堵盖	2	
16	910400900006	Stop washer GB858-35	止动垫圈GB858-35	2	

多路换向阀操纵(二联)/Multi-way reversing valve operation (two)

序号/NO	编码/SN	Name	名称	数量/QTY	备注/Remark
1	255024520023	Handle ball (incline)	手柄球(倾斜)	1	
2	271524511005	Joystick welding (incline)	操纵杆焊合(倾斜)	1	
3	255024520022	Handle ball (lifting)	手柄球(起升)	1	
4	271524511004	Stick welding (lifting)	操纵杆焊合(起升)	1	
5	255024520065	sheath	护套	2	
6	940500100006	Composite set $\Phi 16 \times \Phi 18 \times 15 - SF - 1$	复合套 $\Phi 16 \times \Phi 18 \times 15 - SF - 1$	4	
7	255024510009	With trunnion $\Phi 16 \times 168$	带耳轴 $\Phi 16 \times 168$	1	
8	910400100005	Flat washer GB97.1-6-200 HV	平垫圈GB97.1-6-200HV	9	
9	910400500005	Spring washer GB93-6	弹簧垫圈GB93-6	7	
10	910100300009	Bolt GB5783 M6x12-8.8	螺栓GB5783-M6x12-8.8	5	
11	910400100007	Flat washer GB97.1-10-200 HV	平垫圈GB97.1-10-200HV	6	
12	910400500007	Spring washer GB93-10	弹簧垫圈GB93-10	6	
13	910100300036	Bolt GB5783 M10x25-8.8	螺栓GB5783-M10x25-8.8	4	
14	271524521017	Connecting rod	连接杆	2	
15	910300100006	Nut GB6170 M8-10	螺母GB6170-M8-10	2	
16	255025020003	joint	接头	2	
17	941100800001	Pin B4.75 x20 - c1B	销轴B4.75x20-c1B	4	
18	910600600011	Cotter pin GB91-2 x12	开口销GB91-2x12	4	
19	271524511001	Multi-way valve (double joint)	多路阀(二联)	1	
20	255024520027	Bracket (travel switch)	支架(行程开关)	2	

多路换向阀操纵(三联)/Multi-way reversing valve control (three)

序号/NO	编码/SN	Name	名称	数量/QTY	备注/Remark
1	255025020002	Handle ball (1)	手柄球(属具1)	1	
2	271525011006	Joystick welding (equipment 1)	操纵杆焊合(属具1)	1	
3	255024520023	Handle ball (incline)	手柄球(倾斜)	1	
4	271524511005	Joystick welding (incline)	操纵杆焊合(倾斜)	1	
5	255024520022	Handle ball (lifting)	手柄球(起升)	1	
6	271524511004	Stick welding (lifting)	操纵杆焊合(起升)	1	
7	255024520065	sheath	护套	3	
8	940500100006	Composite set $\Phi 16 \times \Phi 18 \times 15 - SF - 1$	复合套 $\Phi 16 \times \Phi 18 \times 15 - SF - 1$	6	
9	255024510009	With trunnion $\Phi 16 \times 168$	带耳轴 $\Phi 16 \times 168$	1	
10	910400100005	Flat washer GB97.1-6-200 HV	平垫圈GB97.1-6-200HV	9	
11	910400500005	Spring washer GB93-6	弹簧垫圈GB93-6	7	
12	910100300009	Bolt GB5783 M6x12-8.8	螺栓GB5783-M6x12-8.8	5	
13	910400100007	Flat washer GB97.1-10-200 HV	平垫圈GB97.1-10-200HV	6	
14	910400500007	Spring washer GB93-10	弹簧垫圈GB93-10	6	
15	910100300036	Bolt GB5783 M10x25-8.8	螺栓GB5783-M10x25-8.8	4	
16	271524521017	Connecting rod	连接杆	3	
17	910300100006	Nut GB6170 M8-10	螺母GB6170-M8-10	3	
18	255025020003	joint	接头	3	
19	941100800001	Pin B4.75 x20 - c1B	销轴B4.75x20-c1B	6	
20	910600600011	Cotter pin GB91-2 x12	开口销GB91-2x12	6	
21	271523520007	Joint (lock) $10 \times M20 \times 1.5 - M14 \times 1.5 - 60^\circ$	接头(锁定弯) $10 \times M20 \times 1.5 - M14 \times 1.5 - 60^\circ$	1	
22	271523520008	Joint (lock) $10 \times M20 \times 1.5 - M14 \times 1.5 - 60^\circ$	接头(锁定弯) $10 \times M20 \times 1.5 - M14 \times 1.5 - 60^\circ$	1	
23	271525011001	Multi-way valve (sanxin triad)	多路阀(三联)	1	
24	255024520027	Bracket (travel switch)	支架(行程开关)	3	

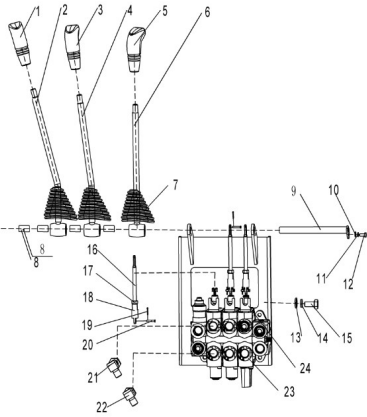

多路换向阀操纵(四联)/Multi-way reversing valve control (Four)

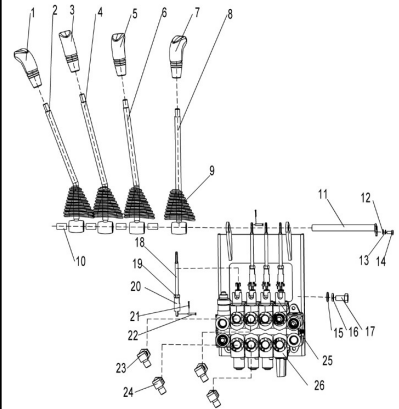

序号/NO	编码/SN	Name	名称	数量/QTY	备注/Remark
1	255025520002	Handle ball (2)	手柄球(属具2)	1	
2	271525511007	Stick welding (equipment 2)	操纵杆焊合(属具2)	1	
3	255025020002	Handle ball (1)	手柄球(属具1)	1	
4	271525011006	Joystick welding (equipment 1)	操纵杆焊合(属具1)	1	
5	255024520023	Handle ball (incline)	手柄球(倾斜)	1	
6	271524511005	Joystick welding (incline)	操纵杆焊合(倾斜)	1	
7	255024520022	Handle ball (lifting)	手柄球(起升)	1	
8	271524511004	Stick welding (lifting)	操纵杆焊合(起升)	1	
9	255024520065	sheath	护套	4	
10	940500100006	Composite set $\Phi 16 \times \Phi 18 \times 15 - SF - 1$	复合套 $\Phi 16 \times \Phi 18 \times 15 - SF - 1$	1	
11	255024510009	With trunnion $\Phi 16 \times 168$	带耳轴 $\Phi 16 \times 168$	8	
12	910400100005	Flat washer GB97.1-6-200 HV	平垫圈GB97.1-6-200HV	9	
13	910400500005	Spring washer GB93-6	弹簧垫圈GB93-6	7	
14	910100300009	Bolt GB5783 M6x12-8.8	螺栓GB5783-M6x12-8.8	5	
15	910400100007	Flat washer GB97.1-10-200 HV	平垫圈GB97.1-10-200HV	6	
16	910400500007	Spring washer GB93-10	弹簧垫圈GB93-10	6	
17	910100300036	Bolt GB5783 M10x25-8.8	螺栓GB5783-M10x25-8.8	4	
18	271524521017	Connecting rod	连接杆	4	
19	910300100006	Nut GB6170 M8-10	螺母GB6170-M8-10	4	
20	255025020003	joint	接头	4	
21	941100800001	Pin B4.75 x20 - c1B	销轴B4.75x20-c1B	8	
22	910600600011	Cotter pin GB91-2x12	开口销GB91-2x12	8	
23	271523520007	Joint (lock) 10 - M20x1.5 - M14x1.5 - 60°	接头(锁定弯)10-M20x1.5-M14x1.5-60°	2	
24	271523520008	Joint (lock) 10 - M20x1.5 - M14x1.5 - 60°	接头(锁定弯)10-M20x1.5-M14x1.5-60°	2	
25	255024520027	Bracket (travel switch)	支架(行程开关)	4	
26	271525511001	Multi-way valve (four links)	多路阀(四联)	1	

液压系统/Hydraulic system

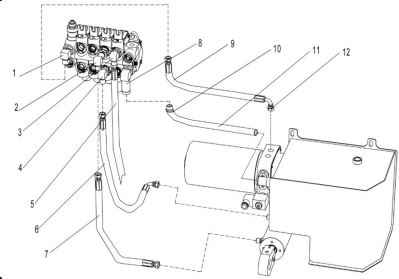

序号/NO	编码/SN	Name	名称	数量/QTY	备注/Remark
1	281244529001	Bending joint (lock) 12 - M18x1.5 - M22x1.5-60°	接头(锁定弯)12-M18x1.5-M22x1.5-60°	1	
2	281225010001	Joint (lock) 10 - M20x1.5 - M16x1.5-60°	接头(锁定弯)10-M20x1.5-M16x1.5-60°	1	
3	255023510007	Joint (lock) 10 - M20x1.5 - M16x1.5-60°	接头(锁定弯)10-M20x1.5-M16x1.5-60°	1	
4	271523520002	Bending joint (lock) 12 - M20x1.5 - M18x1.5-60°	接头(锁定弯)12-M20x1.5-M18x1.5-60°	1	
5	271523520003	Hydraulic tube assembly (90°) 10 - SC-1500-1.60°	液压管总成(90°)10-L500-1SC-60°	1	
6	275223521005	Hydraulic tube assembly (straight) 6 - L700-1.60°	液压管总成(直)6-L700-1SC-60°	1	
7	275223521006	Hydraulic tube assemblies (90°) 6 - L700-1.60°	液压管总成(90°)6-L700-1SC-60°	1	
8	255023510002	Joint (16 to bend) - M22x1.5 - $\Phi 25$	接头(转向弯)16-M22x1.5- $\Phi 25$	1	
9	271523520003	Hydraulic tube assembly (90°) 10 - SC-1500-1.60°	液压管总成(90°)10-L500-1SC-60°	1	
10	911000600004	Hose hoops QC/T390 - 38 (34)	喉箍QC/T390-(34-38)	1	
11	900200401003	Oil return hose $\Phi \Phi \times 25$ to 35	回油胶管 $\Phi 25 \times \Phi 35$	1	
12	271523520005	Joint (lock) 12 - G3/8 - M18x1.5-60°	接头(锁定弯)12-G3/8-M18x1.5-60°	1	

门架起升管路(标准门架)/Lifting pipeline (standard mast)

序号/NO	编码/SN	Name	名称	数量/QTY	备注/Remark
1	271544029005	Joint (straight) 10-M20x1.5-M18x1.5-60°	接头(直)10-M20x1.5-M18x1.5-60°	2	
2	271544011100	Tri-body welding	三通体焊合	1	
3	950700300009	Speed limiting valve	限速阀XSF-F16L-14-6	1	
4	271544029007	Hydraulic Pipe Assembly Type S (90°) 12-L360-2SC-60°	液压管总成S型(90°)12-L360-2SC-60°	1	
5	255030520008	Hydraulic pipe assembly 10-L360-1SC-60°	液压管总成(直)10-L360-1SC-60°	1	

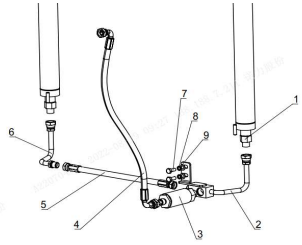

6	271544019001	Hydraulic steel tube assembly (left)	液压钢管总成 (左)	1	
7	910100300022	Bolt GB5783-M8x20-8.8	螺栓GB5783-M8x20-8.8	2	
8	910400100006	Washer GB97.1-8-200HV	平垫圈GB97.1-8-200HV	2	
9	910400500006	Spring washer GB93-8	弹簧垫圈GB93-8	2	
10	271598520002	Anti-explosion Valve	防爆阀	1	

门架起升管路 (二级全自由门架)/Lifting pipeline (two-stage full free mast)

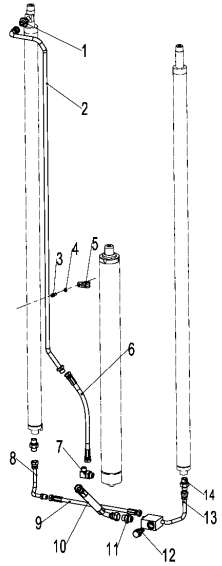

序号/NO	编码/SN	Name	名称	数量/QTY	备注/Remark
1	255023520034	Joint (straight) 8-2 xm16x1.5-60°	接头(直)8-2xm16x1.5-60°	1	
2	271543529107	Lifting steel pipe welding L=820	起升钢管焊合L=820	1	H=2000
	271543529101	Lifting steel pipe welding L=960	起升钢管焊合L=960	1	H=2500/2700
	271543529102	Lifting steel pipe welding L=1200	起升钢管焊合L=1200	1	H=3000/3300
	271543529103	Lifting steel pipe welding L=1450	起升钢管焊合L=1450	1	H=3500/3700
	271543529104	Lifting steel pipe welding L=1650	起升钢管焊合L=1650	1	H=4000
3	910200200035	Screw GB70.1 M6x16-8.8	螺钉GB70.1-M6x16-8.8	1	
4	910400500005	Spring washer GB93-6	弹簧垫圈GB93-6	1	
5	951000100003	Pipe clamp YGE wrap 15	管夹YGE包胶15	1	
6	271543529111	Hydraulic tube assembly (straight) 12-	液压管总成(直) 12-L300-1SC-60°	1	H=2000
	271543529111	Hydraulic tube assembly (straight) 12-	液压管总成(直) 12-L300-1SC-60°	1	H=2500
	271543529112	Hydraulic tube assembly (straight) 12-	液压管总成(直) 12-L400-1SC-60°	1	H=2700
	271543529113	Hydraulic tube assembly (straight) 12-	液压管总成(直) 12-L360-1SC-60°	1	H=3000
	271543529114	Hydraulic tube assembly (straight) 12-	液压管总成(直) 12-L500-1SC-60°	1	H=3300
	271543529113	Hydraulic tube assembly (straight) 12-	液压管总成(直) 12-L360-1SC-60°	1	H=3500
	271543529114	Hydraulic tube assembly (straight) 12-	液压管总成(直) 12-L500-1SC-60°	1	H=3700
7	281244529001	Joint (lock) 12-M18x1.5-M22x1.5-60°	接头(锁定弯)12-M18x1.5-M22x1.5-60°	1	
8	271544019001	Hydraulic steel tube assembly (left)	液压钢管总成(左)	1	
9	255030520008	Hydraulic tube assembly (straight) 10-L360-1SC-60°	液压管总成(直)10-L360-1SC-60°	1	
10	271544029007	Hydraulic tube assembly (90°) 12-L560-2SC-60°	液压管总成(90°) 12-L560-2SC-60°	1	
11	255023520030	Joint (straight)12-2xm22x1.5-60°	接头(直)12-2xm22x1.5-60°	1	
12	950700300009	Speed limiting valve	限速阀XSF-F16L-14-6	1	
13	271544011100	The tee body is welded	三通体焊合	1	
14	271544029005	Joint (straight)10-M20x1.5-M18x1.5-60°	接头(直)10-M20x1.5-M18x1.5-60°	2	
15	271598520002	Anti-explosion Valve	防爆阀	1	

门架起升管路 (三级全自由)/Lifting pipeline (three-stage full free mast)

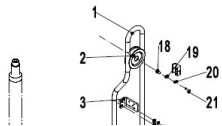

序号/NO	编码/SN	Name	名称	数量/QTY	备注/Remark
1	271544529501	Hydraulic tube assembly (straight) 12-L3180-2SC-60°	液压管总成(直)12-L3180-2SC-60°	1	H=4000
	254144520043	Hydraulic tube assembly (straight) 12-L3250-2SC-60°	液压管总成(直)12-L3250-2SC-60°	1	H=4350
	254144520044	Hydraulic tube assembly (straight) 12-L3450-2SC-60°	液压管总成(直)12-L3450-2SC-60°	1	H=4500
	254144520045	Hydraulic tube assembly (straight) 12-L3650-2SC-60°	液压管总成(直)12-L3650-2SC-60°	1	H=4800
	271544520004	Hydraulic tube assembly (straight) 12-L3850-2SC-60°	液压管总成(直)12-L3850-2SC-60°	1	H=5000
2	271544529004	Pulley Φ84x18(single)	滑轮Φ84x18(单槽)	1	
3	271544529005	Installation plate (main)	安装板(主)	1	

侧移器及管路安装 (二级全自由门架) /Side shifter and pipeline installation(two-stage full free mast)

序号/NO	编码/SN	Name	名称	数量/QTY	备注/Remark
1	271528511001	Four-way valve assembly (triple)	四通阀总成 (三联)	1	
2	910100300022	Bolt GB5783 M8x20-8.8	螺栓GB5783-M8x20-8.8	3	
3	910400500006	Spring washer GB93-8	弹簧垫圈GB93-8	10	
4	910400100006	The flat washer GB97.1-8-200 HV	平垫圈GB97.1-8-200HV	8	
5	910200200059	Screw GB70.1 M8x30-8.8	螺钉GB70.1-M8x30-8.8	2	
6	910300100006	Nut GB6170 M8-10	螺母GB6170-M8-10	2	
7	910100300020	Bolt GB5783 M8x16-8.8	螺栓GB5783-M8x16-8.8	5	
8	271528510101	Soldering L=570	外导槽焊合L=570	1	H=2500
	271528510102	Outer guide groove welding L=670	外导槽焊合L=670	1	H=2700
	271528510103	Outer guide groove welding L=820	外导槽焊合L=820	1	H=3000
	271528510104	Outer guide groove welding L=970	外导槽焊合L=970	1	H=3300
	271528510105	Outer guide groove welding L=1070	外导槽焊合L=1070	1	H=3500
	271528510106	Soldering of outer guide groove L=1170	外导槽焊合L=1170	1	H=3700
	271528510107	Outer guide groove welding L=1370	外导槽焊合L=1370	1	H=4000
9	271528520161	Hydraulic tube assembly (straight) 6-L2050-1SC-60°	液压管总成 (直) 6-L2050-1SC-60°	2	H=2500
	271528520157	Hydraulic tube assembly (straight) 6-L2250-1SC-60°	液压管总成 (直) 6-L2250-1SC-60°	2	H=2700
	271528520162	Hydraulic tube assembly (straight) 6-L2550-1SC-60°	液压管总成 (直) 6-L2550-1SC-60°	2	H=3000
	271528520163	Hydraulic tube assembly (straight) 6-L2850-1SC-60°	液压管总成 (直) 6-L2850-1SC-60°	2	H=3300
	271528520164	Hydraulic tube assembly (straight) 6-L3150-1SC-60°	液压管总成 (直) 6-L3150-1SC-60°	2	H=3500
	271528520165	Hydraulic tube assembly (straight) 6-L3350-1SC-60°	液压管总成 (直) 6-L3350-1SC-60°	2	H=3700
	271528520166	Hydraulic tube assembly (straight) 6-L3650-1SC-60°	液压管总成 (直) 6-L3650-1SC-60°	2	H=4000
10	271528520151	Hydraulic tube assembly (straight) 6-L1500-1SC-60°	液压管总成 (直) 6-L1500-1SC-60°	2	H=2500
	271528520152	Hydraulic tube assembly (straight) 6-L1600-1SC-60°	液压管总成 (直) 6-L1600-1SC-60°	2	H=2700
	271528520153	Hydraulic tube assembly (straight) 6-L1750-1SC-60°	液压管总成 (直) 6-L1750-1SC-60°	2	H=3000
	271528520154	Hydraulic tube assembly (straight) 6-L1900-1SC-60°	液压管总成 (直) 6-L1900-1SC-60°	2	H=3300
	271528520155	Hydraulic tube assembly (straight) 6-L2000-1SC-60°	液压管总成 (直) 6-L2000-1SC-60°	2	H=3500
	271528520156	Hydraulic tube assembly (straight) 6-L2100-1SC-60°	液压管总成 (直) 6-L2100-1SC-60°	2	H=3700
	271528520157	Hydraulic tube assembly (straight) 6-L2250-1SC-60°	液压管总成 (直) 6-L2250-1SC-60°	2	H=4000
11	271528510111	Inner guide groove welding L=495	内导槽焊合L=495	1	H=2500
	271528510112	Inner guide groove welding L=595	内导槽焊合L=595	1	H=2700
	271528510113	Inner guide groove welding L=745	内导槽焊合L=745	1	H=3000
	271528510114	Inner guide groove welding L=895	内导槽焊合L=895	1	H=3300

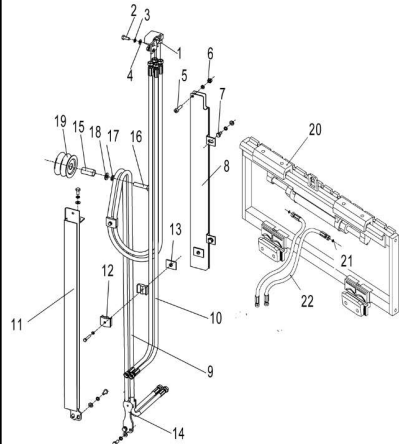

侧移器及管路安装 (二级全自由门架) /Side shifter and pipeline installation(two-stage full free mast)

序号/NO	编码/SN	Name	名称	数量/QTY	备注/Remark
11	271528510115	Inner guide groove welding L=995	内导槽焊合L=995	1	H=3500
	271528510116	Inner guide groove welding L=1095	内导槽焊合L=1095	1	H=3700
	271528510117	Inner guide groove welding L=1245	内导槽焊合L=1245	1	H=4000
12	271544001101	Double pipe clamp	双孔管夹	5	
13	271530520103	Mounting plate	安装板	2	
14	910100300022	Bolt GB5783 M8x20-8.8	螺栓GB5783-M8x20-8.8	4	
15	271530520105	Shaft sleeve Φ 17 Φ x41 12.5 x	轴套Φ17xΦ12.5x41	2	
16	910100300055	Bolt GB5783 M12x55-8.8	螺栓GB5783-M12x55-8.8	1	
17	910400500008	Spring washer GB93-12	弹簧垫圈GB93-12	1	
18	910400100008	The flat washer GB97.1-12-200 HV	平垫圈GB97.1-12-200HV	1	
19	271527521003	Pulley Φ x46 74 (dual slot)	滑轮Φ74x46(双槽)	1	
20	272042510001	Side shifter assembly (linkage)	侧移器总成	1	
21	910800100001	O-ring - internal 9.5x1.8	O形圈-内9.5x1.8	1	

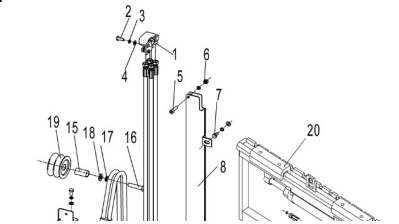

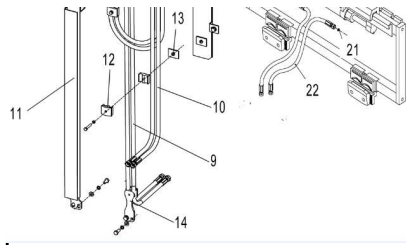

侧移器及管路安装 (三级全自由门架) Side shifter and pipeline installation(three-stage full free mast)

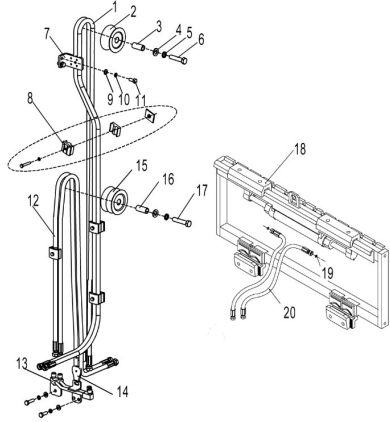

序号/NO	编码/SN	Name	名称	数量/QTY	备注/Remark
1	272327520002	Hydraulic tube assembly (straight) 8-L3800-1-60°	液压管总成(直)8-L3800-1SC-60°	2	H=4000
	271529020155	Hydraulic tube assembly (straight) 8-L3910-1-60°	液压管总成(直)8-L3910-1SC-60°	2	H=4350
	271527520004	Hydraulic tube assembly (straight) 8-L4000-1-60°	液压管总成(直)8-L4000-1SC-60°	2	H=4500
	271527520005	Hydraulic tube assembly (straight) 8-L4200-1-60°	液压管总成(直)8-L4200-1SC-60°	2	H=4800
	271527520006	Hydraulic tube assembly (straight) 8-L4400-1-60°	液压管总成(直)8-L4400-1SC-60°	2	H=5000
2	271530520104	Pulley Φ x38 54 (single slot)	滑轮Φ54x38(单槽)	1	
3	271530520105	Bushing Φ x33 13 x 20	衬套Φ20xΦ13x33	1	
4	910400100008	The flat washer GB97.1-12-200 HV	平垫圈GB97.1-12-200HV	2	
5	910400500008	Spring washer GB93-12	弹簧垫圈GB93-12	1	
6	910100300055	Bolt GB5783 M12x55-8.8	螺栓GB5783-M12x55-8.8	1	
7	271530520102	Hose clamp	胶管固定板	1	
8	271544001101	Double pipe clamp	双孔管夹	5	
9	910400100006	The flat washer GB97.1-8-200 HV	平垫圈GB97.1-8-200HV	7	
10	910400500006	Spring washer GB93-8	弹簧垫圈GB93-8	7	
11	910100300023	Bolt GB5783 M8x25-8.8	螺栓GB5783-M8x25-8.8	7	
12	271530520151	Hydraulic tube assembly (straight) 8-L1990-1SC-60°-0°	液压管总成(直)8-L1990-1SC-60°-0°	2	H=4000
	271530520152	Hydraulic tube assembly (straight) 8-L2050-1SC-60°-0°	液压管总成(直)8-L2050-1SC-60°-0°	2	H=4350
	271530520153	Hydraulic tube assembly (straight) 8-L2140-1SC-60°-0°	液压管总成(直)8-L2140-1SC-60°-0°	2	H=4500
	271530520154	Hydraulic tube assembly (straight) 8-L2240-1SC-60°-0°	液压管总成(直)8-L2240-1SC-60°-0°	2	H=4800
	271530520155	Hydraulic tube assembly (straight) 8-L2340-1SC-60°-0°	液压管总成(直)8-L2340-1SC-60°-0°	2	H=5000
13	271530511001	Hydraulic steel tube assembly (triple)	液压钢管总成(三联)	1	
14	271530520103	Mounting plate	安装板	1	
15	271527521003	Pulley Φ x46 74 (dual slot)	滑轮Φ74x46(双槽)	3	
16	271530520106	Bushing Φ x41 13 x 20	衬套Φ20xΦ13x41	1	
17	910100300056	Bolt GB5783 M12x60-8.8	螺栓GB5783-M12x60-8.8	1	
18	272042510001	Side shifter assembly (linkage)	侧移器总成(联动)	1	
19	910800100001	O-ring - internal 9.5x1.8	O形圈-内9.5x1.8	2	

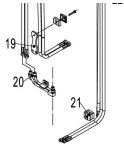

货叉/Fork					
序号/NO	编码/SN	Name	名称	数量/QTY	备注/Remark
A	940100100001	Fork 100 x35x920	挂钩IIA型货叉100x35x920	2	包括/inc.1-2
	940100100002	Fork 100 x35x950	挂钩IIA型货叉100x35x950	2	
	940100100003	Fork 100 x35x1070	挂钩IIA型货叉100x35x1070	2	
	940100100004	Fork 100 x35x1150	挂钩IIA型货叉100x35x1150	2	
	940100100005	Fork 100 x35x1220	挂钩IIA型货叉100x35x1220	2	
1	▲	Fork body	货叉体	2	
2	253098514101	Lift pin assembly	提销总成	2	

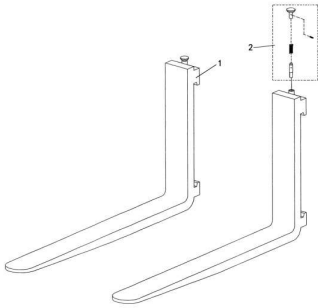

货叉架 (标准门架)/Fork rack (standard mast)					
序号/NO	编码/SN	Name	名称	数量/QTY	备注/Remark
1	271540511001	Shelf welding (825x878)	挡货架焊合(825x878)	1	
2	910100300050	Bolt GB5783 M12x30-8.8	螺栓GB5783-M12x30-8.8	4	
3	910400500008	Spring washer GB93-12	弹簧垫圈GB93-12	4	

货叉架 (三级全自由门架)/Fork rack (Three-stage full free mast)					
序号/NO	编码/SN	Name	名称	数量/QTY	备注/Remark
1	271540511001	Shelf welding (825x878)	挡货架焊合(825x878)	1	
2	910400500008	Spring washer GB93-12	弹簧垫圈GB93-12	4	
3	910400100008	The flat washer GB97.1-12-200 HV	平垫圈GB97.1-12-200HV	4	
4	910100300050	Bolt GB5783 M12x30-8.8	螺栓GB5783-M12x30-8.8	4	
5	271538013001	Fork rack (three-stage full free mast)	货叉架焊合(三级全自由门架)	1	
6	940200300003	Composite roller Φ 70.6 = 43.5-47.5	复合滚轮 Φ 70.6-range=43.5-47.5	4	
7	910401300018	Axis with elastic catch GB894.1-35	轴用弹性挡圈GB894.1-35	4	

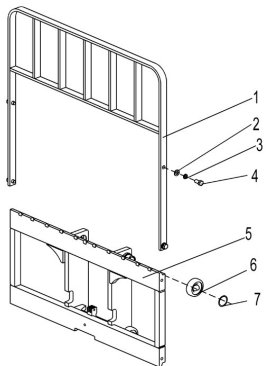

门架 (标准门架)/Mast (standard mast)					
序号/NO	编码/SN	Name	名称	数量/QTY	备注/Remark
1	910401300018	Axis with elastic catch GB894.1-35	轴用弹性挡圈GB894.1-35	4	
2	940200300003	Composite roller Φ 70.6 = 43.5-47.5	复合滚轮 Φ 70.6-range=43.5-47.5	4	
3	271544011001	Outside mast (2500)	外门架(2500)	1	H=2500
	271544011002	Outside mast (2700)	外门架(2700)	1	H=2700
	271544011003	Outside mast (3000)	外门架(3000)	1	H=3000
	271544011004	Outside mast (3300)	外门架(3300)	1	H=3300
	271544011005	Outside mast (3500)	外门架(3500)	1	H=3500
	271544011006	Outside mast (3700)	外门架(3700)	1	H=3700
	271544011007	Outside mast (4000)	外门架(4000)	1	H=4000

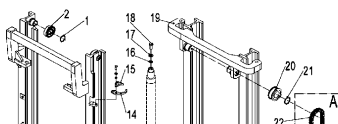

--	--	--	--	--	--

门架（二级全自由门架）/Mast (two-stage full free mast)						
序号/NO	编码/SN	Name	名称	数量/QTY	备注/Remark	
1	910100300051	Bolt GB5783 M12x35-8.8	螺栓GB5783-M12x35-8.8	2		
2	910400500008	Spring washer GB93-12	弹簧垫圈GB93-12	2		
3	910400100008	The flat washer GB97.1-12-200 HV	平垫圈GB97.1-12-200HV	2		
4	910100300024	Bolt GB5783 M8x30-8.8	螺栓GB5783-M8x30-8.8	4		
5	910400500006	Spring washer GB93-8	弹簧垫圈GB93-8	6		
6	910400100006	The flat washer GB97.1-8-200 HV	平垫圈GB97.1-8-200HV	6		
7	275244020003	The hoop	外抱箍	2		
8	275244020004	The hoop	内抱箍	2		
9	911200100006	Oil cup DIN71412A - M8x1	油杯DIN71412A-M8x1	2		
10	910100300022	Bolt GB5783 M8x20-8.8	螺栓GB5783-M8x20-8.8	4		
11	271544010002	With trunnion Φ x50 25	带耳轴 Φ 25x50	2		
12	271544010003	Tie rod	拉杆	1		
13	271544010001	With trunnion Φ 30 x86	带耳轴 Φ 30x86	2		
14	940800600004	Embrace hoop Φ 80 components	抱箍组件 Φ 80	1		
15	271543512001	Inner mast (2500)	内门架焊合(2500)	1	H=2500	
	271543512002	Inner mast (2700)	内门架焊合(2700)	1	H=2700	
	271543512003	Inner mast (3000)	内门架焊合(3000)	1	H=3000	
	271543512004	Inner mast (3300)	内门架焊合(3300)	1	H=3300	
	271543512005	Inner mast (3500)	内门架焊合(3500)	1	H=3500	
	271543512006	Inner mast (3700)	内门架焊合(3700)	1	H=3700	
271543512007	Inner mast (4000)	内门架焊合(4000)	1	H=4000		
16	271543511001	Outer mast (2500)	外门架焊合(2500)	1	H=2500	
	271543511002	Outer mast (2700)	外门架焊合(2700)	1	H=2700	
	271543511003	Outer mast (3000)	外门架焊合(3000)	1	H=3000	
	271543511004	Outer mast (3300)	外门架焊合(3300)	1	H=3300	
	271543511005	Outer mast (3500)	外门架焊合(3500)	1	H=3500	
	271543511006	Outer mast (3700)	外门架焊合(3700)	1	H=3700	
271543511007	Outer mast (4000)	外门架焊合(4000)	1	H=4000		
17	940200300003	Composite roller Φ 70.6 = 43.5-47.5	复合滚轮 Φ 70.6-range=43.5-47.5	4		
18	910401300020	Axis with elastic catch GB894.1-40	轴用弹性挡圈GB894.1-40	4		
19	▲	Plate chain GB6074 - LH1044	板式链GB6074-LH1044	1		
20	940200500014	Sprocket wheel bearing 90 X 780/03- Φ 25 x31	链轮轴承780/03- Φ 90X Φ 35X21	1		

门架（二级全自由门架）/Mast (two-stage full free mast)						
序号/NO	编码/SN	Name	名称	数量/QTY	备注/Remark	
21	271544520002	Sprocket washer	链轮垫圈	2		
22	271544520108	Pin 6 x30 Φ	销轴 Φ 6x30	2		
23	532343020024	Chain bolt m16x1.5x129	链条螺栓M16x1.5x129	1		
24	910600600030	Cotter pin GB91-3.2 x	开口销GB91-3.2x30	3		
25	910300200008	Nut GB6171 - M16x1. 5-10	螺母GB6171-M16x1.5-10	1		
26	254144020066	Spherical nut m16x1.5	球面螺母M16x1.5	1		
A	271543515001	Lifting chain lh1044-71	起升链条LH1044-71	1	H=2500	
	271544515002	Lifting chain lh1044-75	起升链条LH1044-75	1	H=2700	
	271543515002	Lifting chain lh1044-79	起升链条LH1044-79	1	H=3000	
	271544515004	Lifting chain lh1044-81	起升链条LH1044-81	1	H=3300	
	271544515005	Lifting chain lh1044-83	起升链条LH1044-83	1	H=3500	
	271543515003	Lifting chain lh1044-91	起升链条LH1044-91	1	H=3700	
271544515007	Lifting chain lh1044-95	起升链条LH1044-95	1	H=4000		

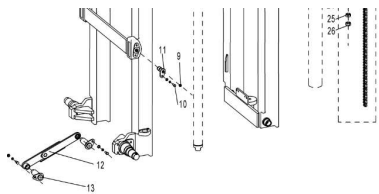

门架（三级全自由门架）/Mast (three-stage full free mast)

序号/NO	编码/SN	Name	名称	数量/QTY	备注/Remark
1	271544010003	Tie rod	拉杆	1	
2	910400500007	Spring washer GB93-10	弹簧垫圈GB93-10	2	
3	910400200004	Big washer GB96.1-10-200 HV	大垫圈GB96.1-10-200HV	2	
4	910100300035	Bolt GB5783 M10x20-8.8	螺栓GB5783-M10x20-8.8	2	
5	271544010001	With trunnion Φ 30 x86	带耳轴Φ30x86	2	
6	271544511001	Outer mast (4000)	外门架焊合(4000)	1	H=4000
	271544511002	Outer mast(4350)	外门架焊合(4350)	1	H=4350
	271544511003	Outer mast (4500)	外门架焊合(4500)	1	H=4500
	271544511004	Outer mast (4800)	外门架焊合(4800)	1	H=4800
	271544511005	Outer mast (5000)	外门架焊合(5000)	1	H=5000
7	940200300003	Composite roller Φ 70.6 = 43.5-47.5	复合滚轮Φ70.6-range=43.5-47.5	4	
8	910401300020	Axis with elastic catch GB894.1-40	轴用弹性挡圈GB894.1-40	2	
9	275244020004	The hoop	内抱箍	2	
10	275244020003	The hoop	外抱箍	2	
11	271544010002	With trunnion Φ x50 25	带耳轴Φ25x50	2	
12	910400500006	Spring washer GB93-8	弹簧垫圈GB93-8	16	
13	910400100006	The flat washer GB97.1-8-200 HV	平垫圈GB97.1-8-200HV	16	
14	910100300022	Bolt GB5783 M8x20-8.8	螺栓GB5783-M8x20-8.8	12	
15	910400500008	Spring washer GB93-12	弹簧垫圈GB93-12	3	
16	910400100008	The flat washer GB97.1-12-200 HV	平垫圈GB97.1-12-200HV	3	
17	910100300052	Bolt GB5783 M12x40-8.8	螺栓GB5783-M12x40-8.8	2	
18	271544513001	Middle mast (4000)	中门架焊合(4000)	1	H=4000
	271544513002	Middle mast (4350)	中门架焊合(4350)	1	H=4350
	271544513003	Middle mast (4500)	中门架焊合(4500)	1	H=4500
	271544513004	Middle mast (4800)	中门架焊合(4800)	1	H=4800
	271544513005	Middle mast (5000)	中门架焊合(5000)	1	H=5000
19	940200500005	Sprocket wheel bearing 782208 x 782208 φ40x21.40	链轮轴承782208-φ70xφ40x21	2	
20	271544020108	Pin 6 x28 Φ	销轴Φ6x28	2	
21	910600600030	Cotter pin GB91-3.2 x	开口销GB91-3.2x30	2	
22	271544020107	Chain bolt M16x1.5x142.5	链条螺栓M16x1.5x142.5	1	
23	910300200008	Nut GB6171 - M16x1. 5-10	螺母GB6171-M16x1.5-10	2	
24	▲	Plate chain GB6074 - LH1034	板式链GB6074-LH1034	1	

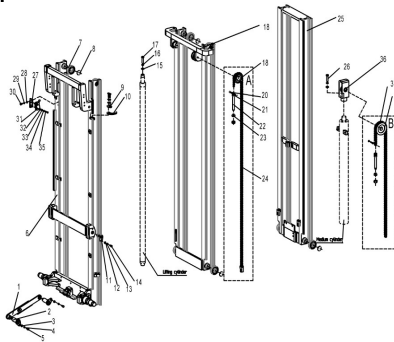

门架（三级全自由门架）/Mast (three-stage full free mast)

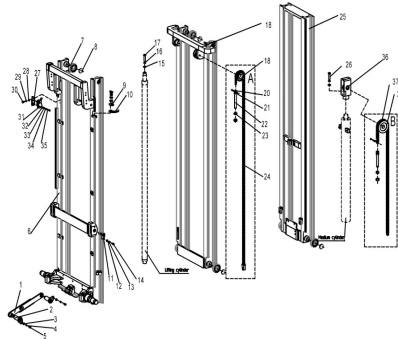

序号/NO	编码/SN	Name	名称	数量/QTY	备注/Remark
A	271544514001	Lifting chain lh1034-107	起升链条LH1034-107	2	H=4000
	271544514002	Lifting chain lh1034-114	起升链条LH1034-114	2	H=4350
	271544514003	Lifting chain lh1034-117	起升链条LH1034-117	2	H=4500
	271544514004	Lifting chain lh1034-123	起升链条LH1034-123	2	H=4800
	271544514005	Lifting chain lh1034-129	起升链条LH1034-129	2	H=5000
25	271544512001	Inner mast(4000)	内门架焊合(4000)	1	H=4000
	271544512002	Inner mast (4350)	内门架焊合(4350)	1	H=4350
	271544512003	Inner mast (4500)	内门架焊合(4500)	1	H=4500
	271544512004	Inner mast (4800)	内门架焊合(4800)	1	H=4800
	271544512005	Inner mast (5000)	内门架焊合(5000)	1	H=5000
26	910100300050	Bolt GB5783 M12x30-8.8	螺栓GB5783-M12x30-8.8	1	
27	271544020006	Mounting plate (limit switch)	安装板(限位开关)	1	
28	910400500005	Spring washer GB93-6	弹簧垫圈GB93-6	2	
29	910400100005	Flat washer GB97.1-6-200 HV	平垫圈GB97.1-6-200HV		
30	910100300009	Bolt GB5783 M6x12-8.8	螺栓GB5783-M6x12-8.8	2	
31	920200300003	Micro switch rz-15gw2s-b3	微动开关RZ-15GW2S-B3	1	
32	910300100005	Nut GB6170 - M6-10	螺母GB6170-M6-10	2	
33	910400500005	Spring washer GB93-6	弹簧垫圈GB93-6	2	
34	910400100004	Flat washer GB97.1-5-200 HV	平垫圈GB97.1-5-200HV	2	
35	910201200001	Screw GB71 M6x20-45 h	螺钉GB71-M6x20-45H	2	
36	271544520003	Sprocket wheel rack	链轮架	1	
37	▲	Plate chain GB6074 - LH1044	板式链GB6074-LH1044	1	
38	940200500014	Sprocket wheel bearing 90 x 780/03	链轮轴承780703-Φ90XΦ35X21	1	
B	271544515001	Lifting chain lh1044-77	起升链条LH1044-73	1	H=4000
	271544515002	Lifting chain lh1044-77	起升链条LH1044-81	1	H=4350
	271544515003	Lifting chain lh1044-81	起升链条LH1044-77	1	H=4500
	271544515004	Lifting chain lh1044-83	起升链条LH1044-81	1	H=4800
	271544515005	Lifting chain lh1044-89	起升链条LH1044-89	1	H=5000

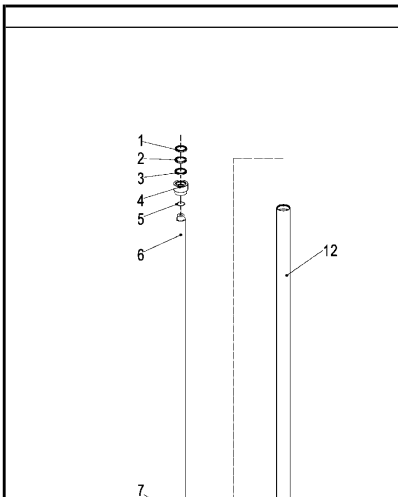

起升油缸 (标准门架) /Lifting cylinder (standard mast)					
序号/NO	编码/SN	Name	名称	数量/QTY	备注/Remark
A	271544016001	Oil cylinder Φ 40 xΦ35 x1245	油缸(H=2500)	2	H=2500
	271544016002	Oil cylinder Φ 40 xΦ35 x1345	油缸(H=2700)	2	H=2700
	271544016003	Oil cylinder Φ 40 xΦ35 x1495	油缸(H=3000)	2	H=3000
	271544016004	Oil cylinder Φ 40 xΦ35 x1645	油缸(H=3300)	2	H=3300
	271544016005	Oil cylinder Φ 40 xΦ35 x1745	油缸(H=3500)	2	H=3500
	271544016006	Oil cylinder Φ 40 xΦ35 x1845	油缸(H=3700)	2	H=3700
271544016007	Oil cylinder Φ 40 xΦ35 x1995	油缸(H=4000)	2	H=4000	
1	▲	DH35x43x5x6. 5	DH35	1	
2	▲	Catch 35 x45x3	挡片 35x45x3	1	
3	▲	Shaft with 35 x45x6	轴用密封圈	1	
4	▲	Cylinder head	缸盖	1	
5	▲	O-rings D45x3. 1	O型圈	1	
6	▲	The piston rod	活塞杆	1	
7	▲	spring	弹簧	1	
8	▲	Buffer core	缓冲芯	1	
9	▲	The piston	活塞	1	
10	▲	Guide screw	导向螺钉	1	
11	▲	Bearing ring C35X40X14	支承环 C35X40X14	1	
12	▲	cylinder	缸筒	1	
13	▲	o-rings	O型圈	1	
14	▲	Explosion-proof valve	防爆阀	1	

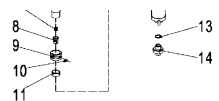

A	271598510001	Seal package	密封包(起升油缸)	2	包含/Inc.1.3.5.11.13

短升降油缸 (二级全自由) /Short lift cylinder (two-stage full free mast)

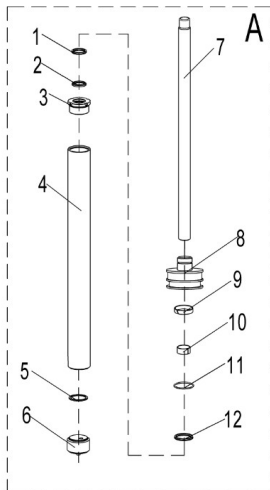

序号/NO	编码/SN	Name	名称	数量/QTY	备注/Remark
A	271543518001	Oil cylinder (M) Φ 76 x Φ 63 x497	油缸(M)(H=2500)	1	H=2500
	271543518002	Oil cylinder (M) Φ 76 x Φ 63x597	油缸(M)(H=2700)	1	H=2700
	271543518003	Oil cylinder (M) Φ 76 x Φ 63 x747	油缸(M)(H=3000)	1	H=3000
	271543518004	Oil cylinder (M) Φ 76 x Φ 63 x897	油缸(M)(H=3300)	1	H=3300
	271543518005	Oil cylinder (M) Φ 76 x Φ 63 x997	油缸(M)(H=3500)	1	H=3500
	271543518006	Oil cylinder (M) Φ 76 x Φ 63 x1097	油缸(M)(H=3700)	1	H=3700
	271543518007	Oil cylinder (M) Φ 76 x Φ 63 x1247	油缸(M)(H=4000)	1	H=4000
1	▲	Shaft with 40 x 50 x 6 _11	防尘圈	1	
2	▲	DH40 x 48 x 5 x 6.5	密封圈	1	
3	▲	Built-in cylinder head	内置缸盖	1	
4	▲	Built-in cylinder	内置缸筒	1	
5	▲	53 x63x3 block slice	挡片53X63X3	1	
6	▲	The bottom right	右缸底	1	
7	▲	The piston rod	活塞杆	1	
8	▲	The piston	活塞	1	
9	▲	Bearing ring 58 x63x13	支承环58X63X13	1	
10	▲	Steel back bearing 40X44X20	钢背轴承40X44X20	1	
11	▲	O-rings D68X3_1	O型圈	1	
12	▲	Hole with 53 * 63 * 6 _11	孔用密封圈	1	
A	271598510002	Seal repair kit (middle cylinder)	密封件修理包(中间缸)	1	包含/Inc1.2.9.11.12

起升油缸 (二级全自由) /Lift cylinder (two-stage full free mast)

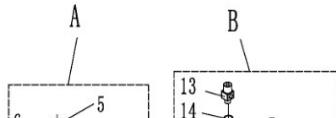

序号/NO	编码/SN	Name	名称	数量/QTY	备注/Remark
A	271543516001	Oil cylinder (R) Φ 40 x Φ 30 x1245	油缸(R)(H=2500)	1	H=2500
	271543516002	Oil cylinder (R) Φ 40 x Φ 30 x1345	油缸(R)(H=2700)	1	H=2700
	271543516003	Oil cylinder (R) Φ 40 x Φ 30 x1495	油缸(R)(H=3000)	1	H=3000
	271543516004	Oil cylinder (R) Φ 40 x Φ 30 x1645	油缸(R)(H=3300)	1	H=3300
	271543516005	Oil cylinder (R) Φ 40 x Φ 30 x1745	油缸(R)(H=3500)	1	H=3500

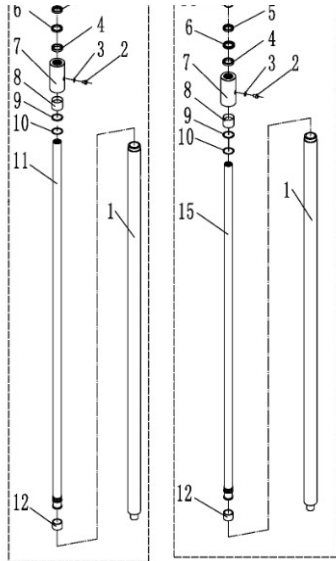

	271543516006	Oil cylinder (R) Φ 40 x Φ 30 x1845	油缸(R)(H=3700)	1	H=3700
	271543516007	Oil cylinder (R) Φ 40 x Φ 30 x1995	油缸(R)(H=4000)	1	H=4000
B	271543517001	Oil cylinder (L) Φ 40 x Φ 30 x1245	油缸(L)(H=2500)	1	H=2500
	271543517002	Oil cylinder (L) Φ 40 x Φ 30 x1345	油缸(L)(H=2700)	1	H=2700
	271543517003	Oil cylinder (L) Φ 40 x Φ 30 x1495	油缸(L)(H=3000)	1	H=3000
	271543517004	Oil cylinder (L) Φ 40 x Φ 30 x1645	油缸(L)(H=3300)	1	H=3300
	271543517005	Oil cylinder (L) Φ 40 x Φ 30 x1745	油缸(L)(H=3500)	1	H=3500
	271543517006	Oil cylinder (L) Φ 40 x Φ 30 x1845	油缸(L)(H=3700)	1	H=3700
	271543517007	Oil cylinder (L) Φ 40 x Φ 30 x1995	油缸(L)(H=4000)	1	H=4000
1	▲	Cylinder block	缸体	2	
2	▲	Hexagon socket head screw	内六角圆柱头螺钉	2	
3	▲	Combination gasket	组合密封垫圈	2	
4	▲	Shaft seal 30 x40x6	轴封30X40X6	2	
5	▲	DH30X38X5	DH30X38X5	2	
6	▲	Retaining ring	挡圈	2	
7	▲	Cylinder head	缸盖	2	
8	▲	Steel back bearing 30X34X25	钢背轴承30X34X25	2	
9	▲	O-rings D45X3. 1	O型圈	2	
10	▲	Retaining ring	挡圈	2	
11	▲	Right the piston rod	右活塞杆	1	
12	▲	Supporting ring for bore 35X40X10	孔用支承环35X40X10	2	
13	▲	The left cylinder joint	左缸接头	1	
14	▲	O-ring rubber	O形橡胶密封圈	1	
15	▲	Left the piston rod	左活塞杆	1	
16	▲	Steel body	钢体	1	
A	271598510003	Seal repair kit (lifting cylinder)	密封件修理包(起升缸)	2	包含/Inc.4.5.9.12.14

短升降油缸 (三级全自由) / Short lift cylinder (three-stage full free mast)

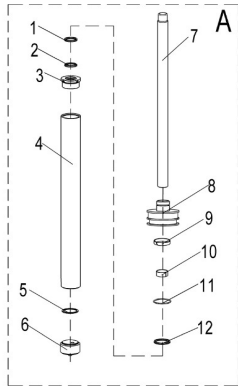

序号/NO	编码/SN	Name	名称	数量/QTY	备注/Remark
A	271544518001	Oil cylinder (M) Φ 56 x Φ 45 x497	油缸(M)(H=4000)	1	H=4000
	271544518002	Oil cylinder (M) Φ 56 x Φ 45 x597	油缸(M)(H=4350)	1	H=4350
	271544518003	Oil cylinder (M) Φ 56 x Φ 45x 747	油缸(M)(H=4500)	1	H=4500
	271544518004	Oil cylinder (M) Φ 56 x Φ 45 x897	油缸(M)(H=4500)	1	H=4800
	271544518005	Oil cylinder (M) Φ 56 x Φ 45 x997	油缸(M)(H=5000)	1	H=5000
1	▲	Shaft with 45 * 55 * 6	轴用45×55×6	1	
2	▲	DH45 53 x 5 x 6.5 x	DH45×53×5×6.5	1	
3	▲	Built-in cylinder head	内置缸盖	1	
4	▲	Built-in cylinder	内置缸筒	1	
5	▲	53 x63x3 block slice	挡片53X63X3	1	
6	▲	The bottom right	右缸底	1	
7	▲	The piston rod	活塞杆	1	
8	▲	The piston	活塞	1	
9	▲	51 x56x20 bearing ring	支承环51X56X20	1	
10	▲	Steel back bearing 45X49X30	钢背轴承45X49X30	1	
11	▲	O-rings D60X3. 1	o型圈D60X3.1	1	
12	▲	Hole with 45 * 56 * 7	孔用45×56×7	1	
A	271598510004	Seal repair kit (middle cylinder)	密封件修理包(中间缸)	1	包含/Inc.1.2.9.11.12

起升油缸(三级全自由) /Lifting cylinder(three-stage full free mast)

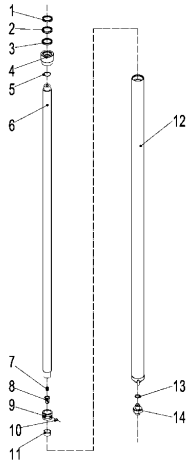

序号/NO	编码/SN	Name	名称	数量/QTY	备注/Remark
A	271544516001	Oil cylinder Φ 35 xΦ40 x1295	油缸(H=4000)	2	H=4000
	271544516002	Oil cylinder Φ 35 xΦ40 x1425	油缸(H=4350)	2	H=4350
	271544516003	Oil cylinder Φ 35 xΦ40 x1475	油缸(H=4500)	2	H=4500
	271544516004	Oil cylinder Φ 35 xΦ40 x1575	油缸(H=4500)	2	H=4800
	271544516005	Oil cylinder Φ 35 xΦ40 x1625	油缸(H=5000)	2	H=5000
1	▲	DH35x43x5x6. 5	DH35	1	
2	▲	Catch 35 x45x3	挡片 35x45x3	1	
3	▲	Shaft with 35 x45x6	轴用35	1	
4	▲	Cylinder head	缸盖	1	
5	▲	O-rings D45x3. 1	O型圈	1	
6	▲	The piston rod	活塞杆	1	
7	▲	spring	弹簧	1	
8	▲	Buffer core	缓冲芯	1	
9	▲	The piston	活塞	1	
10	▲	Guide screw	导向螺钉	1	
11	▲	Bearing ring C35X40X14	支承环C35X40X14	1	
12	▲	cylinder	缸筒	1	
13	▲	o-rings	O型圈	1	
14	▲	Explosion-proof valve	防爆阀	1	
A	271598510001	Seal repair kit	密封件修理包(起升油缸)	2	包括/Inc1.3.5.11.13

倾斜油缸/Tilting cylinder

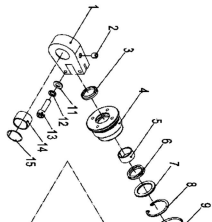

序号/NO	编码/SN	Name	名称	数量/QTY	备注/Remark
A	271520511001	Tilting cylinder	倾斜油缸	1	H<4000
	271520511002	Tilting cylinder	倾斜油缸	1	H≥4000
1	▲	GIHR - K30D0 earrings 2	GIHR-K30D0耳环2	1	
2	▲	Straight through type pressure injector nozzle M10	直通式压注油嘴M10	1	
3	▲	5 x6 DH28x36x4.	DH28	1	
4	▲	Guide sleeve	导向套	1	
5	▲	Steel back bearing 28x32x15	钢背轴承28x32x15	1	
6	▲	DH28x36x6	DH28x36x6	1	
7	▲	Block slice 28 x38x3	挡片 28x38x3	1	
8	▲	Retaining ring 47	挡圈47	1	
9	▲	O-rings d60x3. 55	O型圈	1	

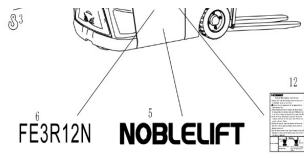

10	941200100004	Label (stacked warning)	标贴(堆高组合警示)	2	
11	255047020019	The vehicle assembly	整车吊装	1	
12	255047020007	Battery maintenance tips	蓄电池保养提示	1	

数据铭牌(中文)

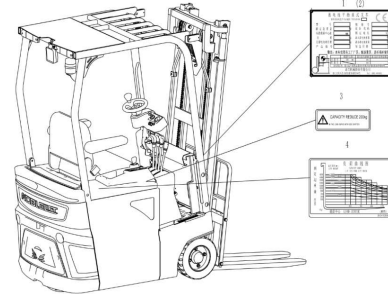

序号/NO	编码/SN	Name	名称	数量/QTY	备注/Remark
1	255047520001		铭牌(中文)	1	
2	910500600002		铆钉GB827-3x10	4	
3	255047520004		带侧移减重标贴	1	
4	271547520003		载荷曲线(贴纸)	1	

数据铭牌(英文)/Data nameplate

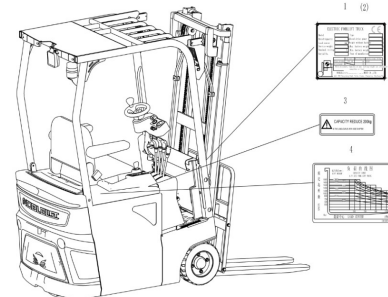

序号/NO	编码/SN	Name	名称	数量/QTY	备注/Remark
1	255047520002	nameplate	铭牌(英文)	1	
2	910500600002	Rivet GB827-3 x10	铆钉GB827-3x10	4	
3	255047520005	Label with side shift minus weight	带侧移减重标贴	1	
4	271547520003	Load curve (sticker)	载荷曲线(贴纸)	1	

电气系统/Electrical system

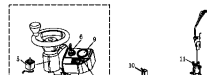

序号/NO	编码/SN	Name	名称	数量/QTY	备注/Remark
1	920200300009	Micro switch	微动开关	1	Parking brake
2	910400100003	The flat washer GB97.1-4-200 HV	平垫圈GB97.1-4-200HV	2	
3	922000100001	Lamp PDL - LXZM - 1	灯PDL-LXZM-1	2	headlamp
4	922000100002	Lamp PDL - LXXD - 1	灯PDL-LXXD-1	2	front turn signal lamp
5	921800200004	Potentiometer TY1204-1	电位器	1	Curtis
	921800200005	Potentiometer 23KM-K227-06V	电位器	1	Zapi
6	920200200002	Key switch	钥匙开关	1	
7	920200800018	Rocker switch YB-nuoli-001	翘板开关YB-nuoli-001	1	

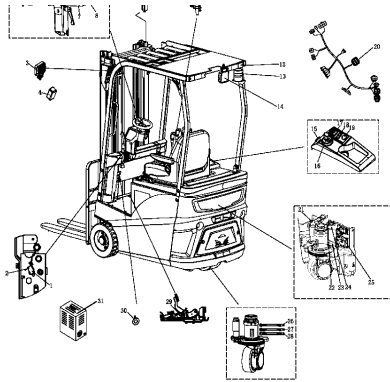

8	92020070003	Button switch gq16h-10	按钮开关GQ16H-10	1		
9	921100100038	Instrument 8 3140-12-4 v	仪表3140-12-48V	1	Curtis	
	921100100047	Instrument D13L-A	仪表D13L-A	1	Zapi	
10	920200300003	Micro switch rz-15gw2s-b3	微动开关RZ-15GW2S-B3	1		
11	920200300004	Micro switch rz-15gq22-b3	微动开关RZ-15GQ22-B3	1		
12	922000100003	Lamp PDL - LXHW - 2	灯PDL-LXHW-2	2	rear combination	
13	922000100004	Lamp PDL - LXJD - 01 y	灯PDL-LXJD-01Y	1	caution light	
14	922000100001	Lamp PDL - LXZM - 1	灯PDL-LXZM-1	1	选装/Optional	
	922000100014	Lamp A-LJD-A1	灯A-LJD-A1	1	选装/Optional	
15	920200100020	Emergency stop switch	急停开关	1		
16	920200800018	Rocker switch YB-nuoli-001	翘板开关YB-nuoli-001	1		
17	920200800021	Tilt-plate switch yb-nuol-004	翘板开关YB-nuoli-004	1		
18	920200800020	Tilt-plate switch yb-nuol-003	翘板开关YB-nuoli-003	1		
19	921900100004	Converter DC24V to 5V	转换器DC24V转5V	1	选装/Optional	
20	271133010001	Body wiring harness (Curtis-3R08N)	车身线束(Curtis-3R08N)	1	FE3R08-10N	
	271133010003	Body wiring harness (Zapi-3R08N)	车身线束(Zapi-3R08N)	1		
	271533010001	Body wiring harness (Curtis-3R12N)	车身线束(Curtis-3R12N)	1	FE3R12N	
	271533010012	Body wiring harness (Zapi-3R12N)	车身线束(Zapi-3R12N)	1		
21	271533010010	Mains harness	总电源线束	1		
22	922000100005	Lights SG252 -24 v	灯SG252-24V	1		
23	920200400008	Approach switch Fi4-M12-OP6L-L70PNP	接近开关Fi4-M12-OP6L-L70PNP	1	08/10 Curtis用	
	920200400007	Approach switch Fi4-M12-ON6L-L70	接近开关Fi4-M12-ON6L-L70	1	FE3R08-10N Zapi	
	920200400012	Approach switch Fi5-Q18-OP6L	接近开关Fi5-Q18-OP6L	1	FE3R12N Curtis	
	920200400011	Approach switch Fi4-G12-ON6L	接近开关Fi4-G12-ON6L	1	FE3R12N Zapi	
24	920500100002	Speaker buzzer dJB-24b	喇叭蜂鸣器DJB-24B	1		
25	271133010002	Electronic control module (Curtis-3R08N)	电控组件(Curtis-3R08N)	1	FE3R08-10N	
	271133010011	Electronic control module (Zapi-3R08N)	电控组件(Zapi-3R08N)	1		
	271533010002	Electronic control module (Curtis-3R12N)	电控组件(Curtis-3R12N)	1	FE3R12N	
	271533010011	Electronic control module (Zapi-3R12N)	电控组件(Zapi-3R12N)	1		
26	271533010003	Cable - U1 - the 25-6-8-400	线缆-U1-25-6-8-400	1		
27	271533010004	Cable - V1 - the 25-6-8-400	线缆-V1-25-6-8-400	1		
28	271533010005	Cable - W1-25-6-8-400	线缆-W1-25-6-8-400	1		
29	920500100001	The horn 125 - DC24V	喇叭125-DC24V	1		
30	920201000002	Foot switch	脚踏开关	1		
31	921000200381	Charger SN24V35A(Asian Chinese)	充电器SN24V35A(亚中)	1	280Ah	
	921000200382	Charger SN24V35A(Asian English)	充电器SN24V35A(亚英)	1	280Ah	
	921000200383	Charger SN24V35A(Europe)	充电器SN24V35A(欧)	1	280Ah	
	921000200384	Charger SN24V35A(Britain)	充电器SN24V35A(英)	1	280Ah	
	921000200385	Charger SN24V35A(Australia)	充电器SN24V35A(澳)	1	280Ah	
	921000200386	Charger SN24V35A(USA)	充电器SN24V35A(美)	1	280Ah	
	921000200031	Charger SN24V55A(Asian Chinese)	充电器SN24V55A(亚中)	1	360、400Ah	
	921000200032	Charger SN24V55A(Asian English)	充电器SN24V55A(亚英)	1	360、400Ah	
	921000200033	Charger SN24V55A(Europe)	充电器SN24V55A(欧)	1	360、400Ah	
	921000200034	Charger SN24V55A(Australia)	充电器SN24V55A(澳)	1	360、400Ah	
	921000200035	Charger SN24V55A(Britain)	充电器SN24V55A(英)	1	360、400Ah	
	921000200036	Charger SN24V55A(USA)	充电器SN24V55A(美)	1	360、400Ah	
	921000200073	Charger SN24V60A(Asian Chinese)	充电器SN24V60A(亚中)	1	420、480Ah	
	921000200074	Charger SN24V60A(Asian English)	充电器SN24V60A(亚英)	1	420、480Ah	
	921000200075	Charger SN24V60A(Europe)	充电器SN24V60A(欧)	1	420、480Ah	
	921000200076	Charger SN24V60A(Australia)	充电器SN24V60A(澳)	1	420、480Ah	
	921000200077	Charger SN24V60A(Britain)	充电器SN24V60A(英)	1	420、480Ah	
	921000200078	Charger SN24V60A(USA)	充电器SN24V60A(美)	1	420、480Ah	
	31	921000200061	Charger SN24V80A(Asian Chinese)	充电器SN24V80A(亚中)	1	540、600Ah
		921000200062	Charger SN24V80A(Asian English)	充电器SN24V80A(亚英)	1	540、600Ah
921000200063		Charger SN24V80A(Europe)	充电器SN24V80A(欧)	1	540、600Ah	
921000200064		Charger SN24V80A(Australia)	充电器SN24V80A(澳)	1	540、600Ah	
921000200065		Charger SN24V80A(Britain)	充电器SN24V80A(英)	1	540、600Ah	
921000200066		Charger SN24V80A(USA)	充电器SN24V80A(美)	1	540、600Ah	

FE3R08-10 电控组件(Curtis) / FE3R08-10 Electronic components (Curtis)

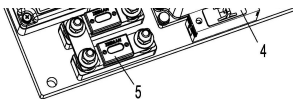

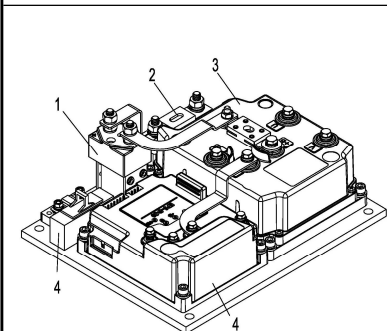

FE3R12电控组件(Zapi) / FE3R12 Electronic components (Zapi)					
序号/NO	编码/SN	Name	名称	数量/QTY	备注/Remark
1	920700100002	Contactor DC24V-SW180B-4	接触器	1	
2	920100100008	Fuse 200A	保险丝200A(塑料)	2	
3	271598033004	Controller ACEX24V-240A(3R12N-T)	控制器ACEX24V-240A (3R12N-T)	1	
4	271598033005	Controller EPS-DCU-24V-50A(3R12N-T)	控制器EPS-DCU-24V-50A (3R12N-T)	1	
5	271533011005	Safety seat RT14-20 10A	保险座RT14-20 10A	1	

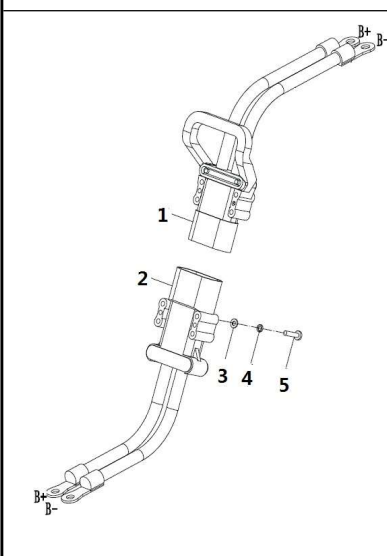

电源连接器总成/Power connector assembly					
序号/NO	编码/SN	Name	名称	数量/QTY	备注/Remark
1	920400100014	Batteryconnecting cable REMA95017-	接插件REMA95017-01	1	Plumbic acid/铅酸
	920400100022	Batteryconnecting cable REMA95016-	接插件REMA95016-32	1	LI/锂电
2	920400100011	Batteryconnecting cable REMA95044-	接插件REMA95044-01	1	Plumbic acid/铅酸
	920400100021	Batteryconnecting cable REMA95043-	接插件REMA95043-39	1	LI/锂电
3	910400100005	Washer GB97.1-6-200HV	平垫圈GB97.1-6-200HV	4	
4	910400500005	Spring washer GB93-6	弹簧垫圈GB93-6	4	
5	910200200046	Screw GB70.1-M6x60-8.8	螺钉GB70.1-M6x60-8.8	4	

蓄电池/Battery and bracket					
序号/NO	编码/SN	Name	名称	数量/QTY	备注/Remark

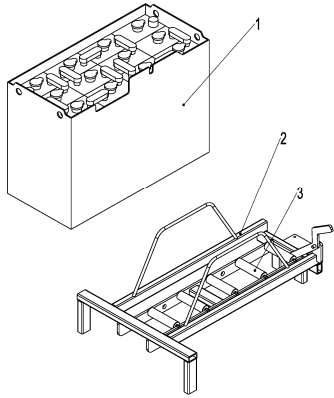

1	271537010001	Battery24V-6PzS420(Welding gold happy)	牵引电池24V-6PzS420(焊)(标配内销)	1	FE3R10-12N	
	271537010002	Battery24V-6PzS420(Bolt gold happy)	牵引电池24V-6PzS420(螺)(标配外销)	1	FE3R10-12N	
	271537010003	Battery24V-6PzS420(Welding huojju)	牵引电池24V-6PzS420(焊)	1	FE3R10-12N	
	271537010004	Battery24V-6PzS420(Bolt huojju)	牵引电池24V-6PzS420(螺)	1	FE3R10-12N	
	271537010005	Battery24V-6PzS480(Welding gold happy)	牵引电池24V-6PzS480(焊)	1	FE3R10-12N	
	271537010006	Battery24V-6PzS480(Bolt gold happy)	牵引电池24V-6PzS480(螺)	1	FE3R10-12N	
	271537010007	Battery24V-6PzS480(Welding huojju)	牵引电池24V-6PzS480(焊)	1	FE3R10-12N	
	271537010008	Battery24V-6PzS480(Bolt huojju)	牵引电池24V-6PzS480(螺)	1	FE3R10-12N	
	271537010009	Battery24V-6PzS540(Welding gold happy)	牵引电池24V-6PzS540(焊)	1	FE3R10-12N	
	271537010010	Battery24V-6PzS540(Bolt gold happy)	牵引电池24V-6PzS540(螺)	1	FE3R10-12N	
	271537010011	Battery24V-6PzS540(Welding huojju)	牵引电池24V-6PzS540(焊)	1	FE3R10-12N	
	271537010012	Battery24V-6PzS540(Bolt huojju)	牵引电池24V-6PzS540(螺)	1	FE3R10-12N	
	271537010013	Battery24V-6PzS600(Welding gold happy)	牵引电池24V-6PzS600(焊)	1	FE3R10-12N	
	271537010014	Battery24V-6PzS600(Bolt gold happy)	牵引电池24V-6PzS600(螺)	1	FE3R10-12N	
	271537010015	Battery24V-6PzS600(Welding huojju)	牵引电池24V-6PzS600(焊)	1	FE3R10-12N	
1	271137010001	Battery24V-6PzS280(Welding gold happy)	牵引电池24V-6PzS280(焊)(标配内销)	1	FE3R08N	
	271137010002	Battery24V-6PzS280(Bolt gold happy)	牵引电池24V-6PzS280(螺)(标配外销)	1	FE3R08N	
	271137010003	Battery24V-6PzS280(Welding huojju)	牵引电池24V-6PzS280(焊)	1	FE3R08N	
	271137010004	Battery24V-6PzS280(Bolt huojju)	牵引电池24V-6PzS280(螺)	1	FE3R08N	
	271137010005	Battery24V-6PzS360(Welding gold happy)	牵引电池24V-6PzS360(焊)	1	FE3R08N	
	271137010006	Battery24V-6PzS360(Bolt gold happy)	牵引电池24V-6PzS360(螺)	1	FE3R08N	
	271137010007	Battery24V-6PzS360(Welding huojju)	牵引电池24V-6PzS360(焊)	1	FE3R08N	
	271137010008	Battery24V-6PzS360(Bolt huojju)	牵引电池24V-6PzS360(螺)	1	FE3R08N	
	271137010009	Battery24V-6PzS420(Welding gold happy)	牵引电池24V-6PzS420(焊)	1	FE3R08N	
	271137010010	Battery24V-6PzS420(Bolt gold happy)	牵引电池24V-6PzS420(螺)	1	FE3R08N	
	271137010011	Battery24V-6PzS420(Welding huojju)	牵引电池24V-6PzS420(焊)	1	FE3R08N	
	271137010012	Battery24V-6PzS420(Bolt huojju)	牵引电池24V-6PzS420(螺)	1	FE3R08N	
	1	271137012101	Lithium battery 24V-200(JN-A)	锂电池24V-200(JN-A)	1	FE3R08N
		271137012102	Lithium battery 24V-250(JN-A)	锂电池24V-250(JN-A)	1	FE3R08N
		271137012103	Lithium battery 24V-300(JN-A)	锂电池24V-300(JN-A)	1	FE3R08N
271537012101		Lithium battery 24V-300(JN-A)	锂电池24V-300(JN-A)	1	FE3R10-12N	
1	271537012102	Lithium battery 24V-350(JN-A)	锂电池24V-350(JN-A)	1	FE3R10-12N	
	271537012103	Lithium battery 24V-400(JN-A)	锂电池24V-400(JN-A)	1	FE3R10-12N	
	271537012104	Lithium battery 24V-450(JN-A)	锂电池24V-450(JN-A)	1	FE3R10-12N	
2	271512511001	Battery bracket	电池托架焊合	1	FE3R10-12N	
	271112511001	Battery bracket	电池托架焊合	1	FE3R08N	
3	271521511010	Roller suite	滚轮套件	1		