

NOBLELIFT



Scan QR Code for More

Service Hotline: 836115

Electric Pallet Truck PTE20Q

PARTS MANUAL

509946020104

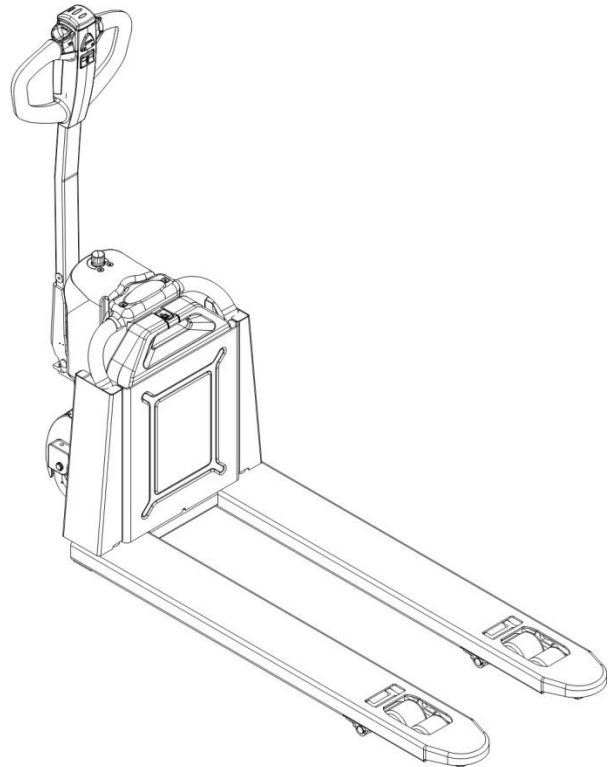

Version: V03

Truck Identification Number From:

Parts Manual

PTE20Q-B-PM03EN

Please order spare parts from authorized dealers of Noblelift Intelligent Equipment Co., LTD.

In order to avoid wrong delivery, all the orders for spare parts should specify the following items:

- Truck model, identification number and manufacture year.
- Orders for spare parts of mast, hydraulic transmission unit, steering axle, motor, etc. shall indicate the manufacture number of these parts.
- Codes for Noblelift spare parts are shown in the table of parts manual. Please also pay attention to the description of supply status, order quantity, etc. (check the number listed in "Mark" column of the parts manual).

"Mark" Column:

The unmarked indicates the parts are in short supply cycle.

Number 1: supply as package. Indicating these that parts are small parts and seal parts, which are supplied in package unit and in short supply cycle.

Number 2: supply with constraints. Indicating that these spare parts are not in stock and will be prepared for production after receiving the order from customers, which are in long supply cycle.

Number 3: phasing-out supply. Indicating that these parts will be replaced by new parts due to technical improvements and the current stock will not be available when these parts run out. Please check the description of technical improvements notice.

Number 4: supply as assembly. Indicating that these parts are assembly parts defined by manufacture process, which cannot be supplied as a single part.

Number 5: check other tables.

This parts manual is the property of Noblelift and can be shared under the confidential agreement only, Noblelift has the right to claim for compensation of any unauthorized use. Copy without permission is not allowed. Figures in the manual are not limited by the original design. Noblelift Intelligent Equipment Co., LTD reserves the right to improve the products for continuous technology progress.

Table of Contents

Chapter 1: Drive System.....	4
01 Drive Unit Steering(20Q)(509946013502)	4
02 Drive Assembly(20Q)(509946013003).....	6
Chapter 2: Hydraulic System.....	8
01 Hydraulic Components(20Q)(509946023504)	8
02 Hydraulic Components (EN1175-2020)(509946023504)	10
Chapter 3: Truck Frame	12
01 Truck Frame (509946038501).....	12
02 Truck Frame (509946038502).....	14
02 Truck Frame (509946038502) Continuation.....	16
Chapter 4: Steering System, Braking System, Wheels	18
01 Tiller Unit(509946011007).....	18
02 Tiller(509946011010).....	20
03 Tiller(509946011011).....	22
04 Load Wheel (Tandem)(509946017001)	24
05 Caster (509946016501).....	26
06 Caster (509946016502).....	28
Chapter 5: Electrical Parts	30
01 Wire Harness (509946033008).....	30
02 Wire Harness (509946033013).....	32
03 Electronic components (509946033010).....	34
04 Electronic components (509946033014).....	36
05 Charger (509946036501)	38
06 Traction Battery (509946037004)	40
Chapter 6: Others	42
01 Labels and Decals-EU (509946047001)	42
02 Labels and Decals-US (509946047002).....	44
Appendix.....	46
01 Electrical Circuit Diagram (509946045506).....	46
02 Electrical Circuit Diagram (509946045507).....	47
03 Hydraulic Circuit Diagram (508046045502)	48
04 Consumable Parts List.....	49

Chapter 1: Drive System

01 Drive Unit Steering(20Q)(509946013502)

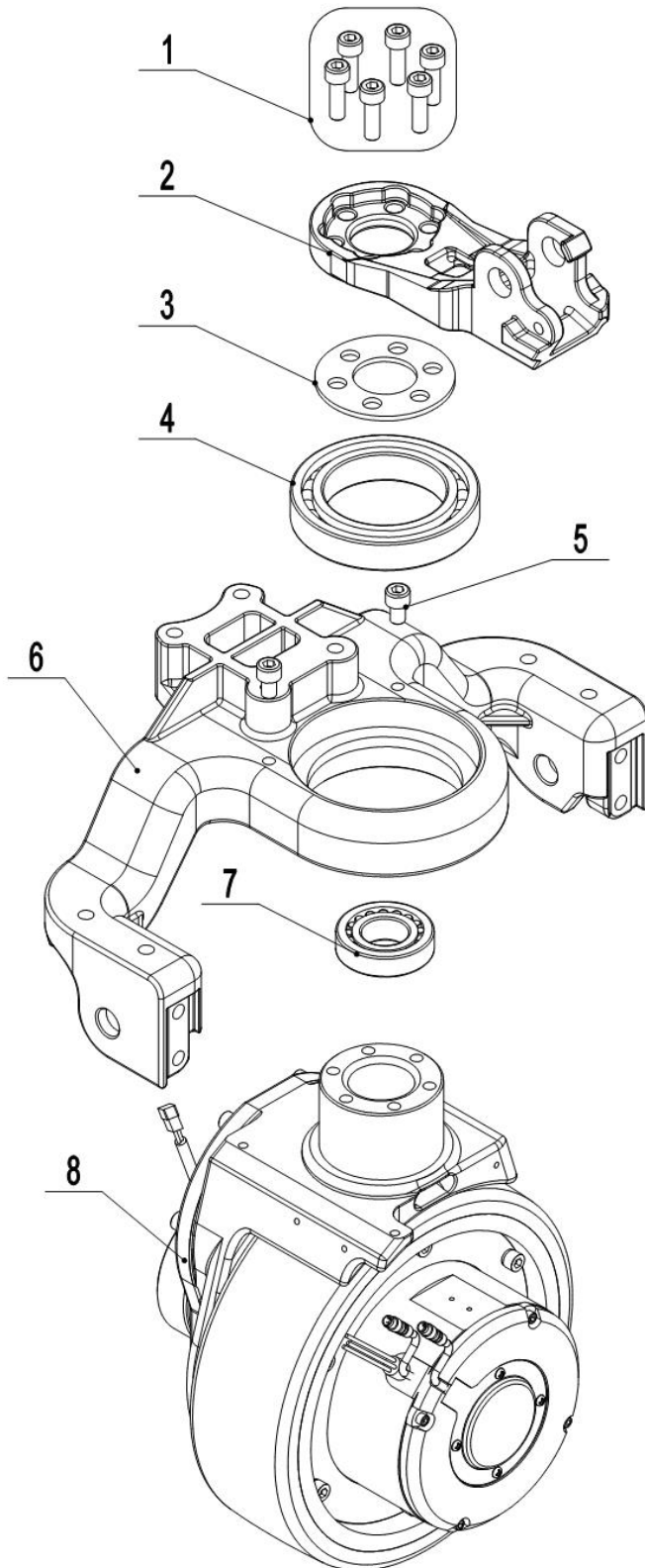

509946013502

1=整包供货

2=限制供货

3=逐渐停止供货

4=不单件供货

5=见另外表单

01 Drive Unit Steering(20Q)(509946013502)

No.	Item Code	Mark	Item Description	Qty.	Substitute	Note
1	910200200058	1	Screw	6		
2	509913520004		Flange	1		
3	509913520002		Subplate	1		
4	910700200058		Bearing	1		
5	910200200074	1	Screw	2		
6	509913520006		Wheel Mount	1		
7	910700600044		Bearing	1		
8	509998510100	2	Drive Unit	1		

02 Drive Assembly(20Q)(509946013003)

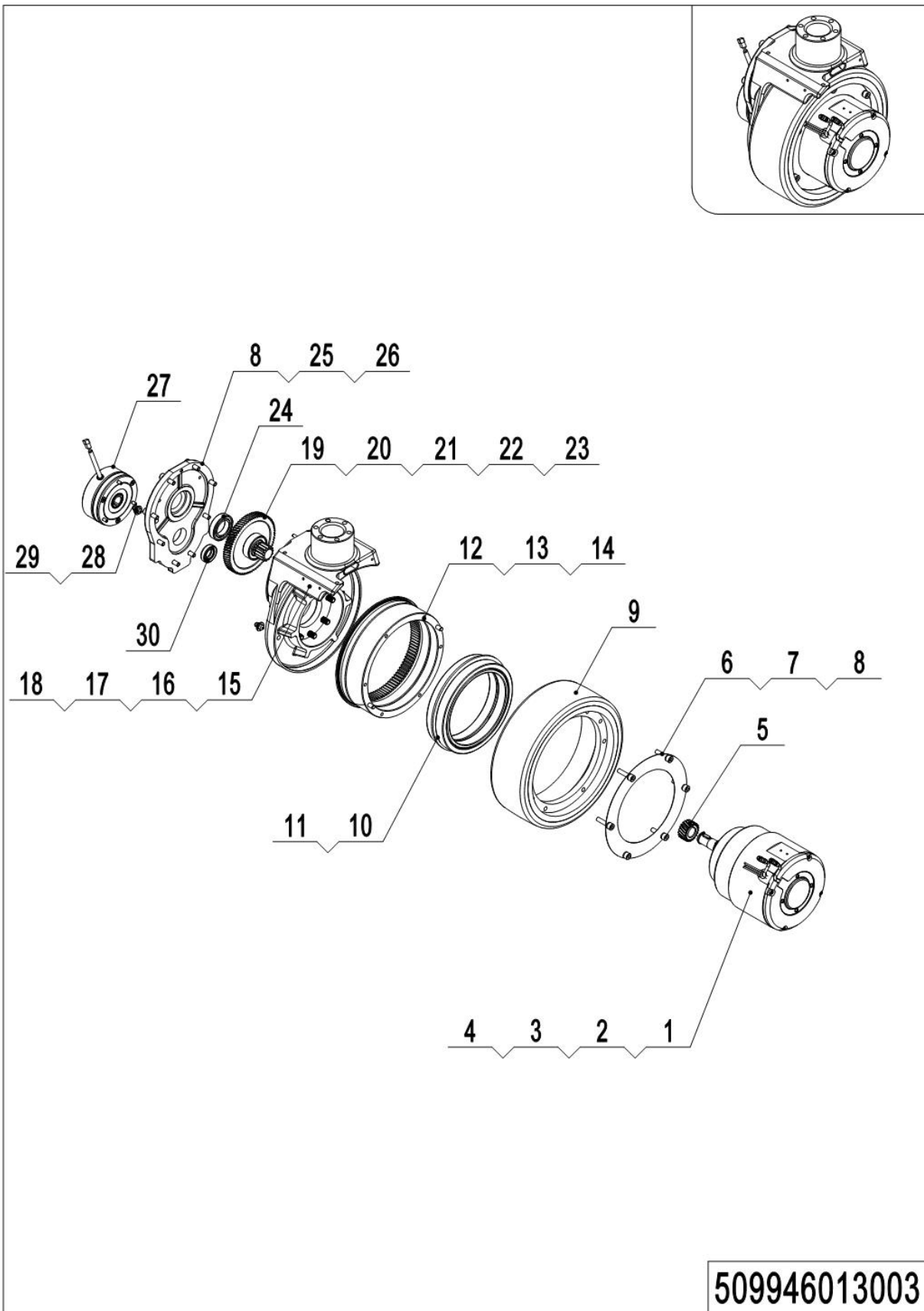

1=整包供货

2=限制供货

3=逐渐停止供货

4=不单件供货

5=见另外表单

02 Drive Assembly(20Q)(509946013003)

No.	Item Code	Mark	Item Description	Qty.	Substitute	Note
1	961001800001		Motor	1		
2	910600800005		Flat Key	2		
3	910401300006		Circlip	1		
4	910401300007		Circlip	1		
5	961000700006		Gear	1		
6	961001300009		Scraper Seal	1		
7	910200200140		Screw	6		
8	910400500018		Spring Washer	14		
9	961001300010		Wheel	1		
10	910700200044		Bearing	2		
11	910401400023		Circlip	1		
12	961001300008		Gear	1		
13	910600100013		Cylindrical Pin	2		
14	961001300007		Oil Seal	1		
15	961002200001		Gearbox	1		
16	910200200147		Screw	5		
17	910400500019		Spring Washer	5		
18	910600100003		Cylindrical Pin	1		
19	961001300002		Gear	1		
20	961001300005		Gear Shaft	1		
21	910600800006		Flat Key	1		
22	910700200057		Bearing	1		
23	910401300008		Circlip	1		
24	910700200046		Bearing	1		
25	961002200002		Cover	1		
26	910200200139		Screw	8		
27	961002200004		Brake	1		
28	911200100003		Oil Cup	2		
29	910800900010		Bonded Washer	2		
30	961000700012		Oil Seal	1		

1=整包供货

2=限制供货

3=逐渐停止供货

4=不单件供货

5=见另外表单

Chapter 2: Hydraulic System

01 Hydraulic Components(20Q)(509946023504)

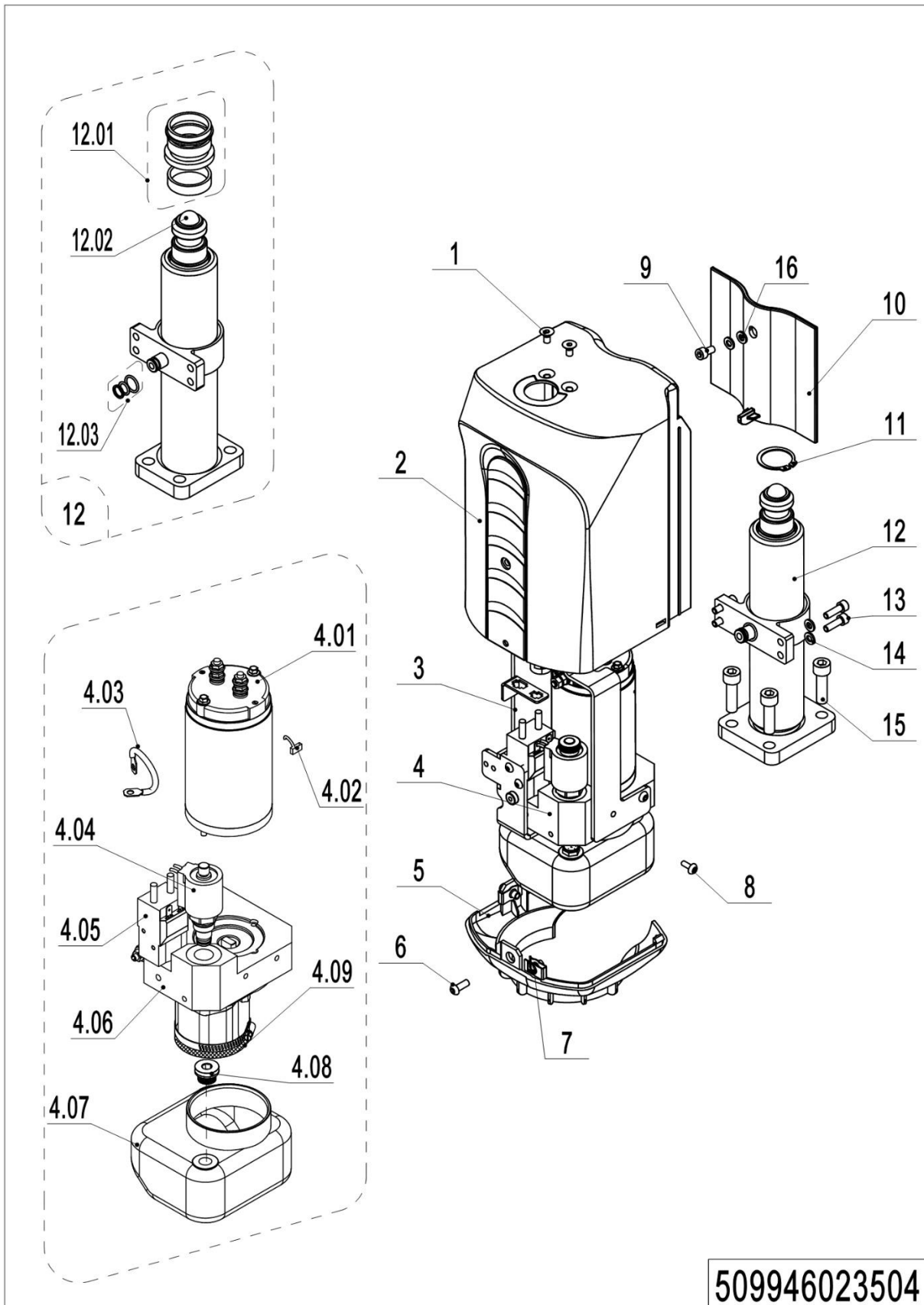

1=整包供货

2=限制供货

3=逐渐停止供货

4=不单件供货

5=见另外表单

01 Hydraulic Components(20Q)(509946023504)

No.	Item Code	Mark	Item Description	Qty.	Substitute	Note
1	910200400015	1	Screw	2		
2	509924020105		Cover	1		
3	509924010004		Mounting Rack	1		
4	950900100057	2	Pump Unit	1		
4.01	508598510007	2	Motor	1		
4.02	508598520014	2	Carbon Brush	1		
4.03	508598520001	2	Coil	1		YC048DC
4.04	505698520054	2	Magnetic Valve	1		SCV
4.05	508598520011		Switch	1		DK0148B
4.06	508598510008		Gear Pump	1		CBU-F1038
4.07	508598510010		Tank	1		0.4L-TP072A080-V
4.08	508598510009		Cap-Tank	1		Z3/8
4.09	508598520005	2	Filter	1		
5	509924020102	1	Shield	1		
6	910200300017	1	Screw	2		
7	940400400005	1	Cage Nut	2		
8	910200300018	1	Screw	3		
9	910200200176	1	Screw	1		black
10	509924020104		Cover	1		
11	910401300017		Circlip	1		
12	509924010001		Cylinder	1		
12.01	509924010005		Seal Kit	1		
12.02	910701100019		Steel Ball	1		
12.03	508598510004		Seal Kit	1		
13	910200200036	1	Screw	4		
14	910400100005	1	Flat Washer	4		
15	910200200075	1	Screw	4		
16	910400500005	1	Spring Washer	2		

1=整包供货

2=限制供货

3=逐渐停止供货

4=不单件供货

5=见另外表单

02 Hydraulic Components (EN1175-2020)(509946023511)

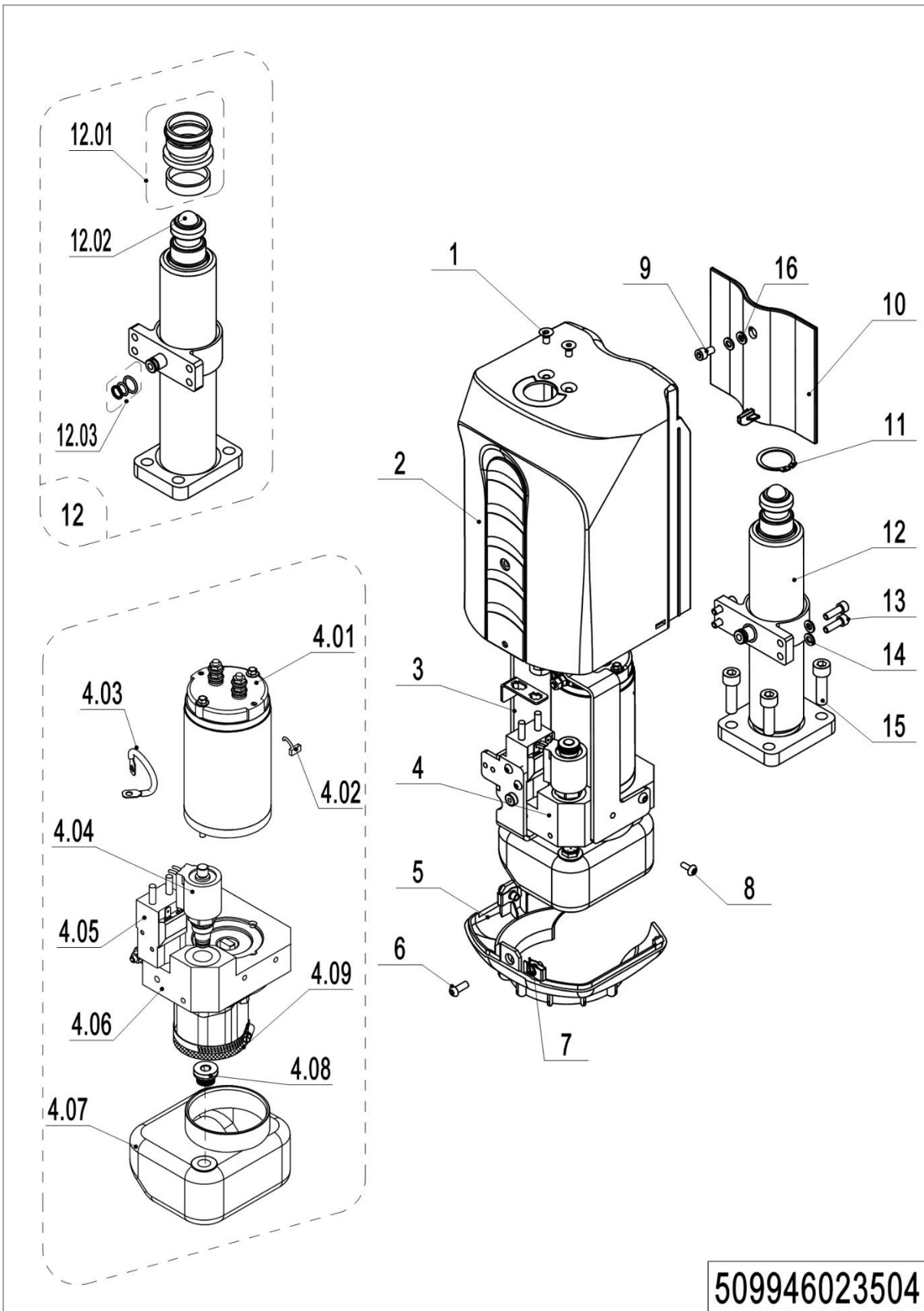

509946023504

1=整包供货

2=限制供货

3=逐渐停止供货

4=不单件供货

5=见另外表单

02 Hydraulic Components(EN1175-2020)(509946023511)

No.	Item Code	Mark	Item Description	Qty.	Substitute	Note
1	910200400015	1	Screw	2		
2	509924020105		Cover	1		
3	509924010006		Mounting Rack	1		
4	950900100057	2	Pump Unit	1		
4.01	508598510007	2	Motor	1		
4.02	508598520014	2	Carbon Brush	1		
4.03	508598520001	2	Coil	1		YC048DC
4.04	505698520054	2	Magnetic Valve	1		SCV
4.05	508598520011		Switch	1		DK0148B
4.06	508598510008		Gear Pump	1		CBU-F1038
4.07	508598510010		Tank	1		0.4L-TP072A080-V
4.08	508598510009		Cap-Tank	1		Z3/8
4.09	508598520005	2	Filter	1		
5	509924020102	1	Shield	1		
6	910200300017	1	Screw	2		
7	940400400005	1	Cage Nut	2		
8	910200300018	1	Screw	3		
9	910200200176	1	Screw	1		black
10	509924020104		Cover	1		
11	910401300017		Circlip	1		
12	509924010001		Cylinder	1		
12.01	509924010005		Seal Kit	1		
12.02	910701100019		Steel Ball	1		
12.03	508598510004		Seal Kit	1		
13	910200200036	1	Screw	4		
14	910400100005	1	Flat Washer	4		
15	910200200075	1	Screw	4		
16	910400500005	1	Spring Washer	2		

1=整包供货

2=限制供货

3=逐渐停止供货

4=不单件供货

5=见另外表单

Chapter 3: Truck Frame

01 Truck Frame (509946038501)

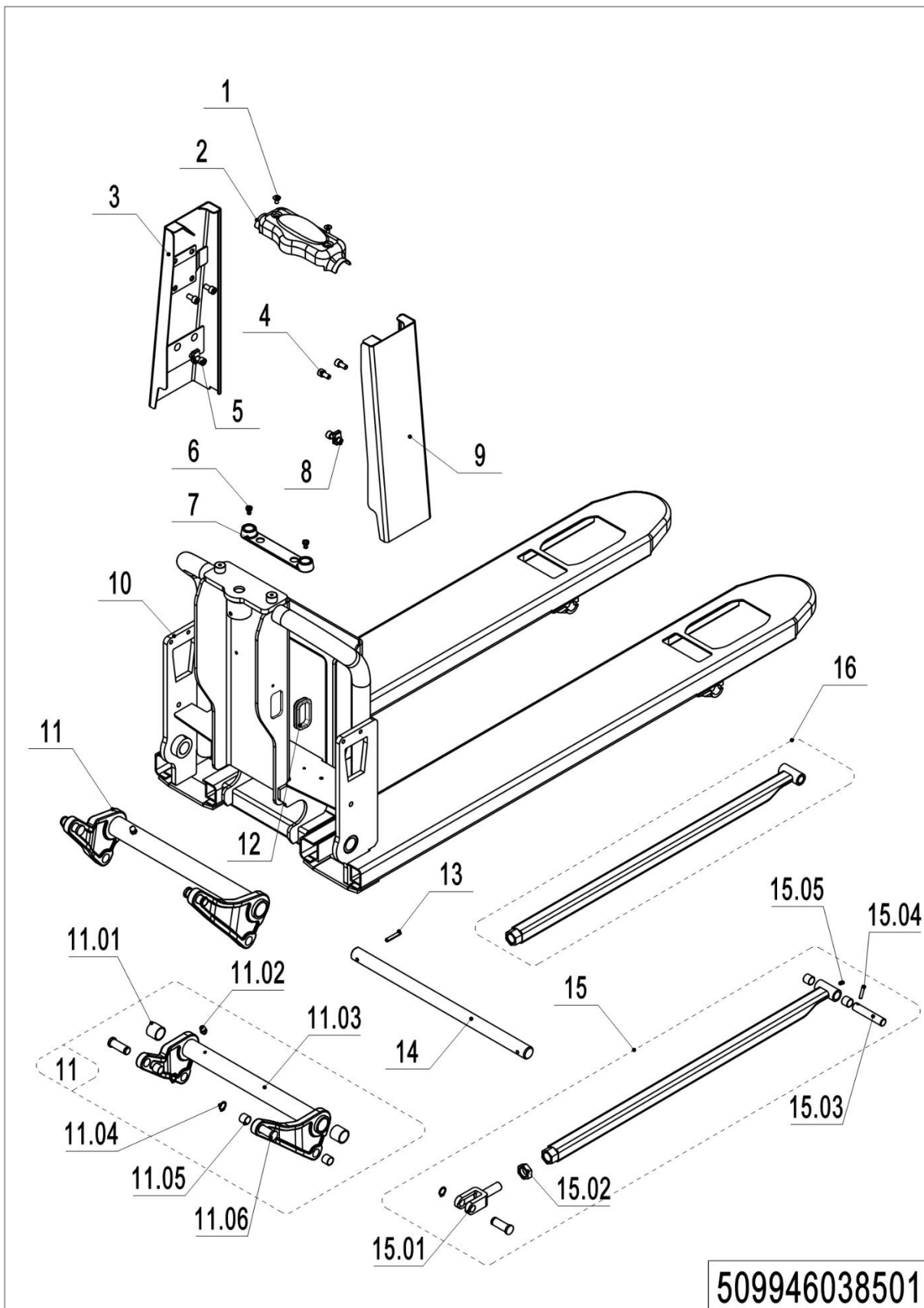

1=整包供货

2=限制供货

3=逐渐停止供货

4=不单件供货

5=见另外表单

01 Truck Frame (509946038501)

No.	Item Code	Mark	Item Description	Qty.	Substitute	Note
1	910200400015	1	Screw	2		
2	509938520100		Cover	1		
3	509938510011		Side Plate2	1		
4	910200200156	1	Screw	4		
5	910200200157	1	Screw	2		
6	910200500034	1	Screw	2		
7	509938520009		Battery Rack	1		
8	940400400002	1	Cage Nut	2		
9	509938510010		Side Plate1	1		
10	509938510020	2	Chassis (540x1150)	1		
10	509938510024	2	Chassis (540x1220)	1		
11	509998510029		Rise Arm	1		
11.01	940500100097		Bushing	2		
11.02	911200100002		Oil Cup	1		
11.03	509938510016		Rise Arm(540)	1		
11.04	910401300007		Circlip	4		
11.05	940500100083		Bushing	8		
11.06	502338520026		Pin	4		
12	509938520041		Jacket	1		
13	910600400041		Spring Pin	1		
14	508038520027		Axle	1		
15	509998510030		Push Rod Kit (1150)	2		
15	509998510031		Push Rod Kit (1220)	2		
15.01	502338520027		Push Rod Fork	2		
15.02	910300400008	1	Nut	2		
15.03	502338520030		Axle	2		
15.04	910600500002		Spring Pin	2		
15.05	911200100001		Oil Cup	1		
16	509938510002		Push Rod (1150)	2		
16	509938510003		Push Rod (1220)	2		

1=整包供货

2=限制供货

3=逐渐停止供货

4=不单件供货

5=见另外表单

02 Truck Frame (509946038502)

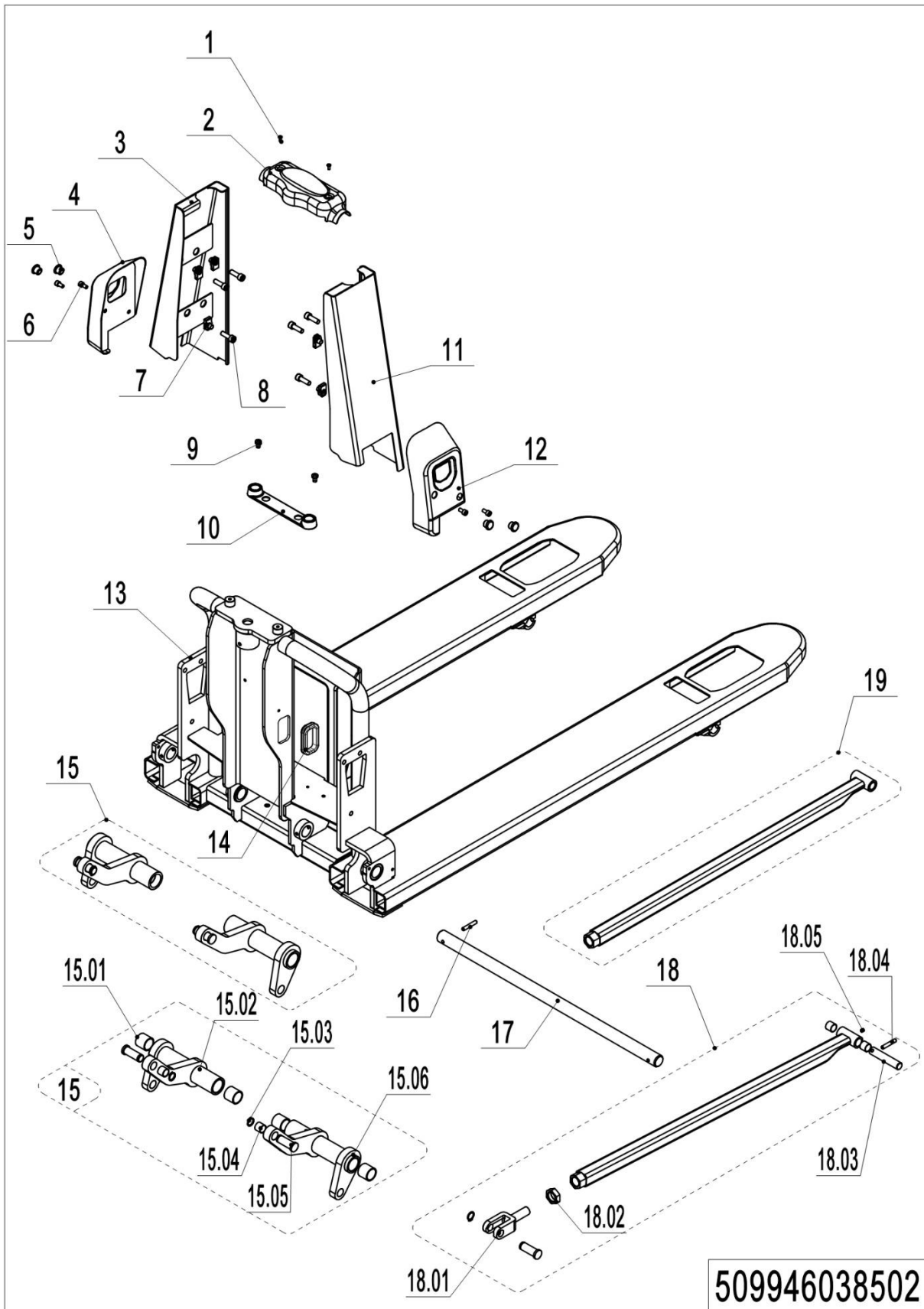

1=整包供货

2=限制供货

3=逐渐停止供货

4=不单件供货

5=见另外表单

02 Truck Frame (509946038502)

No.	Item Code	Mark	Item Description	Qty.	Substitute	Note
1	910200400015	1	Screw	2		
2	509938520100		Cover	1		
3	509938510013		Side Plate2	1		
4	509938510104		Side Cover (left 685)	1		
5	509938520103		Rubber Cover	4		
6	910200200033	1	Screw	4		
7	940400400002	1	Cage Nut	6		
8	910200200157	1	Screw	6		
9	910200500034	1	Screw	2		
10	509938520009		Battery Rack	1		
11	509938510012		Side Plate1	1		
12	509938510105		Side Cover (right 685)	1		
13	509938510021	2	Chassis (685x1150)	1		
13	509938510025	2	Chassis (685x1220)	1		
14	509938520041		Jacket	1		
15	509998510000		Rise Arm	1		
15.01	940500100097		Bushing	2		
15.02	509938510014		Rise Arm	1		
15.03	910401300007		Circlip	4		
15.04	940500100083		Bushing	8		
15.05	502338520026		Pin	4		
15.06	509938510015		Rise Arm	1		
16	910600400041		Spring Pin	1		
17	509938520033		Axle	1		
18	509998510030		Push Rod Kit (1150)	2		
18	509998510031		Push Rod Kit (1220)	2		
18.01	502338520027		Push Rod Fork	2		
18.02	910300400008	1	Nut	2		
18.03	502338520030		Axle	2		
18.04	910600500002		Spring Pin	2		
18.05	911200100001		Oil Cup	2		

1=整包供货

2=限制供货

3=逐渐停止供货

4=不单件供货

5=见另外表单

02 Truck Frame (509946038502) Continuation

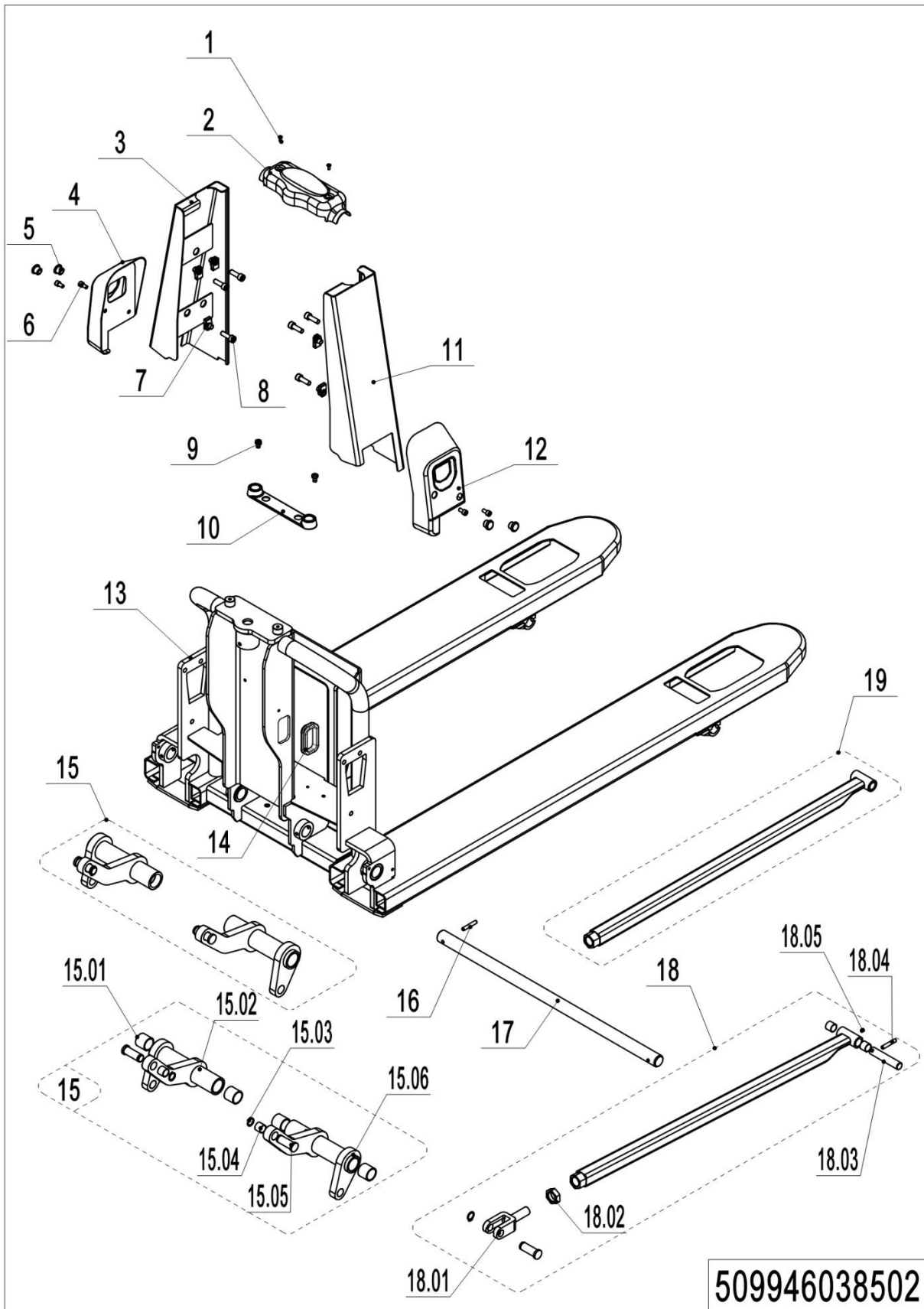

1=整包供货

2=限制供货

3=逐渐停止供货

4=不单件供货

5=见另外表单

02 Truck Frame (509946038502) Continuation

No.	Item Code	Mark	Item Description	Qty.	Substitute	Note
19	509938510002		Push Rod (1150)	1		
19	509938510003		Push Rod (1220)	1		

Chapter 4: Steering System, Braking System, Wheels

01 Tiller Unit(509946011007)

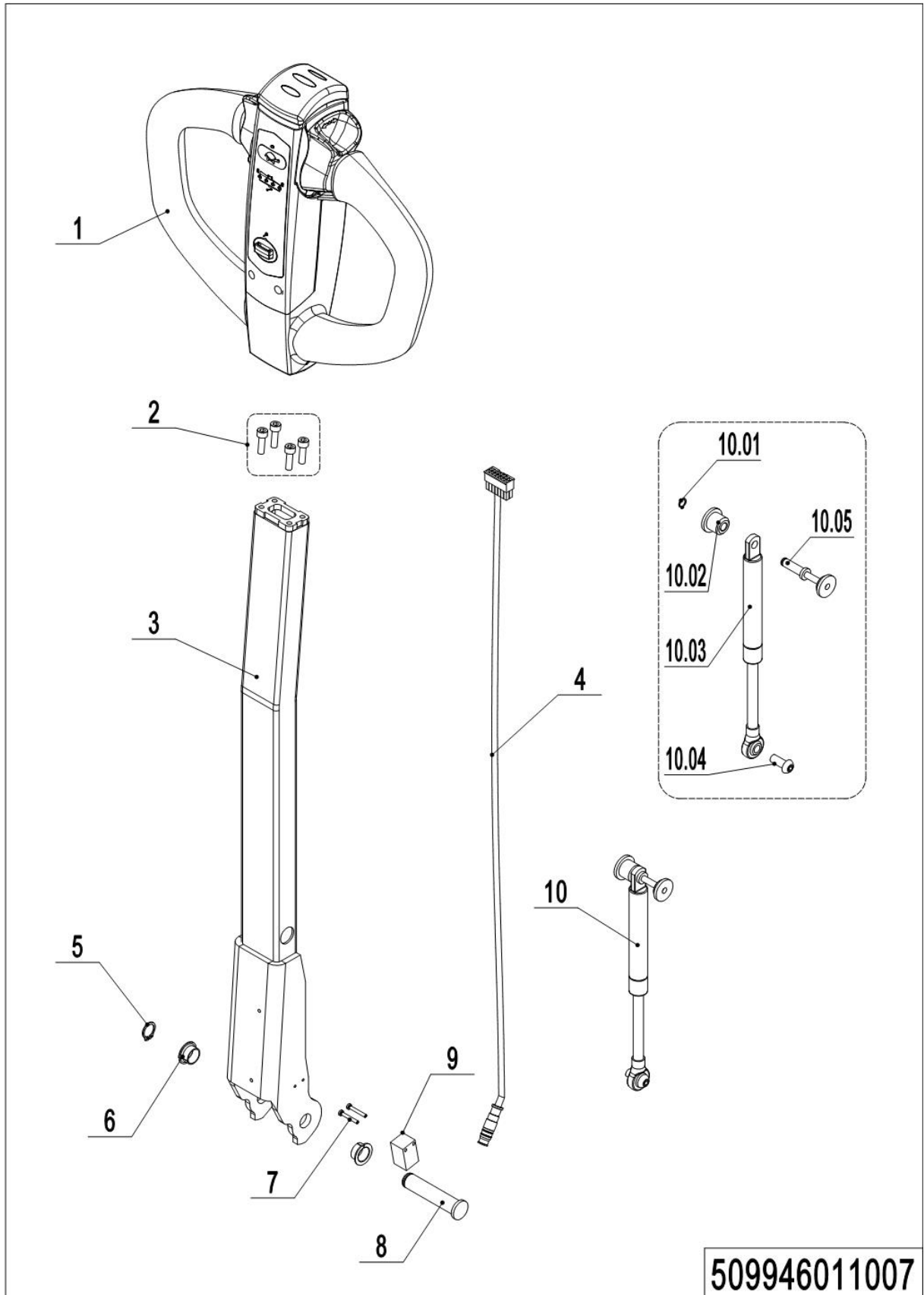

1=整包供货

2=限制供货

3=逐渐停止供货

4=不单件供货

5=见另外表单

01 Tiller Unit(509946011007)

No.	Item Code	Mark	Item Description	Qty.	Substitute	Note
1	922100100081	2	Control Handle	1		NL20 (26C-6. 1)
1	922100100125		Control Handle	1		EN1175
2	910200200036	1	Screw	4		
3	509911010002		Tiller	1		
4	509933010007		Wire Harness	1		
4	509933010049		Wire Harness	1		EN1175
5	910401300006		Circlip	1		
6	940500200001		Bushing	2		
7	941101100001	1	Screw	2		
8	508011020004		Pin	1		
9	920200400027		Proximity Switch	1		
10	508098510084		Gas Spring Kit	1		
10.1	910401300001		Circlip	1		
10.2	508011020005		Fixing Base	1		
10.3	508011010001		Gas Spring	1		
10.4	941100100011	1	Screw	1		
10.5	508011010002		Pin	1		

02 Tiller(509946011010)

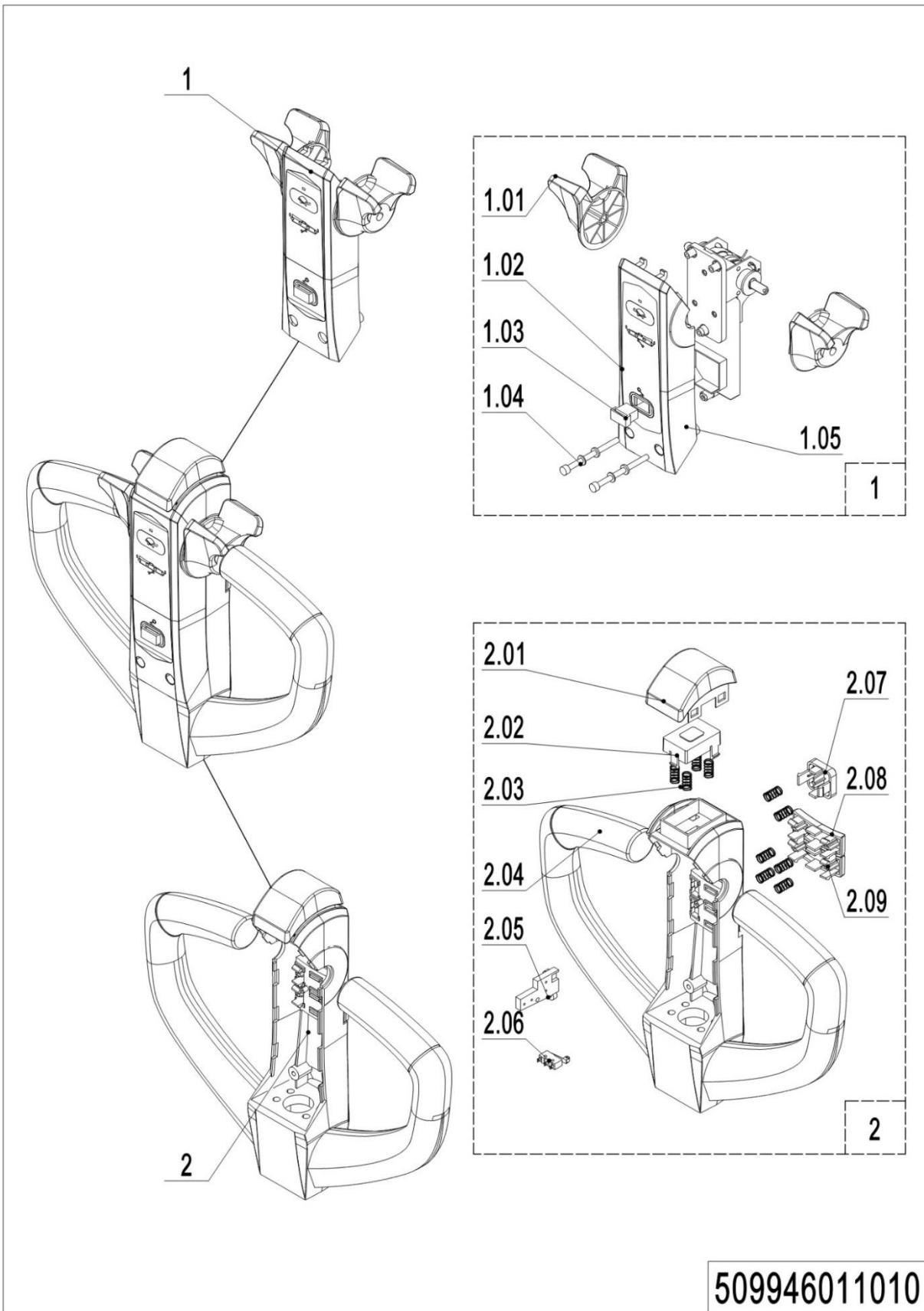

1=整包供货

2=限制供货

3=逐渐停止供货

4=不单件供货

5=见另外表单

02 Tiller(509946011010)

No.	Item Code	Mark	Item Description	Qty.	Substitute	Note
1	509998510036	2	Handle Cap	1		
1.01	509998520059		Traction lever Kits	1		
1.02	509998520061		Cap-control handle	1		
1.03	509998520024		magnetic?snap	1		
1.04	910200200030	1	Screw	2		M5*50
1.05	509998520025	2	Cover	1		
2	509998510016		Handle Cap	1		
2.01	509998520027		Button Cap	1		
2.02	509998520028		Cover	1		
2.03	509998520029		Spring	1		Ø 0.6* Ø 8.7*16
2.04	509998520030	2	Control Handle body	1		
2.05	509998520031		Wire Harness	1		
2.06	509998520032		Wire Harness	1		
2.07	509998520033		Button Cap	1		
2.08	509998520034		Button Cap	1		
2.09	509998520035		Button Cap	1		

03 Tiller(509946011011)

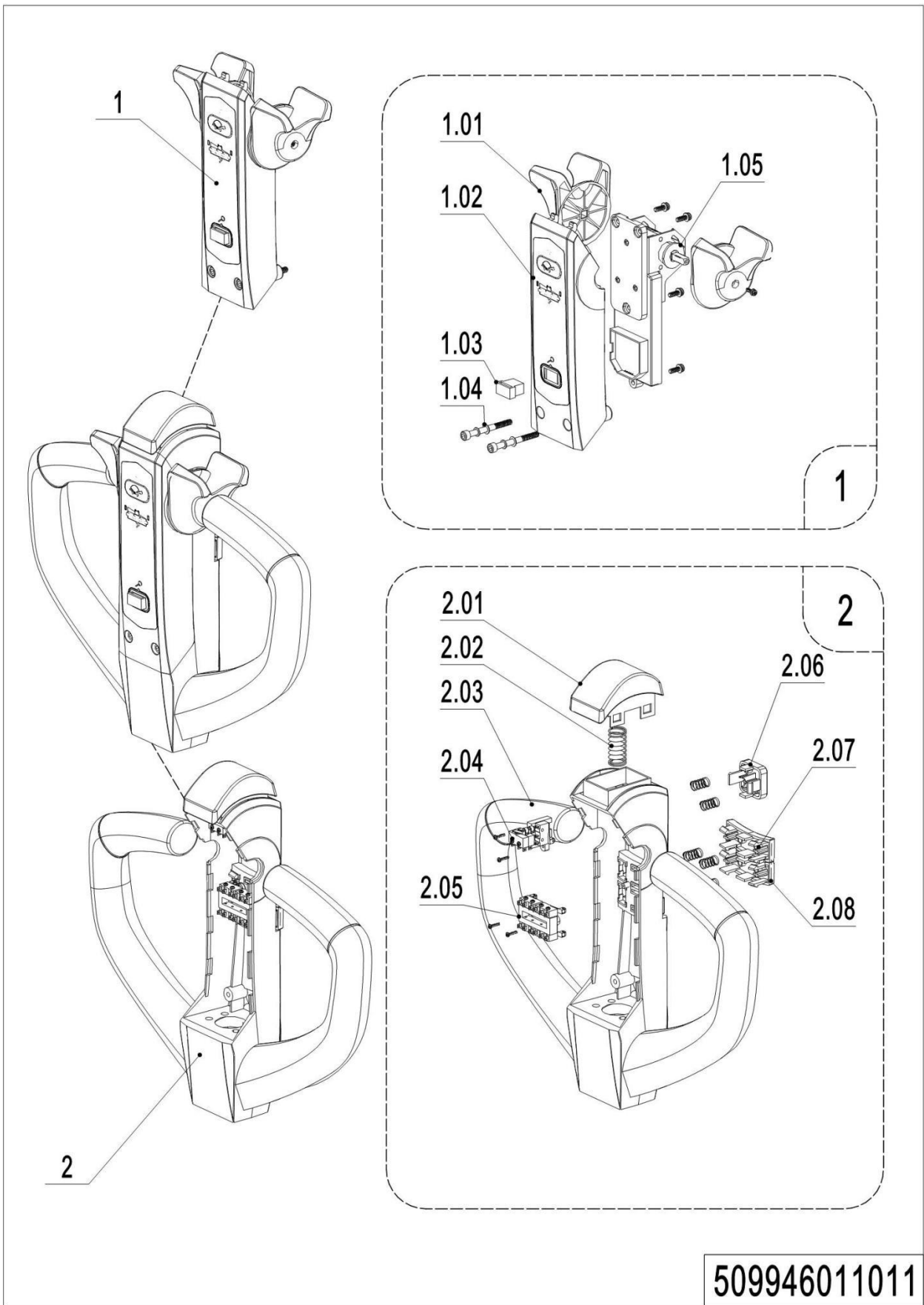

03 Tiller(5099460110011)

No.	Item Code	Mark	Item Description	Qty.	Substitute	Note
1	509998510044		Handle Cap	1		
1.01	509998520059		Traction lever Kits	2		
1.02	509998510045		Handle Cap	1		
1.03	509998520024		Magnetic snap	1		
1.04	910200200030		Screw	2		
1.05	509998510046		Accelerator	1		
2	509998510047		Handle Cap	1		
2.01	509998520027		Button Cap	1		
2.02	509998520029		Spring	1		
2.03	509998520030		Control Handle body	1		
2.04	509998520099		Wire Harness	1		
2.05	509998520032		Wire Harness	1		
2.06	509998520033		Button Cap	1		
2.07	509998520034		Button Cap	1		
2.08	509998520035		Button Cap	1		

04 Load Wheel (Tandem)(509946017001)

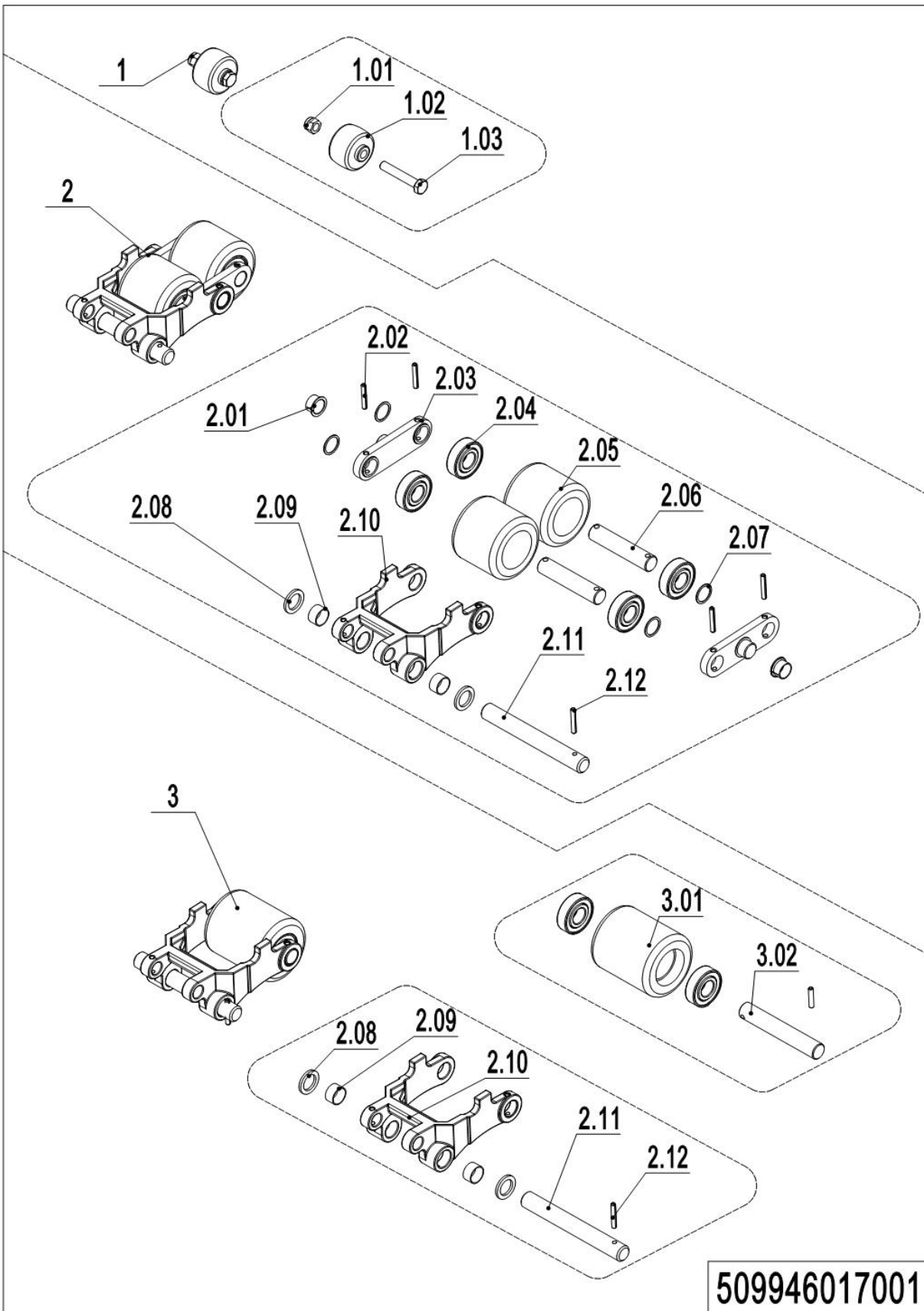

1=整包供货

2=限制供货

3=逐渐停止供货

4=不单件供货

5=见另外表单

04 Load Wheel (Tandem) (509946017001)

No.	Item Code	Mark	Item Description	Qty.	Substitute	Note
1	502398510003		Pulley components	2		
1.01	910300500005	1	Nut	2		
1.02	505638520039		Running Pulley	2		
1.03	941100200019	1	Bolt	2		
2	509998510004		Wheel	2		
2.01	940500200038		Bushing	4		
2.02	910600500004	1	Spring Pin	8		
2.03	508017020001		Plate	4		
2.04	910700200019		Bearing	8/4		
2.05	940300300047		WheelΦ80x70	4		
2.06	502317020001		Axle	4		
2.07	940600500013		Washer	8/4		double /Single
2.08	502338520033		Roller	4		
2.09	940500100088		Bushing	4		
2.10	508038520110		Riser	2		
2.11	502338520031		Pin	2		
2.12	910600400025		Spring Pin	2		
3	509998510005	2	Wheel	2		
3.01	940300300023		Wheel Φ80x93	2		
3.02	301017020001		Axle	2		

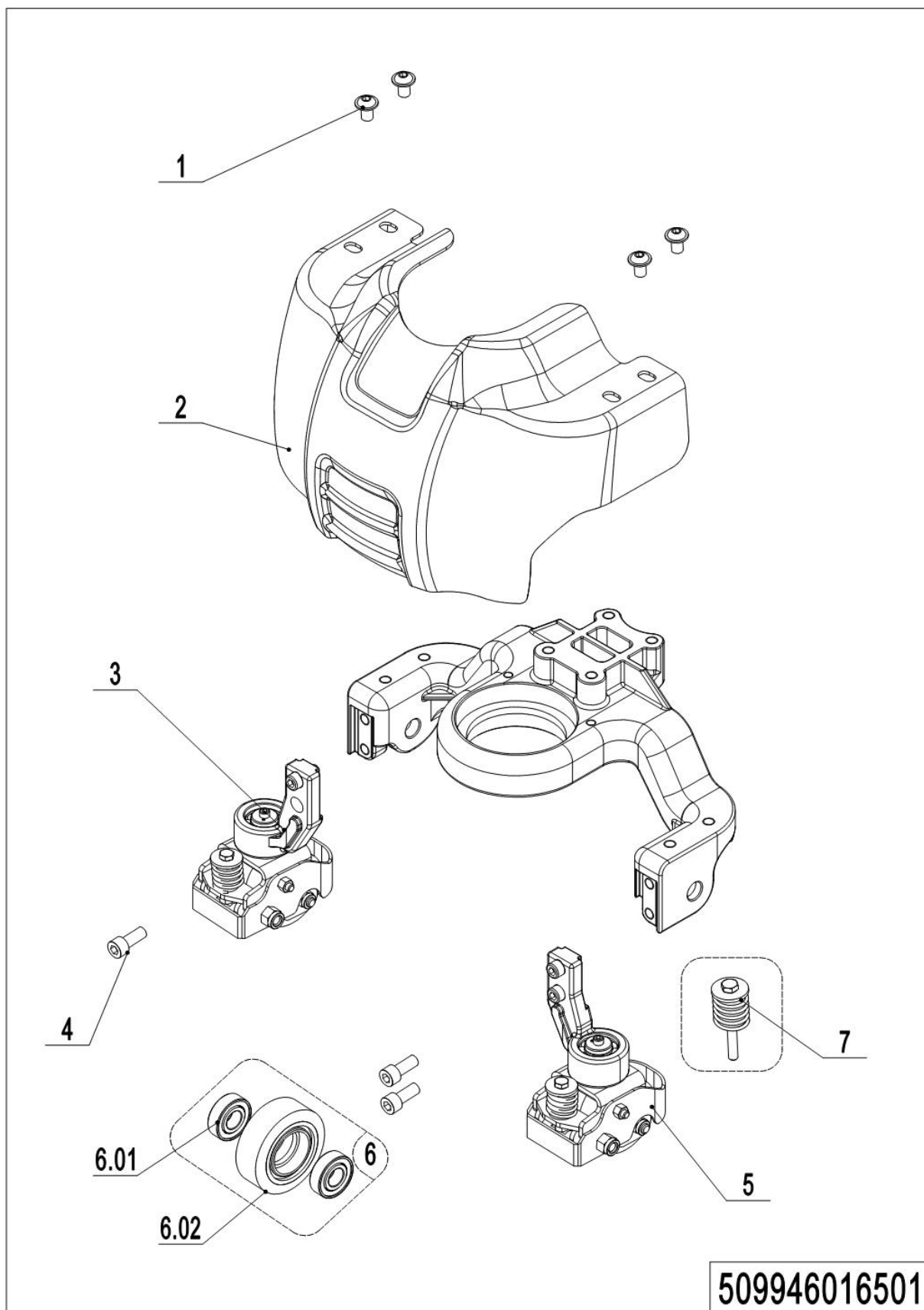
05 Caster (509946016501)

1=整包供货

2=限制供货

3=逐渐停止供货

4=不单件供货

5=见另外表单

05 Caster (509946016501)

No.	Item Code	Mark	Item Description	Qty.	Substitute	Note
1	941100100005	1	Screw	4		
2	509916520001		Apron	1		
3	508016510002		Caster Assembly	1		
4	910200200076	1	Screw	4		
5	508016510005		Caster Assembly	1		
6	502398510015	2	Load Wheel Kit	2		
6.01	910700200018		Bearing	4		
6.02	940300300017		Wheel Φ 80x30	2		
7	508098510047		Spring Components	2		

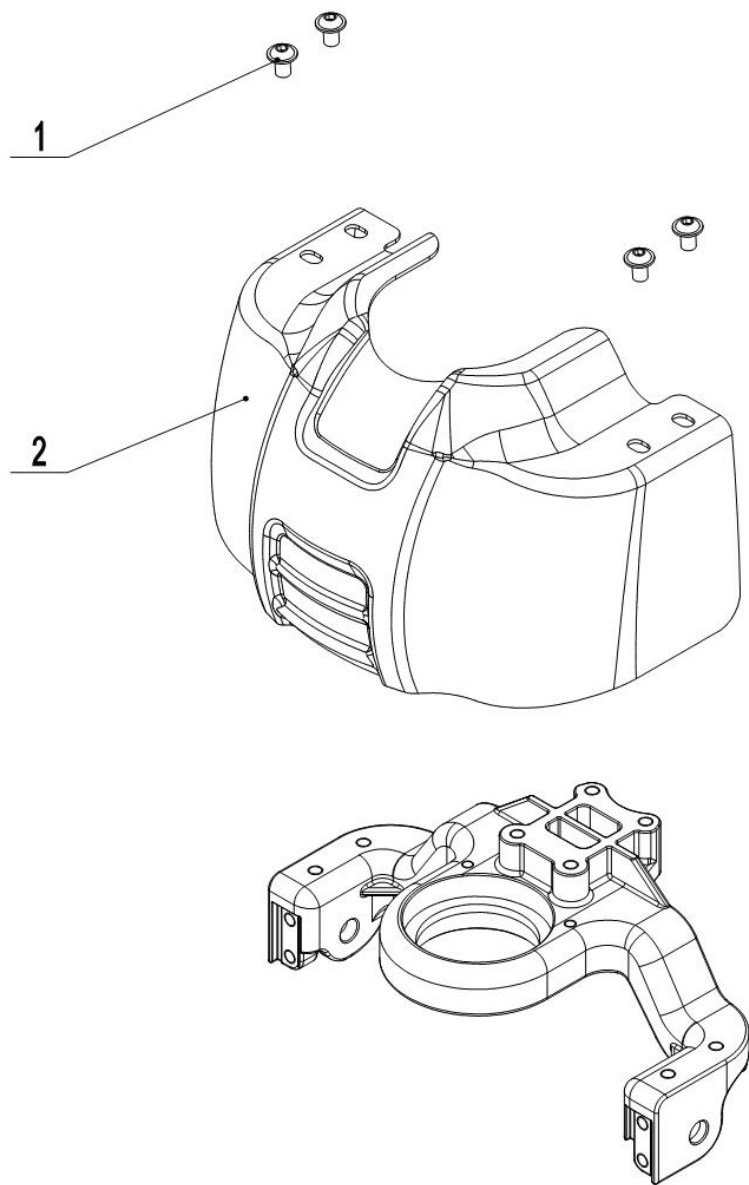
06 Caster (509946016502)**509946016502**

06 Caster (509946016502)

No.	Item Code	Mark	Item Description	Qty.	Substitute	Note
1	941100100005	1	Screw	4		
2	509916520000		Apron	1		

Chapter 5: Electrical Parts

01 Wire Harness (509946033008)

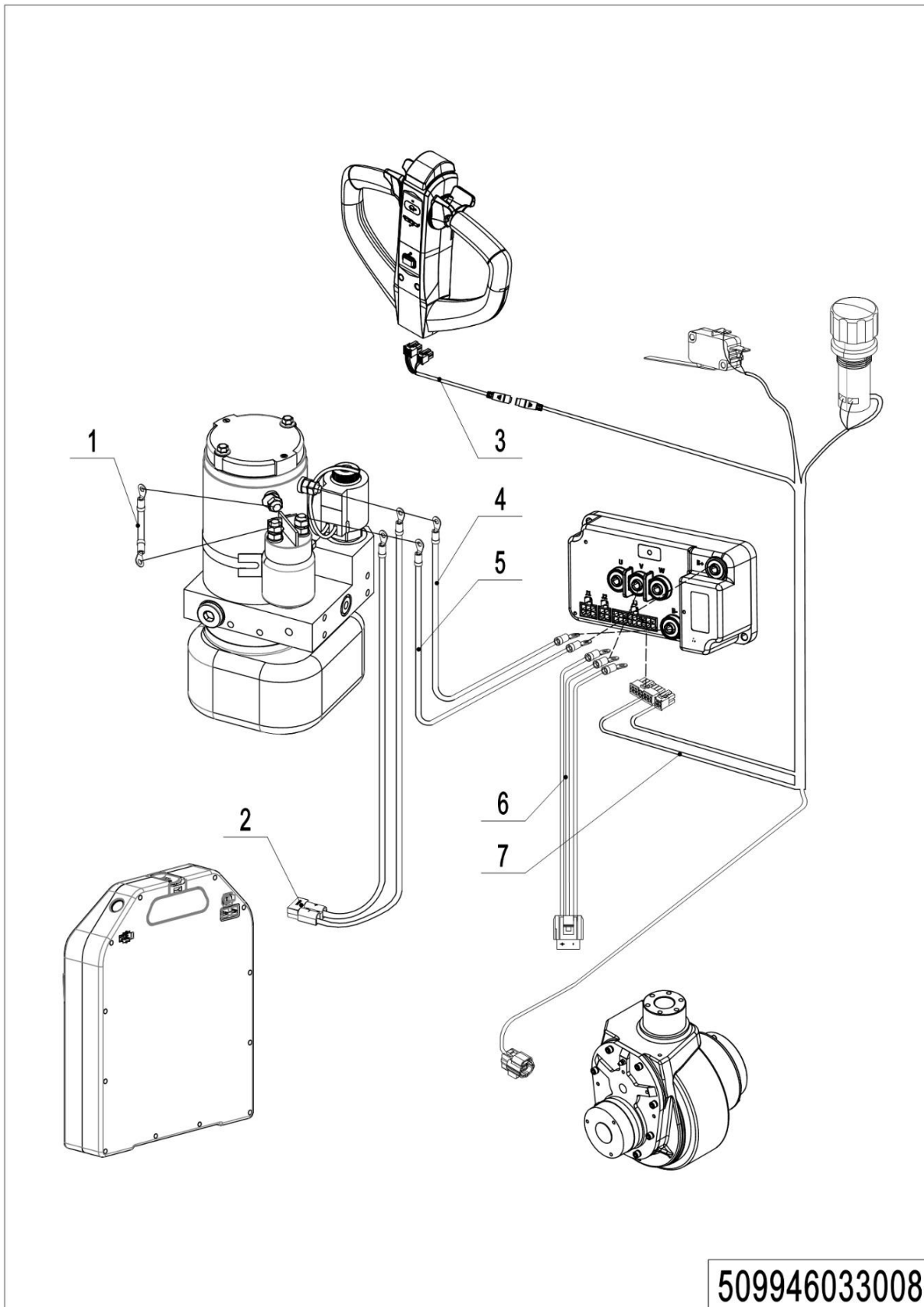

1=整包供货

2=限制供货

3=逐渐停止供货

4=不单件供货

5=见另外表单

01 Wire Harness (509946033008)

No.	Item Code	Mark	Item Description	Qty.	Substitute	Note
1	509933010012		Cables	1		
2	509933010017		Wire Harness	1		
3	509933010038		Wiring Harness	1		
4	509933010014		Cables	1		
5	509933010013		Cables	1		
6	509933010018		Wiring Harness	1		
7	509933010030		Wire Harness	1		

02 Wire Harness (509946033013)

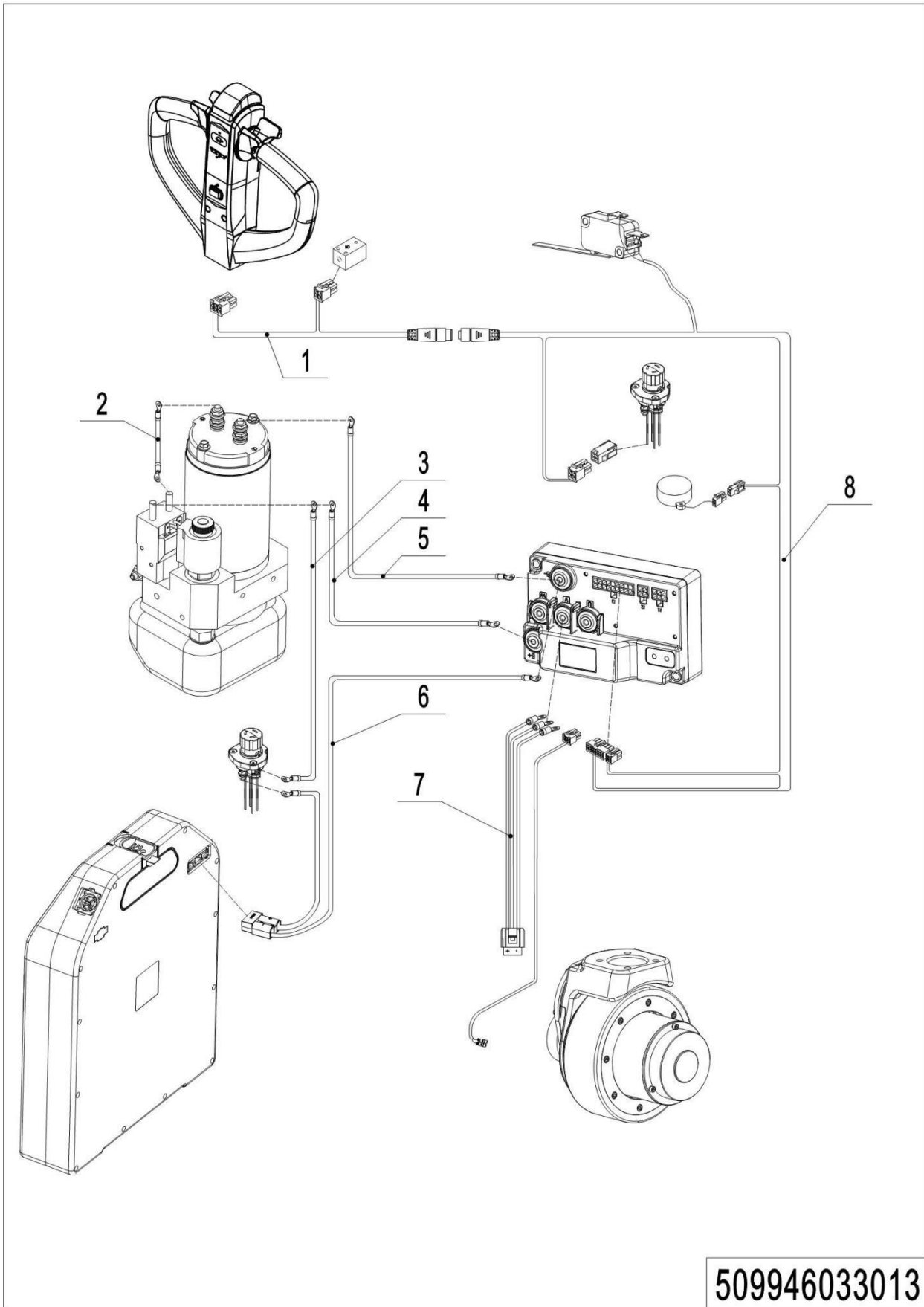

1=整包供货

2=限制供货

3=逐渐停止供货

4=不单件供货

5=见另外表单

02 Wire Harness (509946033013)

No.	Item Code	Mark	Item Description	Qty	Substitute	Note
1	509933010049		Wire Harness	1		
2	509933010012		Cables	1		
3	508033010033		Wire Harness	1		
4	508533010004		Wire Harness	1		
5	508533010005		Wire Harness	1		
6	509933010050		Wire Harness	1		
7	508533010007		Wire Harness	1		
8	509933010048		Wiring Harness	1		

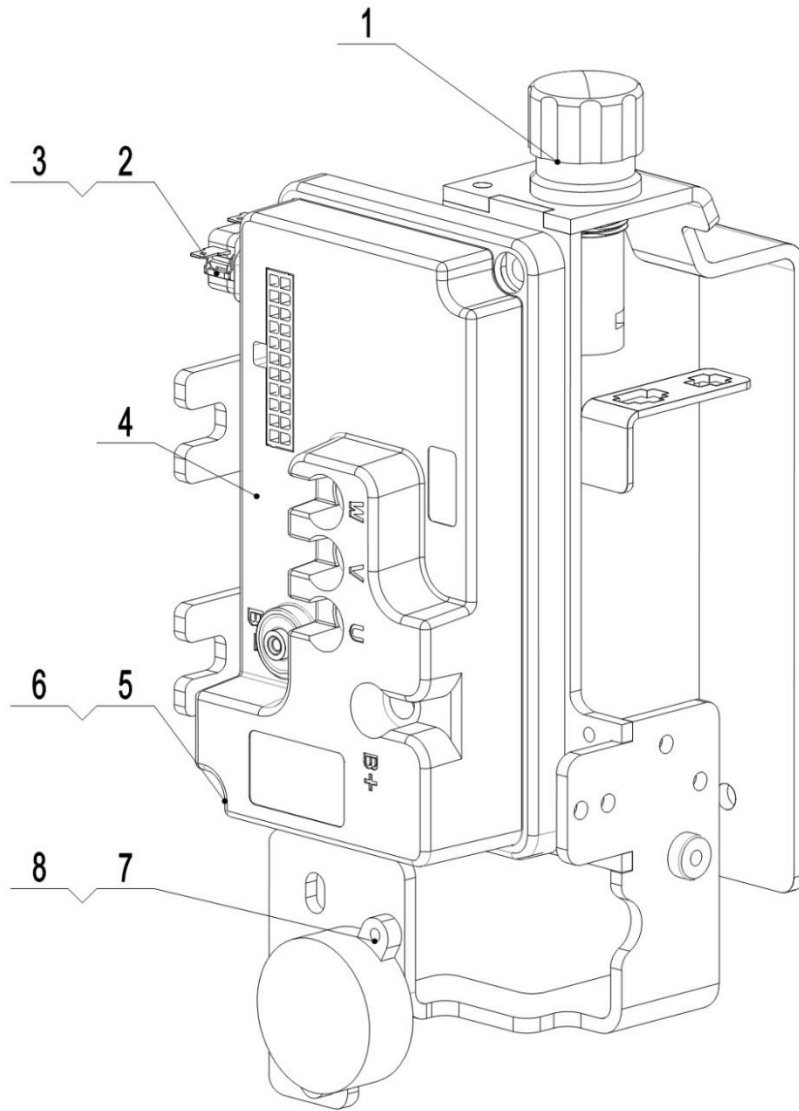
03 Electronic components (509946033010)

509946033010

1=整包供货

2=限制供货

3=逐渐停止供货

4=不单件供货

5=见另外表单

03 Controller (509946033010)

No.	Item Code	Mark	Item Description	Qty.	Substitute	Note
1	920200100028		Emergency Button	1		
2	920200300012		Microswitch	1		
3	910200200004	1	Screw	2		
4	921400100130		Controller	1		
5	910200200023	1	Screw	2		
6	910400500017	1	Spring Washer	2		
7	910200200004		Screw	1		
8	910200300002	1	Screw	2		

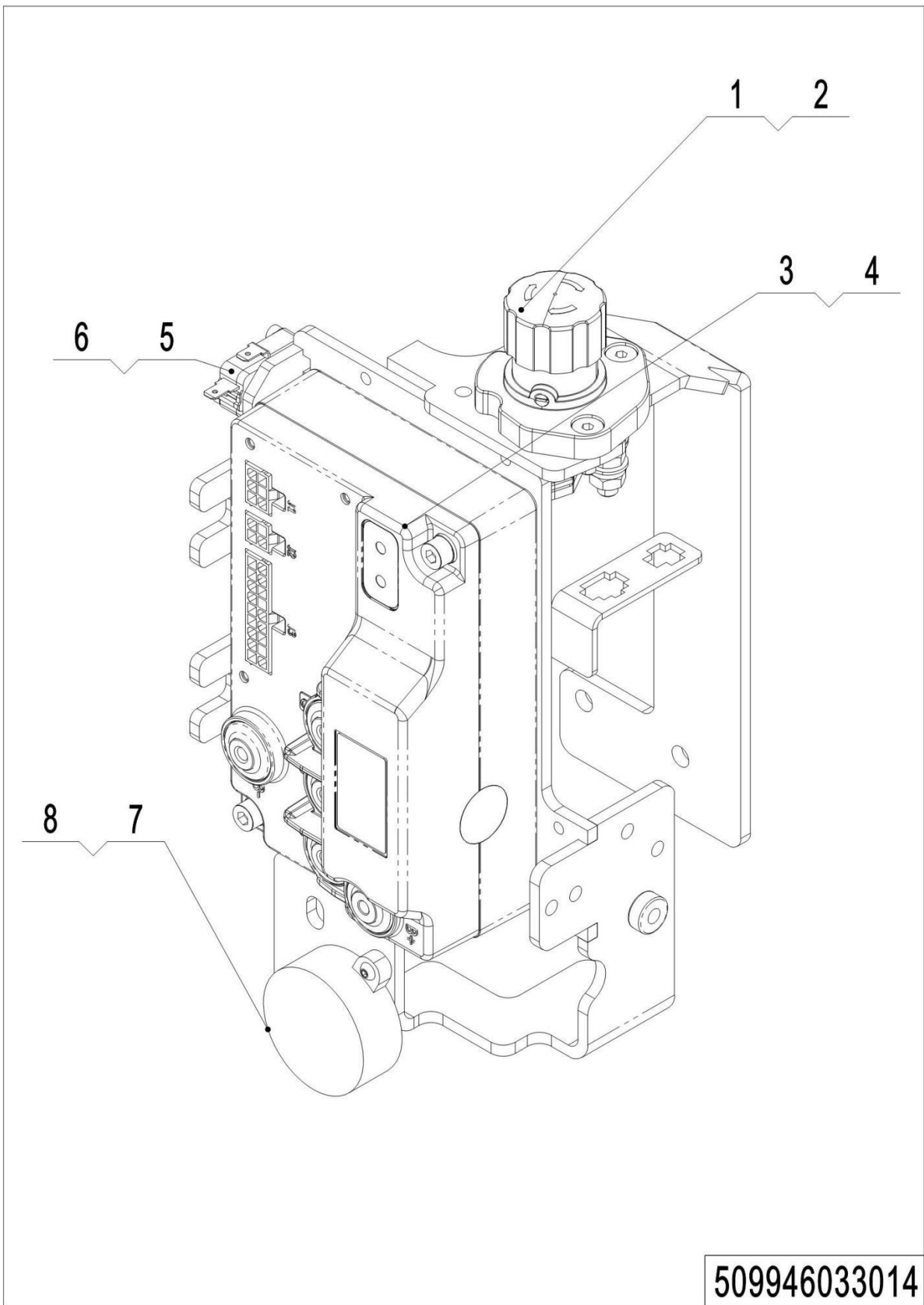
04 Electronic components (509946033014)

1=整包供货

2=限制供货

3=逐渐停止供货

4=不单件供货

5=见另外表单

04 Electronic components (509946033014)

No.	Item Code	Mark	Item Description	Qty.	Substitute	Note
1	920200100027		Emergency Button	1		
2	910200400010		Screw	2		
3	910200200027		Screw	2		
4	921400100093		Controller	1		
5	920200300012		Microswitch	1		
6	910200200004		Screw	2		
7	509998520063		Buzzer	1		
8	910200300002		Screw	2		

05 Charger (509946036501)

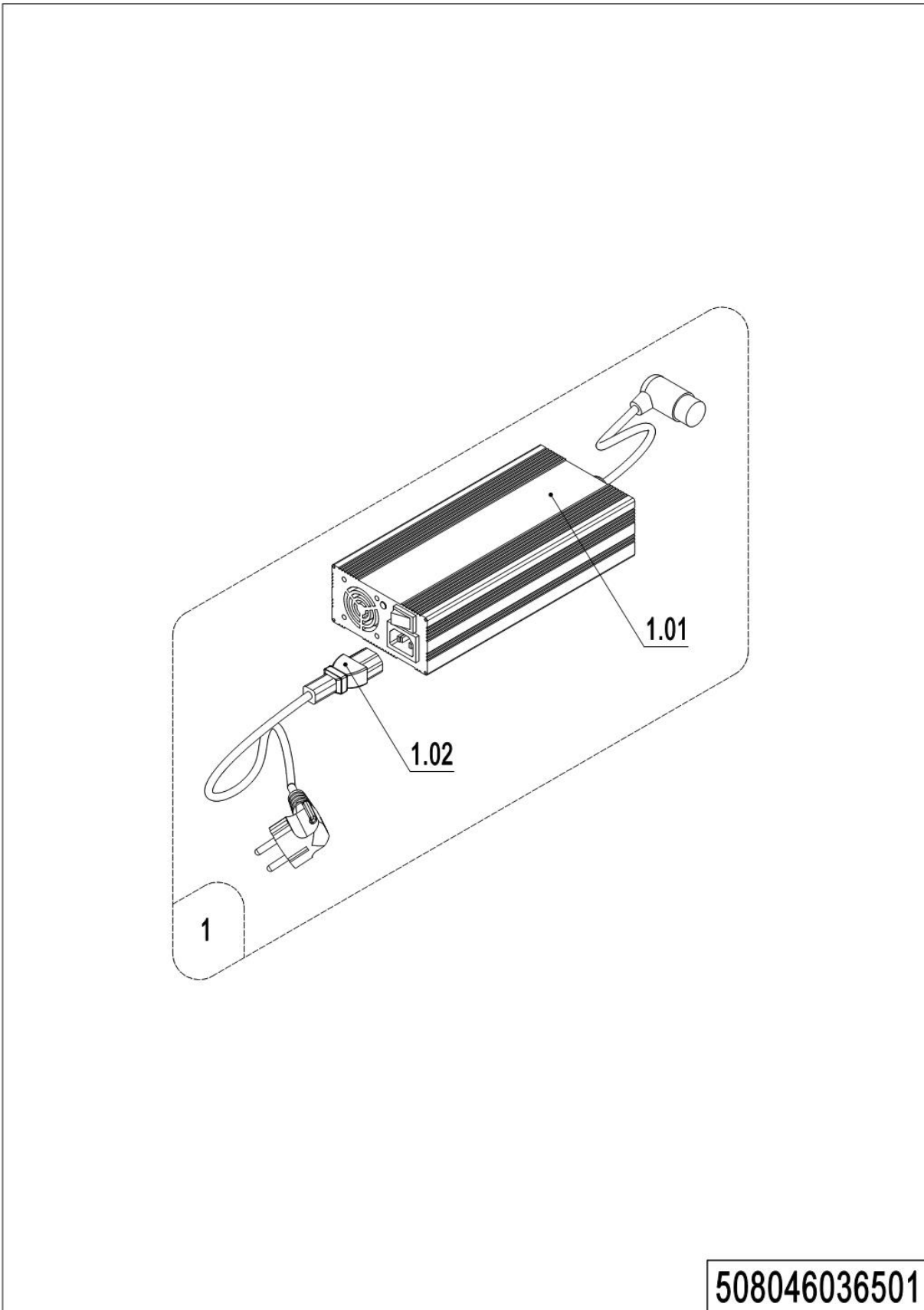

05 Charger (509946036501)

No.	Item Code	Mark	Item Description	Qty.	Substitute	Note
1	508536510013		Charger48V9A (Asia)	1		
1	508536510014		Charger48V9A (ENG)	1		
1	508536510015		Charger48V9A (US)	1		
1	508536510016		Charger48V9A (EU)	1		
1	508536510017		Charger48V9A (AUS)	1		
1	508536510018		Charger48V9A (ITA)	1		
1	508536510019		Charger48V9A (CH)	1		
1	508536510020		Charger48V9A (ISR)	1		
1	508536510021		Charger48V9A (BRA)	1		
1	508536510022		Charger48V9A (ARG)	1		
1	508536510023		Charger48V9A (ZA)	1		South Africa
1	508536510024		Charger48V9A (KR)	1		
1.01	921000200591		Charger48V9A (Asia)	1		
1.01	921000200581		Charger48V9A (EU)	1		
1.01	921000200585		Charger48V9A (US)	1		
1.02	921500200050		Power Cord (ARG)	1		
1.02	921500200024		Power Cord (AUS)	1		
1.02	921500200049		Power Cord (BRA)	1		
1.02	921500200023		Power Cord (USA)	1		
1.02	921500200022		Power Cord (EU)	1		
1.02	921500200026		Power Cord (CH)	1		
1.02	921500200028		Power Cord (ISR)	1		
1.02	921500200025		Power Cord (ITA)	1		
1.02	921500200021		Power Cord (Asia)	1		
1.02	921500200027		Power Cord (ENG)	1		
1.02	921500200063		Power Cord (ZA)	1		

1=整包供货

2=限制供货

3=逐渐停止供货

4=不单件供货

5=见另外表单

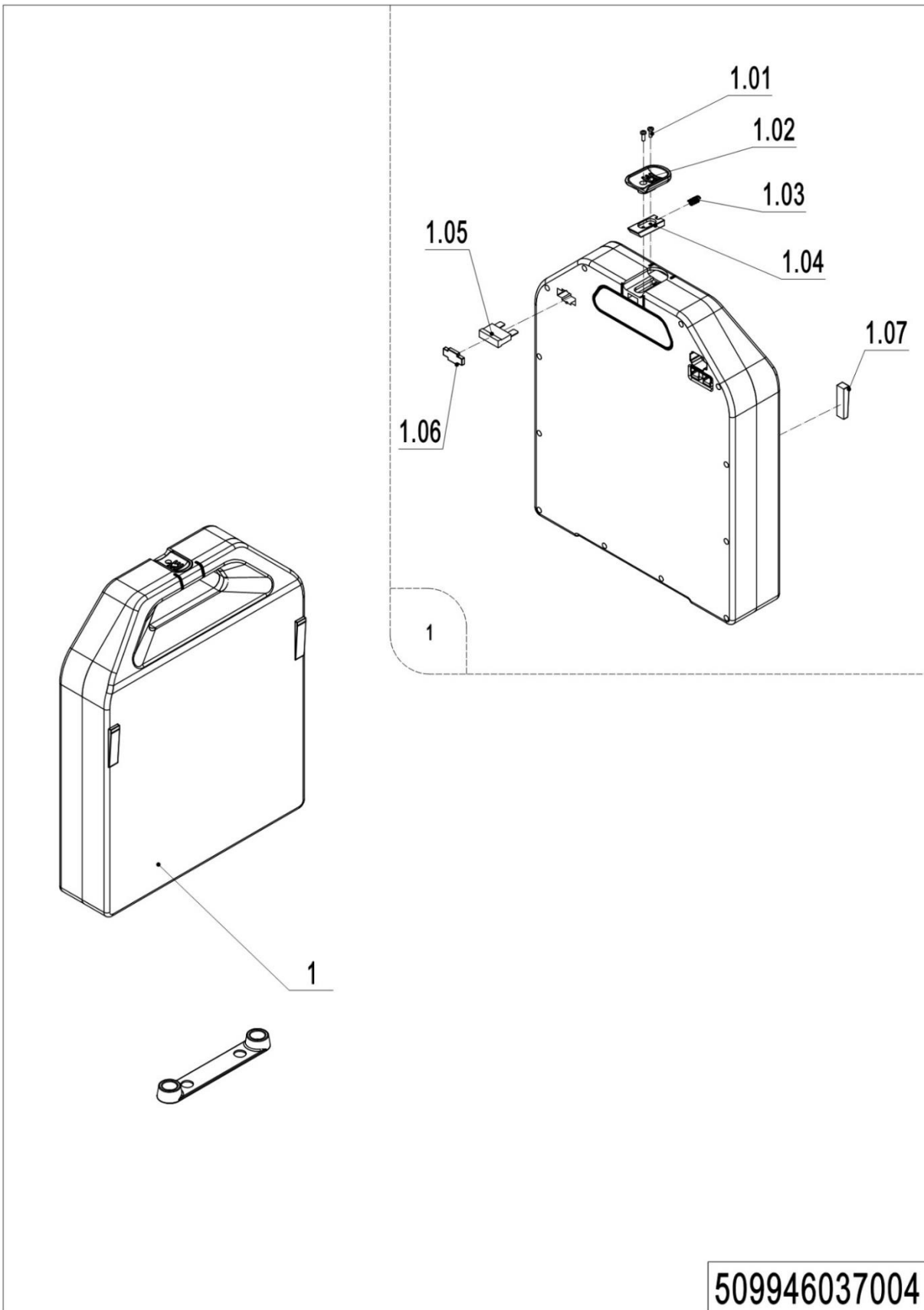
06 Traction Battery (509946037004)**509946037004**

1=整包供货

2=限制供货

3=逐渐停止供货

4=不单件供货

5=见另外表单

06 Traction Battery (509946037004)

No.	Item Code	Mark	Item Description	Qty.	Substitute	Note
1	509937010012		Li Battery48V20Ah	1		HF
1	509937010023		Li Battery48V20Ah	1		EN1175
1.01	910200500011	1	Screw	2		
1.02	508098520022	2	Plastic Handle	1		
1.03	508098520024	2	Spring	1		
1.04	508098520023	2	Fixing Mount	1		
1.05	920100200006		Fuse	1		
1.06	508098520021	2	waterproof plug	1		
1.07	509998520000		Stop Block	2		

Chapter 6: Others

01 Labels and Decals-EU (509946047001)

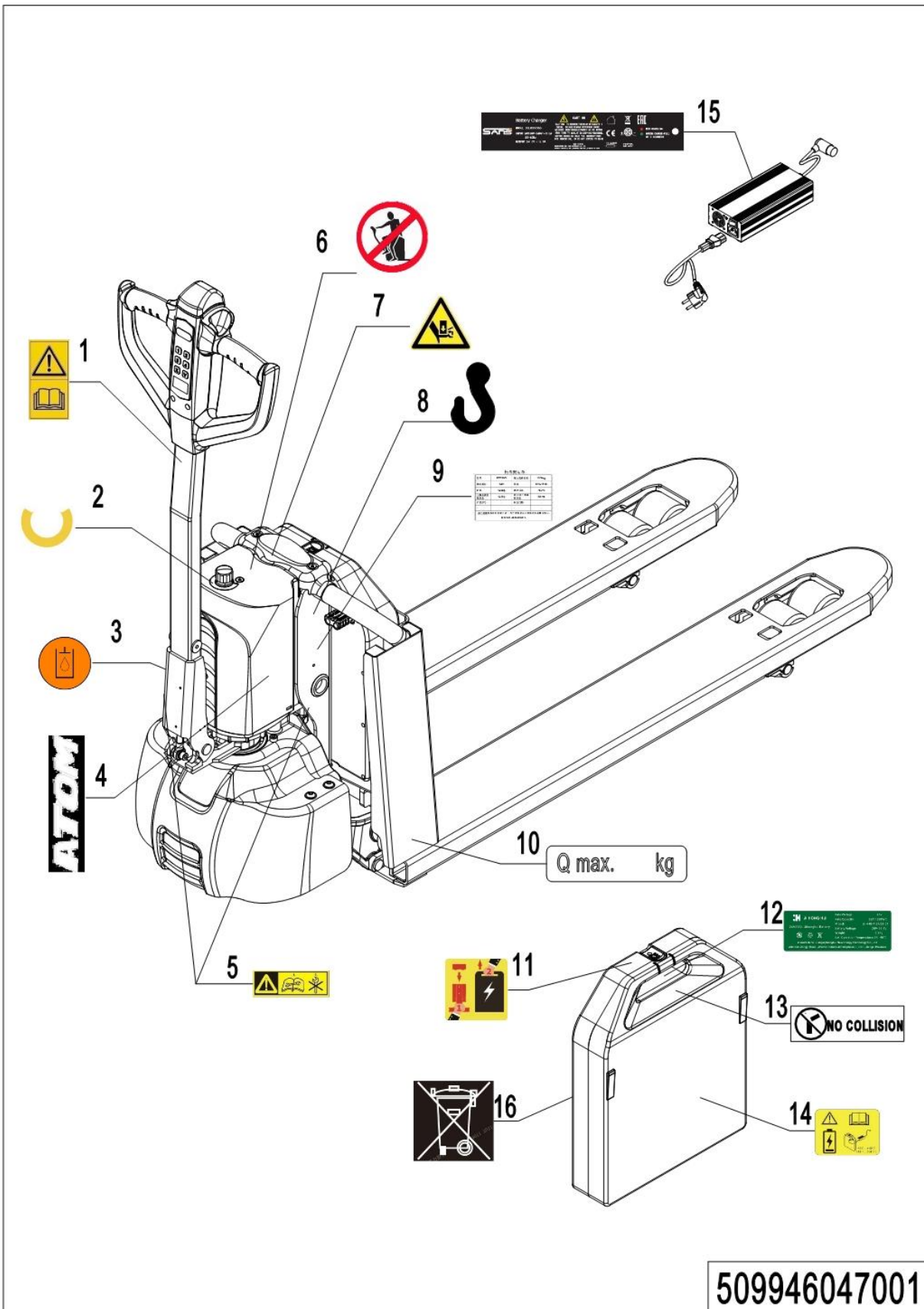

01 Labels and Decals-EU (509946047001)

No.	Item Code	Mark	Item Description	Qty.	Substitute	Note
1	941200300002		Label	1		
2	509947020000		Label	1		
3	941200300003		Label	1		
4	509947020001		Label	1		
5	508047020004		Label	2		
6	941200100003		Label	2		
7	508047020007		Label	1		
8	941200300001		Label	2		
9	509947520001		Truck data plate	1		
10	941200200010		Label	2		
11	509947020002		Label	1		
12	509947020007		Label	1		
13	508047020002		Label	1		
14	509947020004		Label	1		
15	509947020005		Label	1		
16	508047020015		Label	1		

02 Labels and Decals-US (509946047002)

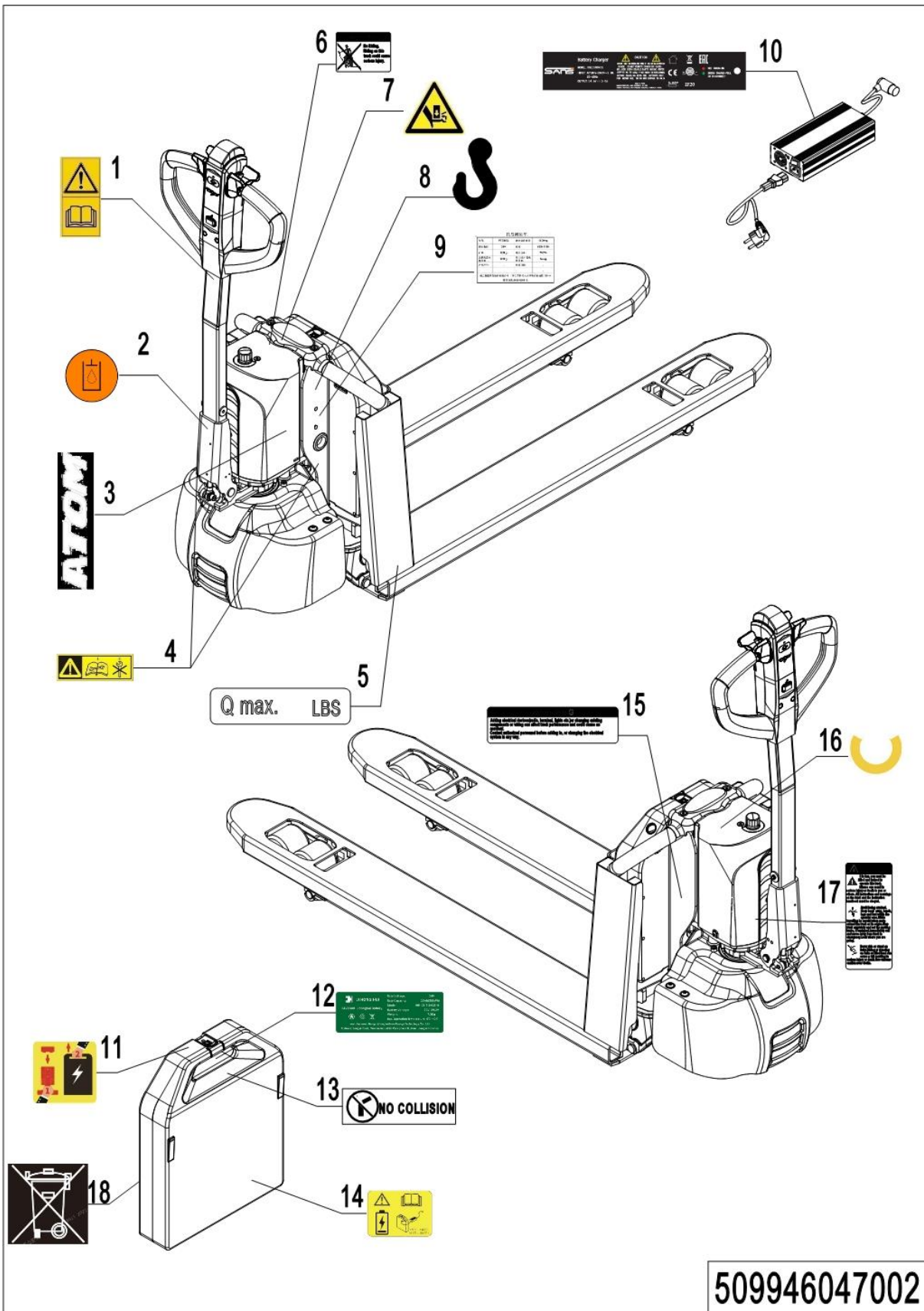

02 Labels and Decals-US (509946047002)

No.	Item Code	Mark	Item Description	Qty.	Substitute	Note
1	941200300002		Label	1		
2	941200300003		Label	1		
3	509947020001		Label	1		
4	508047020004		Label	2		
5	941200200009		Label	2		
6	941200100011		Label	1		
7	508047020007		Label	1		
8	941200300001		Label	2		
9	509947520001		Truck data plate	1		
10	941200200010		Label	1		
11	509947020002		Label	1		
12	509947020007		Label	1		
13	508047020002		Label	1		
14	509947020004		Label	1		
15	941200100010		Label	1		
16	509947020000		Label	1		
17	941200100009		Label	1		
18	508047020015		Label	1		

1=整包供货

2=限制供货

3=逐渐停止供货

4=不单件供货

5=见另外表单

Appendix

01 Electrical Circuit Diagram (509946045506)

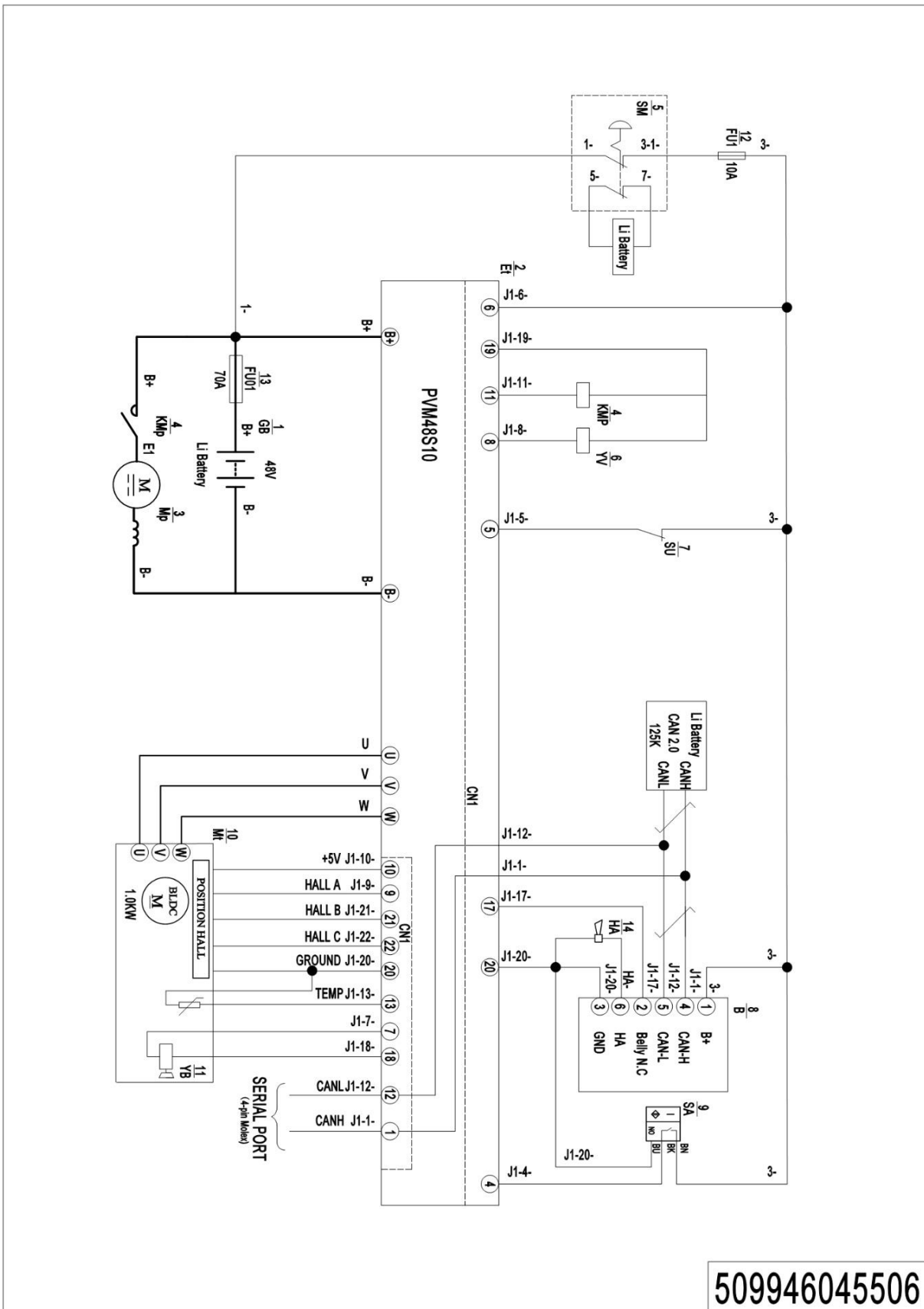

509946045506

1=整包供货 2=限制供货 3=逐渐停止供货 4=不单件供货 5=见另外表单

02 Electrical Circuit Diagram (509946045507)

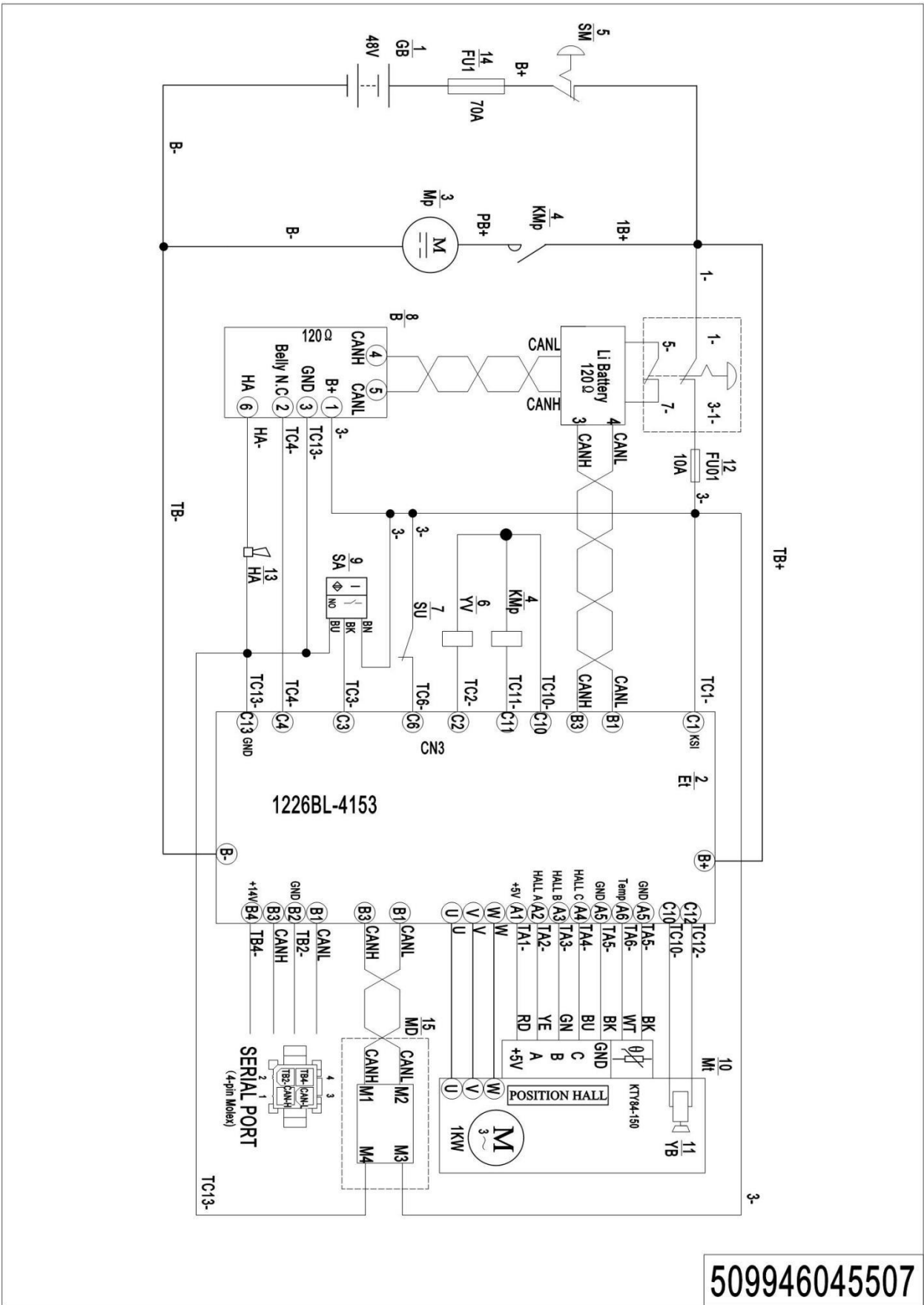

509946045507

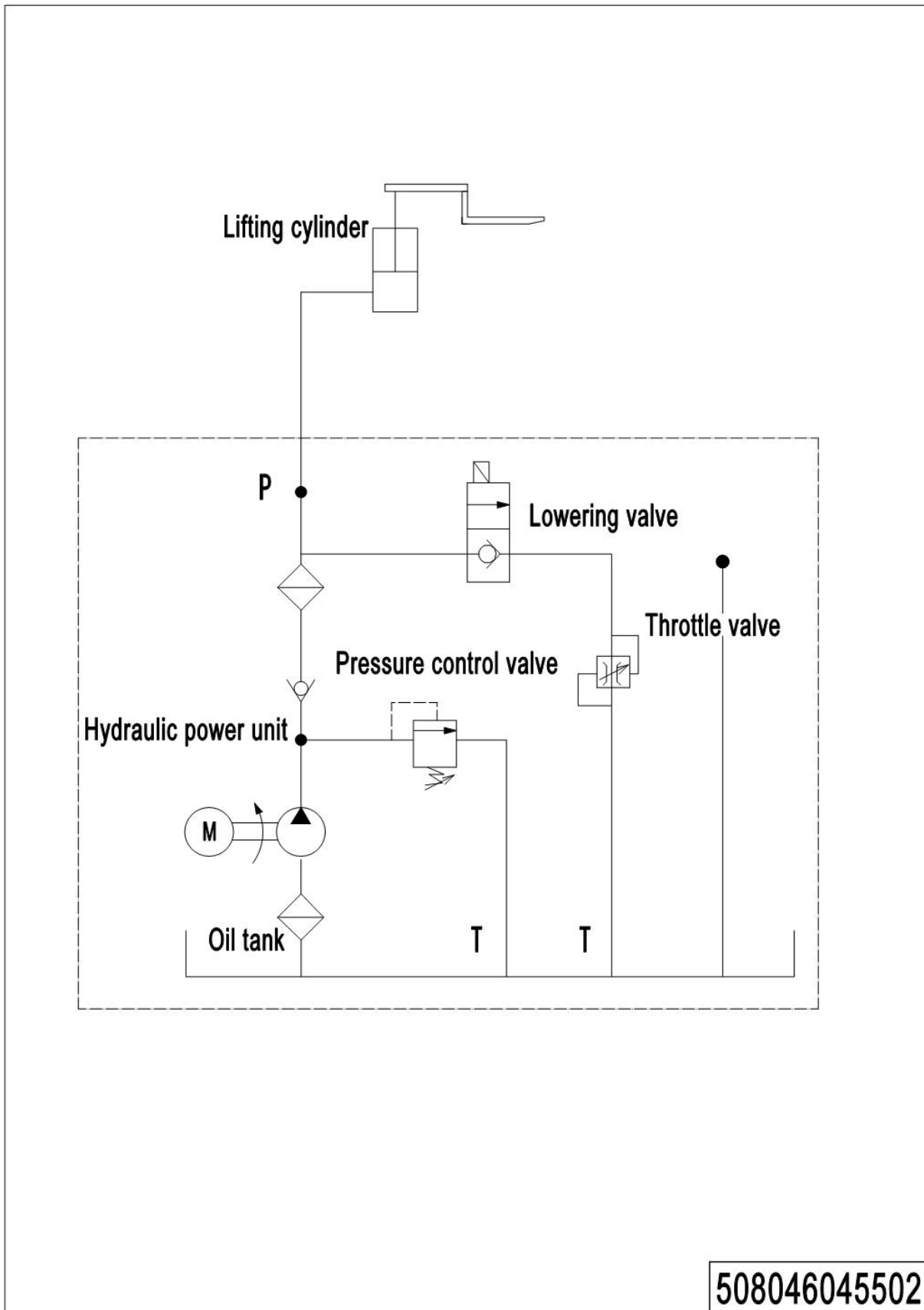
03 Hydraulic Circuit Diagram (508046045502)

04 Consumable Parts List

No.	Item Code	Item Description	Qty.	Chapter/ Section/ Number
1	910700200058	Bearing	1	Chapter1/01/4
2	910700600044	Bearing	1	Chapter1/01/7
3	961001300010	Wheel	1	Chapter1/02/9
4	910700200044	Bearing	2	Chapter1/02/10
5	910700200057	Bearing	1	Chapter1/02/22
6	910700200046	Bearing	1	Chapter1/02/24
7	508098510018	Seal Kit	1	Chapter2/01/12. 01 Chapter2/02/12. 01
8	508598510004	Seal Kit	1	Chapter2/01/12. 03 Chapter2/02/12. 03
9	940500100097	Bushing	2	Chapter3/01/11. 01Chapter2/02/15. 01
10	940500100083	Bushing	8	Chapter3/01/11. 05Chapter2/02/15. 04
11	940500200001	Bushing	2	Chapter4/01/06
12	508011010001	Gas Spring	1	Chapter4/01/10. 3
13	940500200038	Bushing	4	Chapter4/04/2. 01
14	910700200019	Bearing	8/4	Chapter4/04/2. 04
15	940300300047	Wheel Φ 80x70	4	Chapter4/04/2. 05
16	940500100088	Bushing	4	Chapter4/04/2. 09
17	940300300023	Wheel Φ 80x93	2	Chapter4/04/3. 01
18	910700200018	Bearing	4	Chapter4/05/6. 01
19	940300300017	Wheel Φ 80x30	2	Chapter4/05/6. 02
20	920100200006	Fuse	1	Chapter 5/06/1. 05