

NOBLELIFT



Scan it, for more
Information

INSTRUCTION MANUAL

Electric Pallet Truck

PWB-150/200

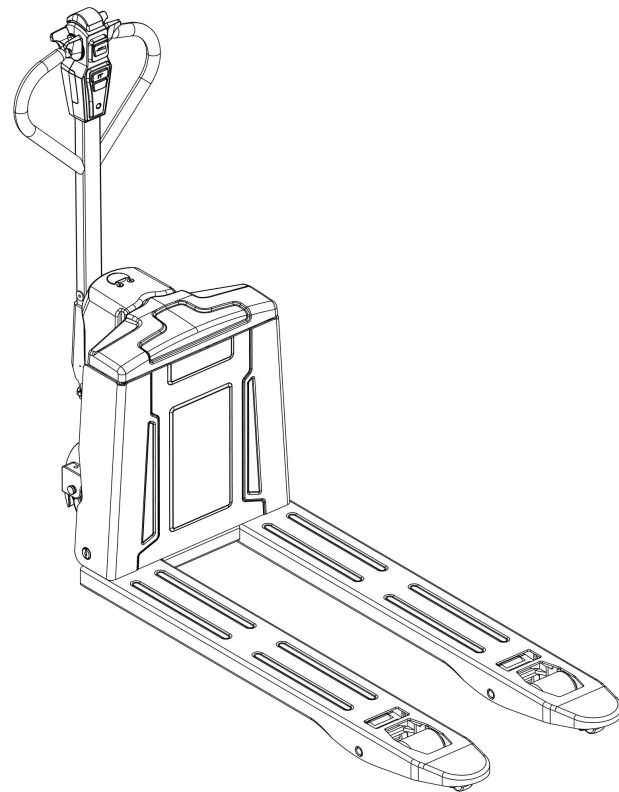

WARNING

Do not use the pallet truck before reading and understanding these operating instructions.

NOTE:

- Please check the designation of your present type at the last page of this document as well as on the ID-plate.
- Keep for future reference.

Version 08/2024

PWB-150/200-SMS-002-EN

FOREWORD

Before operating the truck, read this ORIGINAL INSTRUCTION MANUAL carefully and understand the usage of the truck completely. Improper operation could create danger.

This manual describes the usage of different electric pallet trucks. When operating and servicing the truck, make sure, that it applies to your type.

Keep this manual for future reference. If this or the warning/ caution labels are damaged or get lost, please contact your local dealer for replacement.

This truck complies with the requirements according to EN 12895 (Industrial trucks- electromagnetic compatibility), EN 12053 (Safety of industrial trucks- test methods for measuring noise emissions), assumed the truck is used according to the described purpose.

ATTENTION:

- Environmentally hazardous waste, such as batteries, oil and electronics, will have a negative effect on the environment, or health, if handled incorrectly.
- The waste packages should be sorted and put into solid dustbins according to the materials and be collected disposal by local special environment protection bureau. To avoid pollution, it's forbidden to throw away the wastes randomly.
- To avoid leaking during the use of the products, the user should prepare some absorbable materials (scraps of wooden or dry duster cloth) to absorb the leaking oil in time. To avoid second pollution to the environment, the used absorbable materials should be handed in to special departments in terms of local authorities.
- Our products are subject to ongoing developments. Because this manual is only for the purpose of operating /servicing the pallet truck, therefore please have understanding, that there is no guarantee out of particular features out of this manual.



NOTE: In this manual, the left symbol indicates warning and danger, which may lead to death or serious injury if not followed.

Copyright

The copyright remains with the company, mentioned on the CE- certificate at the end of this document or, if sold within the USA, with the company, mentioned on the company sticker.

TABLE OF CONTENTS

CORRECT APPLICATION	3
1. DESCRIPTION OF THE PALLET TRUCK	4
a. Overview of the main components	4
b. Technical data	5
c. Description of the safety devices and warning labels (Europe and other, excepting USA)	7
d. Identification plate	8
2. WARNINGS, RESIDUAL RISK AND SAFETY INSTRUCTIONS	8
3. COMMISSIONING, TRANSPORTING, DECOMMISSIONING	9
a. Commissioning	9
b. Hoisting/ transportation	9
c. Decommissioning	10
4. DAILY INSPECTION	10
5. OPERATING INSTRUCTIONS	11
a. Parking	11
b. Lifting	11
c. Lowering	12
d. Travelling	12
e. Steering	13
f. Braking	13
g. Malfunctions	13
h. Emergency	13
6. BATTERY SAFETY, CHARGING AND REPLACEMENT	13
a. Safety Instructions	14
b. Matters requiring attention	15
c. Replacement	16
d. Tiller panel	16
e. Charging	17
7. REGULAR MAINTENANCE	18
a. Maintenance checklist	19
b. Lubricating points	20
c. Check and refill hydraulic oil	21
d. Checking electrical fuses	21
8. TROUBLE SHOOTING	22
9. WIRING/ CIRCUIT DIAGRAM	23
a. Electrical circuit diagram	23
b. Hydraulic circuit diagram	27

CORRECT APPLICATION

It is only allowed to use this electric pallet truck according to this instruction handbook.

The trucks described in this handbook are self-propelled electric power pallet trucks. The trucks are designed to lift, lower and transport palletized loads.

A wrong usage can cause human injuries or can damage equipment.

The operator/ the operating company has to ensure the correct usage and has to ensure, that this pallet truck is used only by staff, which is trained and authorized to use this truck.

The pallet truck has to be used on substantially firm, smooth, prepared, level and adequate surfaces. The truck is intended to be used for indoor applications with ambient temperatures between +5°C and +40°C and for various transportation applications without crossing permanent obstacles or potholes. The work on ramps is allowed if ramp is not exceeding the allowed angle. While operating, the load must be placed approximately on the longitudinal center plane of the truck.

Lifting or transporting people is forbidden.

If used on tail lifts or loading ramps, please ensure that these are used correctly according to the operating instructions.

The capacity is marked on capacity sticker as well on the Identification plate. The operator has to consider the warnings and safety instructions.

Operating lighting must be minimum 50 Lux.

Modification

No modifications or alterations to this pallet truck which may affect, for example, capacity, stability or safety requirements of the truck, shall be made without the prior written approval of the original truck manufacturer, its authorized representative, or a successor thereof. This includes changes affecting, for example braking, steering, visibility and the addition of removable attachments. When the manufacturer or its successor approve a modification or alteration, they shall also make and approve appropriate changes to capacity plate, decals, tags and operation and maintenance handbooks.

By not observing these instructions, the warranty becomes void.

1. DESCRIPTION OF THE PALLET TRUCK

a. Overview of the main components

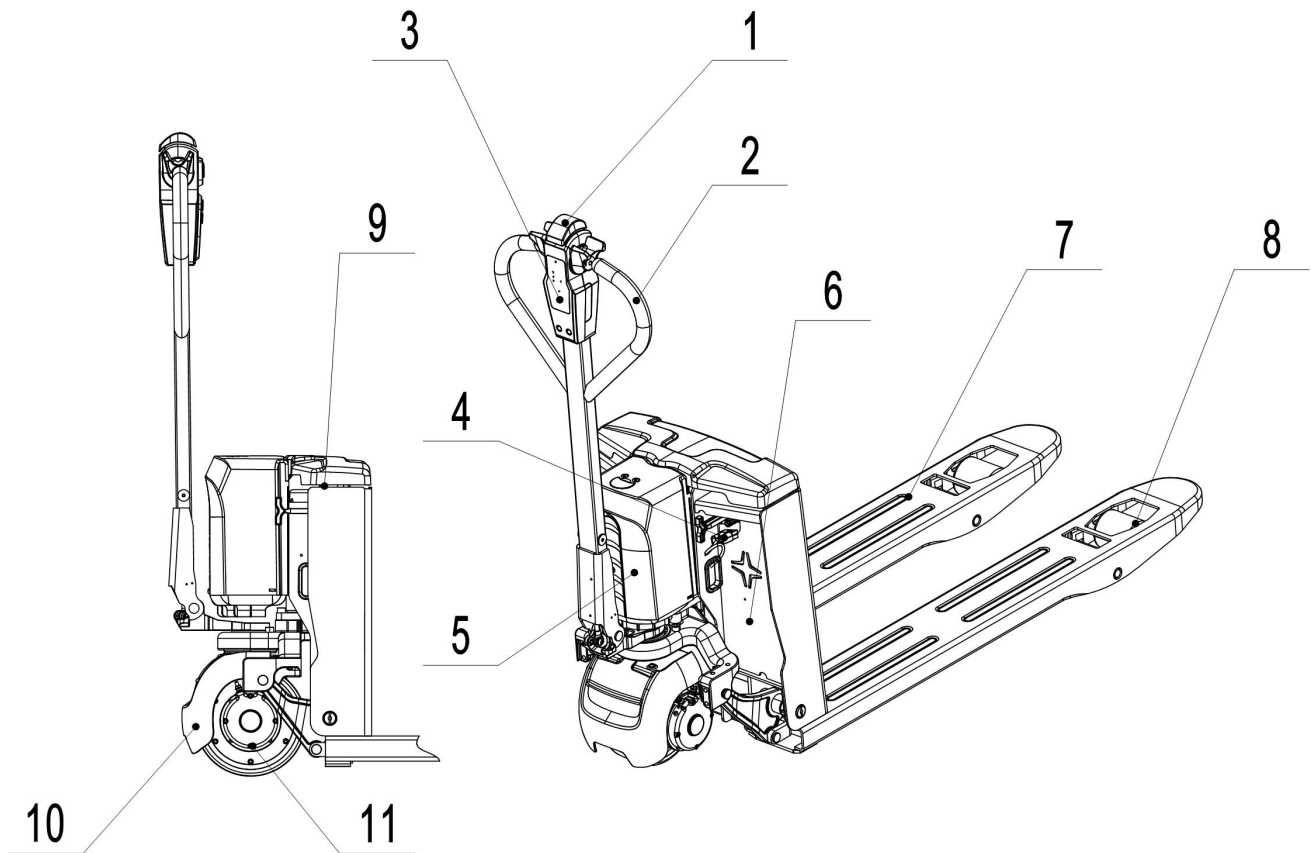

Fig. 1: Overview of the main components

- | | |
|---------------------------------|----------------|
| 1. Safety (belly) button | 7. Fork |
| 2. Tiller | 8. Load roller |
| 3. Discharge charging indicator | 9. Battery |
| 4. Battery connector plug | 10. Apron |
| 5. Plastic cover | 11. Drive unit |
| 6. Chassis | |

b. Technical data

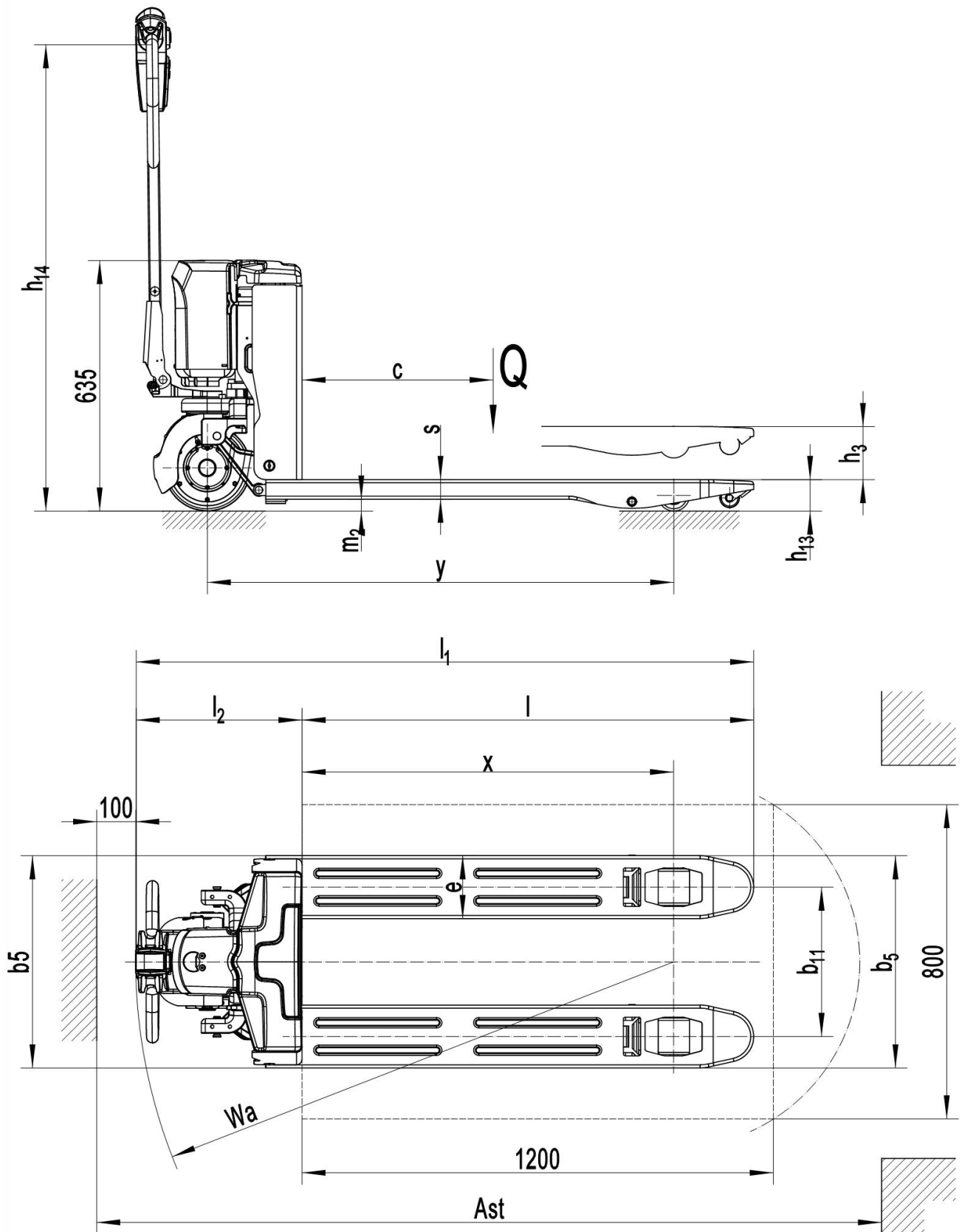

Fig. 2: Technical data

Table 1: Main technical data for standard version

Type sheet for industrial truck acc. to VDI 2198							
Distinguishing mark	1.2	Manufacturer's type designation		PWB-150		PWB-200	
	1.3	Drive: electric (battery type, mains, ...), diesel, petrol, fuel gas		Battery			
	1.4	Operator type: hand, pedestrian, standing, seated, order-picker		Pedestrian			
	1.5	Rated capacity/ rated load	Q (t)	1.5		2.0	
	1.6	Load centre distance	c (mm)	600			
	1.8	Load distance, centre of drive axle to fork	x (mm)	947			
	1.9	Wheelbase	y (mm)	1189			
Weight	2.1	Service weight	kg	130	140	139	148
	2.2	Axle loading, laden front/ rear	kg	520 / 1110	525 / 1115	525/1114	528/1120
	2.3	Axle loading, unladen front/ rear	kg	99 / 31	108/32	107/32	114/34
Tyres/ chassis	3.1	Tires		Polyurethane (PU)			
	3.2	Tire size, front	∅ x w (mm)	∅ 210×75			
	3.3	Tire size, rear	∅ x w (mm)	∅ 80×60/(∅ 80×83)			
	3.4	Wheels, number front/ rear(x=driven wheels)		1x/ 2(1x/ 4)			
	3.6	Tread, rear	b ₁₁ (mm)	380	525	380	525
Dimensions	4.4	Lift	h ₃ (mm)	115			
	4.9	Height drawbar in driving position min./ max.	h ₁₄ (mm)	630/ 1230			
	4.15	Height, lowered	h ₁₃ (mm)	80			
	4.19	Overall length	l ₁ (mm)	1530			
	4.20	Length to face of forks	l ₂ (mm)	380			
	4.21	Overall width	b ₁ (mm)	540	685	540	685
	4.22	Fork dimensions DIN ISO 2331	s/e/ l (mm)	50 / 160 / 1150			
	4.25	Fork spread	b ₅ (mm)	540	685	540	685
	4.32	Ground clearance, centre of wheelbase	m ₂ (mm)	30			
	4.34	Aisle width for pallets 800×1200 lengthways (safe distance 200)	A _{st} (mm)	2005			
4.35	Turning radius	W _a (mm)	1332				
Performance	5.1	Travel speed, laden/ unladen	km/h	4.2/4.3		4.2/4.6	
	5.2	Lift speed, laden/ unladen	m/s	0.017/0.024		0.015/0.020	
	5.3	Lowering speed, laden/ unladen	m/s	0.072/0.047		0.033/0.024	
	5.8	Max. gradeability, laden/ unladen	%	6 / 20		7 / 20	
	5.10	Service brake		Electromagnetic Brake			
Electric-engine	6.1	Drive motor rating S2 60min	kW	0.75		1.0	
	6.2	Lift motor rating at S3 10%	kW	0.50		0.8	
	6.3	Battery acc. to DIN 43531/35/36 A, B, C, no		No			
	6.4	Battery voltage/ nominal capacity K ₅	(V)/(Ah)	24 / 20 (24 / 40;24 / 60)		48 / 10(48 / 20)	
	6.5	Battery weight (+/-5%)	kg	5.9		6	

	6.6	Energy consumption acc. to VDI	kWh/h	0.188	0.264
Additional data	8.1	Type of drive unit		DC	
	8.4	Sound level at driver's ear acc. to EN 12053	dB(A)	<70	

c. Description of the safety devices and warning labels (Europe and other, excepting USA)

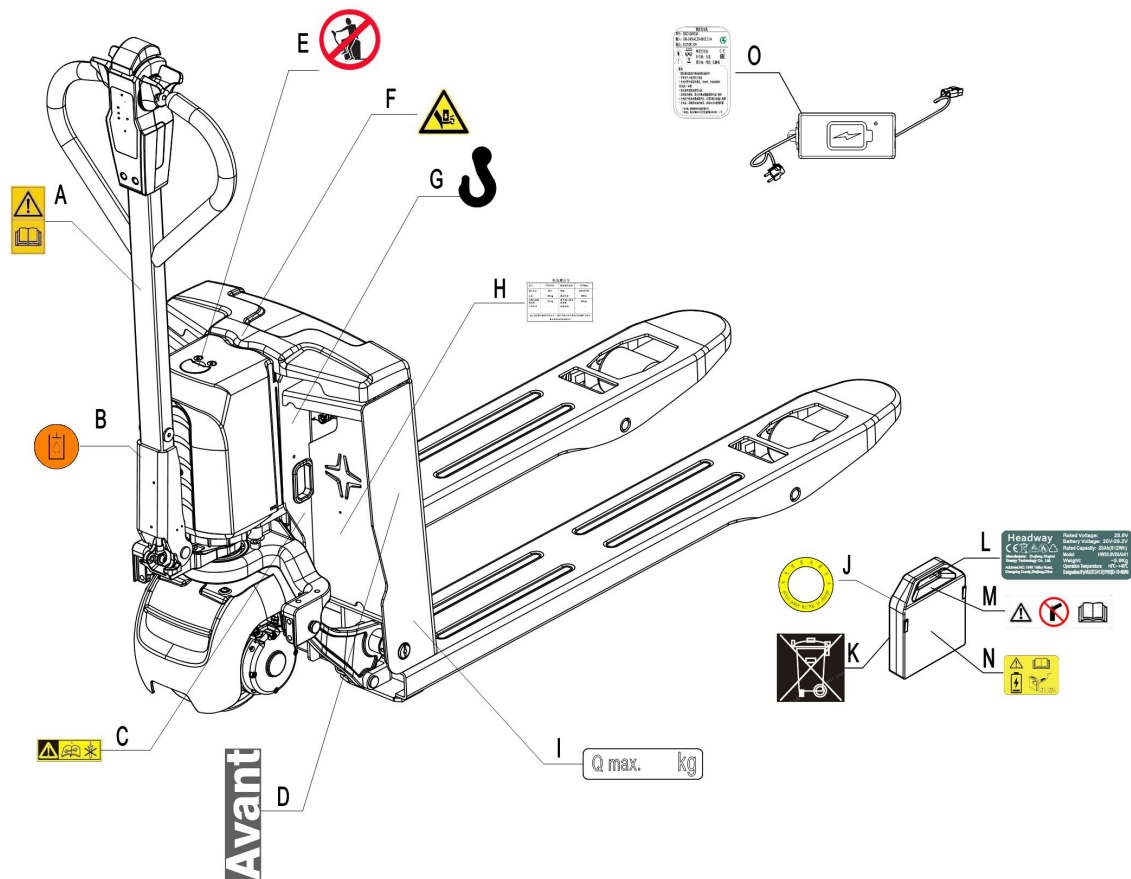

Fig. 3: Safety and warning labels

- | | |
|--|---------------------------------------|
| A. Sticker to read and follow this instruction | I. Capacity label |
| B. Sign oil filling point | J. Warning sticker (operation steps) |
| C. Sticker to read and follow maintenance manual | K. Sticker (do not discard the label) |
| D. Decal | L. Battery ID plate |
| E. "No passengers" decal | M. No collision sticker |
| F. Warning sticker (hands pinching) | N. Battery warning sticker |
| G. Crane hook label | O. Charger ID plate |
| H. Identification plate (ID-plate) | |

The truck is equipped with an emergency switch (4) which stops all lifting-, lowering-, driving- functions and engages the fail-safe electromagnetic brake when it is pulled and disconnected.

The truck is equipped with a safety (belly) button (1) which switches the driving function away from the

operator, if the truck travels towards the operator and the tiller is activated in the tillers operating zone. Follow also the instructions given on the labels and decals. Replace the label and decals in time if they are damaged or missing.

d. Identification plate

Pallet Truck			
Type	xxxx	Rated capacity	xxxx kg
Rated voltage	xx V	Service weight without battery	xxxx kg
Battery weight maximum	xxx kg	Battery weight minimum	xxx kg
Net weight (without load and battery)	xxx kg	Lift height maximum	xxxx mm
Serial number	XXXXXXXXXX	Equipment code	XXXXXXXXXX
Manufacturing Name XXXXXXXXXXXXXXXXXXXX Manufacturing Address XXXXXXXXXXXXXXXXXXXX			

Fig. 4: Identification plate

Check the ID plate taped on the truck for contents and type.

2. WARNINGS, RESIDUAL RISK AND SAFETY INSTRUCTIONS



DO NOT

- Put foot or hand under or into the lifting mechanism.
- Allow other person than the operator to stand in front of or behind the truck when it is moving or lifting/lowering.
- Overload the truck.
- Put foot in front of the wheels, injury could result.
- Lift people. People could fall down and suffer severe injury.
- Push or pull loads
- Side or end load. Load must be distributed evenly on the forks.
- Use the truck with unstable or unbalanced load.
- Use truck without manufacturer's instructions manual.
- Lifted loads could become unstable at wind forces. In the case of wind forces do not lift the load if there is any influence to the stability.

Watch difference in floor levels when driving. Load could fall down or the truck could get uncontrollable.

Keep watching the condition of load. Stop operating the truck if load becomes unstable.

Brake the truck and activate the emergency switch (4) by pushing when sliding load on or off the truck. If the truck has any malfunctions, follow chapter 10.

Practice maintenance work according to regular inspection. This truck is not designed to be water resistant. Use the truck under dry condition. Prolonged continuous operation might cause damage of the power pack. Stop operation if temperature of hydraulic oil is too high.



- When operating the electric pallet truck, the operator has to wear safety shoes.
- The truck is intended to be used for indoor applications with ambient temperatures between +5°C and + 40°C.
- The operating lighting must be minimum 50 Lux.
- To prevent unintended sudden movements when not operating the truck (i.e. from another person, etc.), disconnect the power.

3. COMMISSIONING, TRANSPORTING, DECOMMISSIONING

a. Commissioning

Table 2: Commissioning data

Type	PWB-150	PWB-150	PWB-200	PWB-200
Commissioning weight [kg]	130kg	140kg	139	148
Dimensions [mm]	1530x540x1300	1530x685x1300	1530x540x1300	1530x685x1300

After receiving our new pallet truck or for re-commissioning you have to do the following before (firstly) operating the truck:

- Check if are all parts included and not damaged
- Make sure the tiller is assembled correctly (electrical socket is connected and fixed with two plastic clamps, circlip of the axle is installed)
- Check that battery is charged (follow chapter 8)
- Do the work according to the daily inspections as well as functional checks.

b. Hoisting/ transportation

For transporting, remove the load, lower the forks to the lowest position and fix the truck safely with dedicated hoisting equipment according to the following figures.

Hoisting



USE DEDICATED CRANE AND HOISTING EQUIPMENT
DO NOT STAND UNDER THE SWAYING LOAD
DO NOT WALK INTO THE HAZARDOUS AREA DURING HOISTING

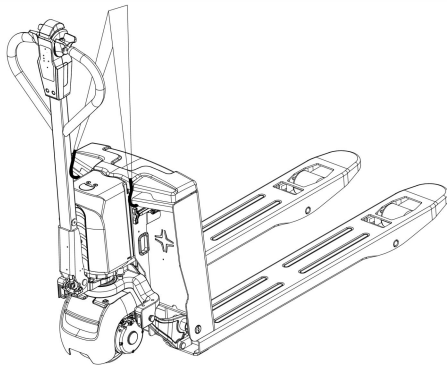

Fig. 5: Hoisting with a crane

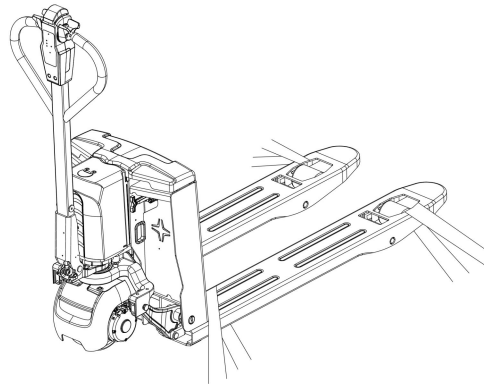

Fig. 6: Fixing points

Transportation



ALWAYS FASTEN THE TRUCK SECURELY DURING TRANSPORTATION ON A TRANSPORT VEHICLE

Lower the forks and park the truck securely.

Fasten the truck according to Fig. 6 by fixing dedicated lashing belts to each side of the trucks crane hook holes and fasten the other side at the transporting truck.

c. Decommissioning

For storage, remove the load, lower the truck to the lowest position, grease all in this handbook mentioned greasing points (regular inspection), and eventually protect the truck against corrosion and dust. Remove the batteries and jack the truck safely, so that there will be no flattening after storage.

For final decommissioning hand the truck to a designated recycling company. Oil, batteries and electric components must be recycled due to legal regulations.

4. DAILY INSPECTION

This chapter describes pre-shift checks before putting the truck into operation.

Daily inspection is effective to find the malfunction or fault on this truck. Check the truck on the following points before operation.

Remove load from truck and lower the forks.



DO NOT USE THE TRUCK IF ANY MALFUNCTION IS FOUND.

- Check for scratches, deformation or cracks.
- Check if there is any oil leakage from the cylinder.
- Check the smooth movement of the wheels.
- Check the function of driving with tiller in its vertical position.
- Check the function of the emergency brake by activating the emergency switch.
- Check the braking function of the proximity switch of the tiller.
- Check the lifting and lowering functions by operating the buttons.
- Check if all bolts and nuts are tightened firmly.
- Visual check if there are any broken electric wires.

5. OPERATING INSTRUCTIONS



BEFORE OPERATING THIS TRUCK, PLEASE FOLLOW THE WARNINGS AND SAFETY INSTRUCTIONS (CHAPTER 3).

Make sure, that the load is palletized and stable and that the daily inspection is carried out.

Turn on the power and start the vehicle.

Press the horn button (Fig.7, 13) to activate the audible warning signal.

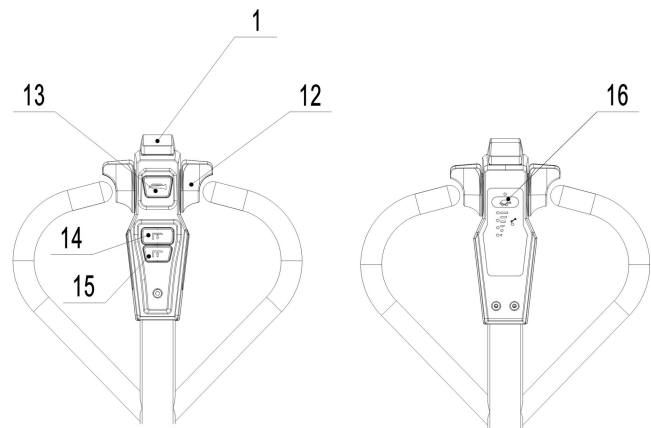

Fig.7: Control handle

a. Parking



DO NOT PARK THE TRUCK ON INCLINED SURFACES

The truck is equipped with an electromagnetic fail-safe stopping and parking brake. Always lower the forks fully and disconnect the power.

b. Lifting



DO NOT OVERLOAD THE TRUCK!
THE MAXIMUM CAPACITY OF
PWB-150 IS 1500KG.

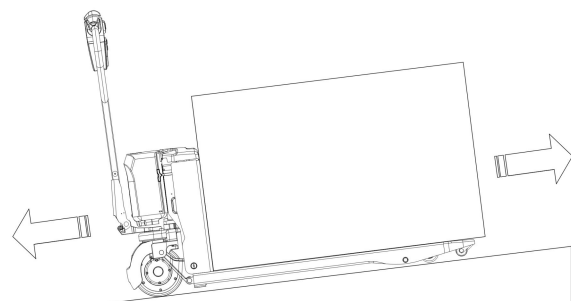

Fig. 8: Load facing uphill

Travel with the lowered forks fully underneath the pallet and press the lifting button (Fig. 7, 14) until you reach the desired lifting height.

c. Lowering

Press the lowering button (15) carefully.

Lower the load until the forks are clear of the pallet, then drive the truck carefully out of the load unit.

d. Travelling



TRAVEL ON INCLINES ONLY WITH THE LOAD FACING UPHILL.

DO NOT TRAVEL ON INCLINES MORE THAN SPECIFIED WITH THE TECHNICAL DATA.

Start the vehicle and move the tiller to the operating zone ('F', Fig.9).

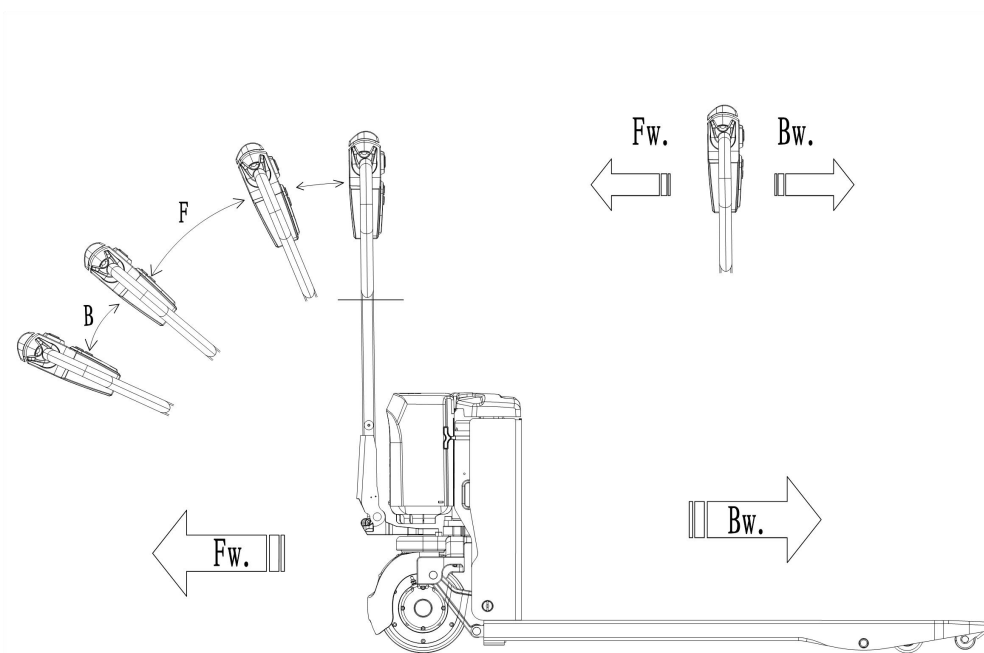

Fig. 9: Operating direction

Turn the accelerator knob to the desired direction forward 'Fw.' or backwards Bw.'(Fig. 9).

Control the travelling speed by operating the accelerator knob (Fig.7,12) carefully until you reach the desired speed.

If you move the accelerator knob back to the neutral position, the controller will decelerates the truck until the truck stops. If the truck stops, the parking brake will be engaged.

Drive the truck to the destination carefully. Watch the route conditions and adjust the travelling speed by

operating the accelerator.

Press turtle button (Fig.7,16) to enter into slow speed mode, travel slowly by operating the accelerator knob (Fig.7,16), press turtle button again to switch to regular speed mode.

Press the turtle button and hold it for 2 seconds to activate driving function with tiller in vertical position when operating in confined areas. Release the turtle speed button to exit upright walking mode.

e. Steering



Steer the truck by moving the tiller to the left or right side.

f. Braking



PLEASE CHECK THE BRAKING DISTANCE WITH TRUCK BEFORE OPERATION
THE BRAKING PERFORMANCE DEPENDS ON THE TRACK CONDITIONS AND
THE LOAD CONDITIONS OF THE TRUCK

The braking function can be activated in several ways:

- By moving the accelerator knob (14) to the initial '0' position or by releasing the knob, the regenerative braking is activated. The truck brakes until it stops.
- By moving the accelerator knob (14) from one driving direction directly to the opposite direction, the regenerative braking is activated until the truck starts traveling into the opposite direction.
- The truck brakes, if the tiller is located in the braking zones ('B'). If the tiller is released, the tiller moves automatically to the upper braking zone ('B'). The truck brakes until it stops.

The safety (belly) button (1) prevents the operator from crush. If this button is activated, the truck decelerates and/or starts traveling into backwards direction ('Bw.') for a short distance and stops then. Please consider that this button still works if the truck is not traveling with tiller in operating zone.

g. Malfunctions

If there are any malfunctions or the truck is inoperative, please stop using the truck. If possible, park the truck in a safe area and cutting off the power. Inform immediately the manager or call your service. If necessary, move the truck out of the operating area by using dedicated towing/ hoisting equipment.

h. Emergency

In emergencies or in the event of tipping over (or fall off a dock), keep a safe distance immediately. If possible, push the emergency button (4) and all electrical functions will be stopped.

6. BATTERY SAFETY, CHARGING AND REPLACEMENT



- Only qualified personnel are allowed to service or charge the batteries. The

instructions of this handbook must be observed.

- The batteries are lithium batteries.
- Recycling of batteries undergoes national regulations. Please follow these regulations.
- By handling batteries, open fire is prohibited!
- In the area of battery charging neither burning materials nor burning liquids are allowed. Smoking is prohibited and the area must be ventilated.
- Park the truck securely before starting charging or installing/changing the batteries
- Before finishing the maintenance work, make sure, that all cables are connected correctly and that they are no disturbing towards other components of the truck.

Table 3: Available batteries

Model	Battery specification
PWB-150	24V20Ah lithium battery, 5.9kg
PWB-200	48V10Ah lithium battery, 5.3kg



IT IS ONLY ALLOWED TO USE LITHIUM BATTERIES.

PLEASE CONSIDER THE MAXIMUM OPERATING TEMPERATURE OF THE BATTERIES AND REFER TO SAFETY INSTRUCTIONS BELOW

a. Safety Instructions

Failure to follow the below requirements may cause damage to your property, cause injuries or death.

Measures to prevent ignition

- It is forbidden to work at temperatures over 60 °C.
- It is forbidden to place it beside heat sources, such as stoves, fireplaces, etc.
- Direct sunlight must be avoided.
- It is forbidden to place batteries near inflammable and explosive substances.

Measures to prevent explosion

- Do not hit the battery, no impacts are allowed.
- Exclude penetration of objects through battery case or damages to battery case
- DO not throw products into the fire or water.

Measures to prevent electric leakage

- Do not disassemble.
- Do not contact by wet hands.
- Do not expose it to moisture or liquids.
- Do not place batteries in a place of easy access by children or animals.

Measures to preventing damage to battery systems

- It is forbidden to contact liquids or corrosive chemicals.
- Do not expose batteries to high temperature and/or high pressure.
- No trampling, disassembly or smashing.
- Do not attempt charging from discharge terminals and discharging from charging terminals.

Installation environment

In order to ensure the best operating performance, the battery need to be kept under normal working conditions: between 0 and 40 degrees Celsius and normal humidity. Avoid excessive temperature

difference on both sides of the battery (more than 5°C).

Emergency management

Below are examples of several ways to deal with possible emergencies:

- In case of Smoke or Ignition: stop to use equipment immediately, take appropriate actions according to working instructions and stay away from the scene.
- In case battery is immersed in water: stop to use equipment immediately, take appropriate actions according to working instructions and stay away from the scene.
- Products produce smell: stop to use equipment immediately, remove the battery and take appropriate actions according to working instructions and stay away from the scene. Avoid contact with any leaking liquids or gases out of the battery (in case of contact clean immediately).

Necessary safety equipment

- Self-contained breathing apparatus and personal protective equipment.
- Sevofluoropropane fire extinguishing system.

b. Matters requiring attention

- The charging function of batteries may be blocked by Battery Management System if temperature of cells inside the battery case is lower than +5°C. Make sure the own temperature of battery is above this value and the temperature of the battery is even.
- Batteries are forbidden to charge at low temperatures, but they can be used in occasional low temperature environment (please refer to normal working conditions allowed for the truck), but their efficient capacity will be lower, which is a normal phenomenon.

Ambient temperature	Remaining discharge capacity of battery pack
25°C	100%
0°C	90%
-20°C	70%
-30°C	40%



Note: Although the battery can be discharged at very low temperature, it is easy to generate condensate during the charging process, which will damage the internal electronic devices of the battery and create unpredictable hidden dangers. Batteries cannot be charged until they are slowly warmed up to minimum allowed temperature for activation of charging function (may take up to 4 hours in normal temperature conditions). Forced warming up (e.g., using of heaters, vents etc.) is forbidden.

The dependence of actual capacity from environmental temperature is shown for reference only and can not be used as a commitment/allowance for low temperature operation, please refer to the Chapter 1 for correct application conditions.

- The battery protection level is IP40, so please do not wash the battery directly with water.
- When the lithium battery pack is not in use for a long time store it with 30-50% level of charge to extend its life-time.

- The vehicle is prohibited from driving, that is, when the handle power indicator flashes red, please charge in time, otherwise there is the risk of battery loss; It is recommended that the charging action be performed within 7 days when the driving state is prohibited.

c. Replacement

Park the truck securely and disconnect the battery connector plug to power off the truck. Open the battery cover and take out the battery vertically.

The installation is in the reverse order.

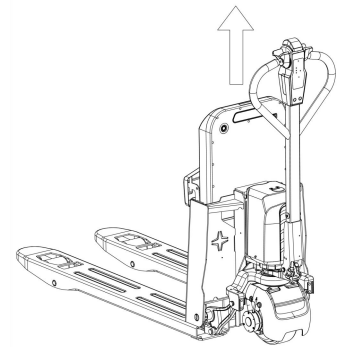

Fig. 10: Battery replacement

d. Tiller panel

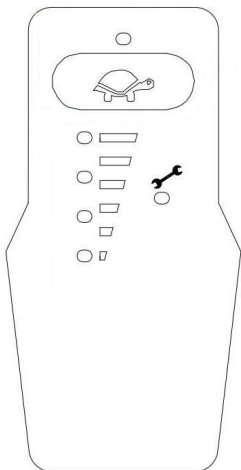
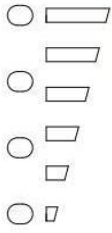

Fig. 11: Tiller panel

Fault Code

When a fault code is generated, firstly all four battery indicator lights are on, then the first (most left) battery indicator flashes and counts, then multiply this number by ten for the first number; then the fourth (most right) battery indicator flashes and counts the times for the second number; Plus these two numbers you will get the fault code.

Battery state of charge (SOC)



The battery's state of charge is indicated by 4 indicator lights. As the battery gradually discharges, the battery indicator lights turn on in sequence. When the green light is on, SOC is 75%-100%. When the blue light is on, SOC is 50%-75%. When the yellow light is on, SOC is 25%-50%, and when the red light is on, SOC is 0%-25%.

Turtle Symbol

The Turtle Symbol indicator is normally off, when the symbol appears (fixed), it shows activation of the “soft” mode of the truck, in which maximum speed and acceleration are reduced.

e. Charging



- Before charging ensure that you are using an appropriate charger for charging the installed battery and that all safety measures are taken into consideration.
- Before using the charger, please fully understand the instructions of the charger instructions.
- Always follow these instructions
- The room, where you are charging must be ventilated.
- The exactly charge status can be only checked from the discharge indicator. To control the status, the charging must be interrupted and the truck must be started.
- Do not make attempts to charge the battery if it is impacted and the battery case is damaged.

Park the truck at a dedicated secured area with a dedicated power supply.

Lower the forks and remove the load;

Switch the truck off and connect the charger power cord (18) to the socket of power supply, and connect the charger plug (19) to the charging socket (17) of the battery. The charger starts charging the battery.

If charging is completed, disconnect the charger from the battery and the power supply, then put the charger in the designated pocket.

It's also allowed to remove the battery out and charge in dedicated area.

If there is an optional second battery, the truck can continue to work after replacing the battery, and

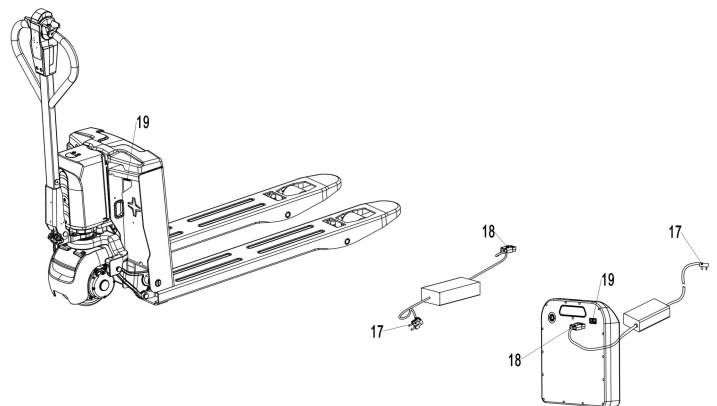

Fig.12: Battery charging

charge the battery that needs to be charged separately.

Table 4: LED-Status

LED - Signal	Function
Red	Charging
Green	Fully charged

Table 5: Charger (PWB-150/200)

PWB-150			
Model	Specification	Input	Output
SWCH24V10A	24V10A	100-240VAC,50-60HZ 1.5A	29.2VDC 10A
PWB-200			
Model	Specification	Input	Output
SWCH48V5A	48V5A	100-240VAC,50-60HZ 2.1A	54.6VDC 5A

7. REGULAR MAINTENANCE



- Only qualified and trained personnel are allowed to do maintenance on this truck.
- Before maintaining, remove the load from the forks and lower the forks to the lowest position.
- If you need to lift the truck, follow chapter 4 by using designated lashing or jacking equipment. Before working, put safety devices (for instance designated lift jacks, wedges or wooden blocks) under the truck to protect against accidental lowering, movement or slipping.
- Please pay attention by maintain the tiller arm. The gas pressure spring is pre-loaded by compression, carelessness can cause injury.
- Use approved and from your dealer released original spare parts.
- Please consider that oil leakage of hydraulic fluid can cause failures and accidents.
- It is allowed to adjust the pressure valve only from trained service technicians.

If you need to replace the wheels, please follow the instructions above. The casters must be round and free of abnormal wear.

Check the items emphasized in maintenance checklist.

a. Maintenance checklist

Table 6: Maintenance checklist

		Interval (Monthly)			
		1	3	6	12
Hydraulic					
1	Check the hydraulic cylinder for damage noise and leakage		•		
2	Check the hydraulic joints for damage and leakage		•		
3	Inspect the hydraulic oil level, refill if necessary		•		
4	Replace the hydraulic oil (12 month or 1500 working hours)				•
5	Check and adjust the pressure valve (1500kg (PWB-150)+0/+10%				•
Mechanical system					
6	Inspect the forks for deformation and cracks		•		
7	Check the chassis for deformation and cracks		•		
8	Check if all screws are fixed		•		
9	Check the push rods for deformation and damages		•		
10	Check the gearbox for abnormal sound and noise		•		
11	Inspect the wheels for deformation and damages		•		
12	Inspect and lubricate the steering bearing				•
13	Inspect and lubricate the pivot points if necessary		•		
14	Lubricate the grease nipples	•			
Electrical system					
15	Inspect the electric wiring for damage		•		
16	Check the electric connections and terminals		•		
17	Test the Emergency switch function		•		
18	Check the electric drive motor for noise and damages		•		
19	Test the display		•		
20	Check, if correct fuses are used		•		
21	Test the warning signal		•		
22	Check the contactor(s)		•		
23	Check the frame leakage (insulation test)		•		
24	Check function and mechanical wear of the accelerator		•		
25	Check the electrical system of the drive motor		•		
Braking system					
26	Check brake performance, if necessary, replace the brake disc		•		
Battery					
27	Check the battery voltage		•		
28	Clean the terminals for corrosion and damages		•		
29	Check the battery housing for damages		•		
Charger					
30	Check the main power cable for damages			•	
31	Check the start-up protection during charging			•	

Function				
32	Check the horn function	•		
33	Check the air gap of the electromagnetic brake	•		
34	Test the emergency braking	•		
35	Test the reverse and regenerative braking	•		
36	Test the safety (belly) button function	•		
37	Check the steering function	•		
38	Check the lifting and lowering function	•		
39	Check the tiller arm switch function	•		
General				
40	Check if all decals are legible and complete	•		
41	Inspect the castors, adjust the height or replace if worn out.		•	
42	Carry out a test run	•		

b. Lubricating points

Lubricate the marked points according to the maintenance checklist. The required grease specification is: DIN 51825, standard grease.

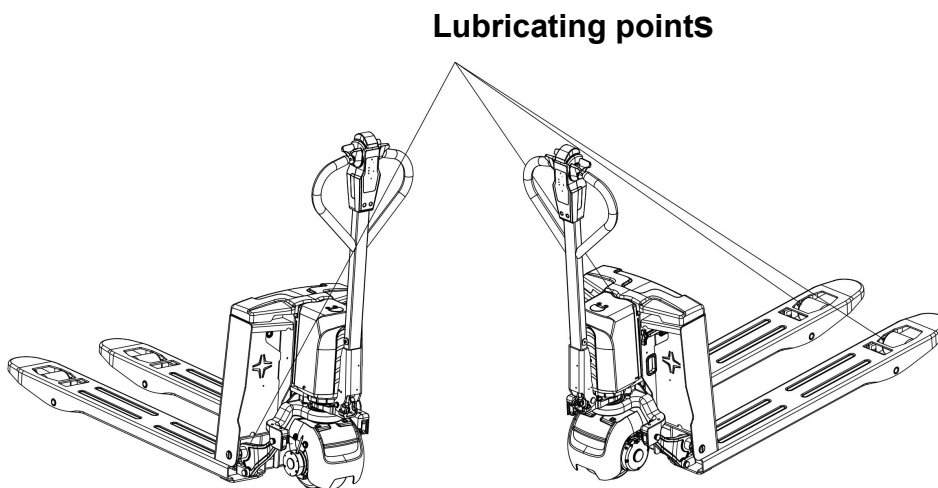

Fig. 13: Lubricating points

c. Check and refill hydraulic oil

It is recommended to use hydraulic oil in accordance with average temperature:

Environment temperature	-5°C~25°C	>25°C
Type	HVLP 32, DIN 51524	HLP 46, DIN 51524
Viscosity	28.8-35.2	41.4 - 47
Amount	0.4 L	

Waste material like oil, used batteries or other must be properly disposed and recycled according to the national regulations and if necessary brought to a recycling company.

The oil level in the oil tank should be between min and max marks with fully lowered forks.

If necessary add oil at the filling point.

d. Checking electrical fuses

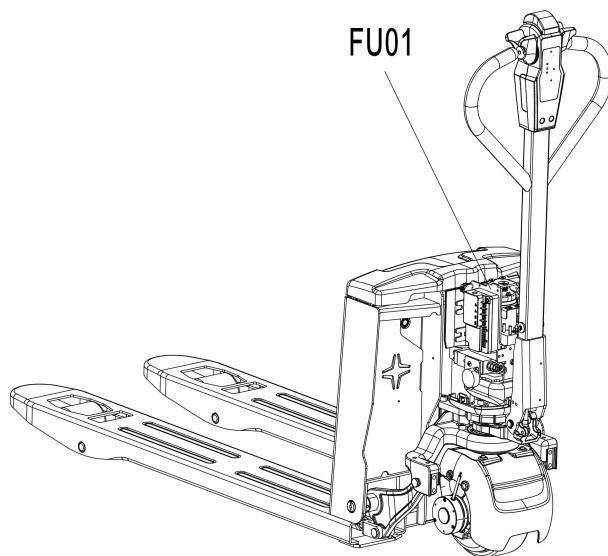

Fig. 14 Location of fuses for PWB-150

Table 7: Fuse

	Specification
FU 01	10A

8. TROUBLE SHOOTING



- IF TRUCK HAS MALFUNCTIONS, FOLLOW THE INSTRUCTIONS IN CHAPTER 6.

Table 8: Trouble shooting

TROUBLE	CAUSE	REPAIR
Load can't be lifted	Load weight too high	Lift only the max. capacity, mentioned on the ID-plate
	Battery low power	Charge the battery
	Lifting contactor failure	Check and contact with service support for replacement if necessary
	Hydraulic oil level too low	Check and eventually refill hydraulic oil
	Oil leakage	Repair the sealing of the cylinder
Oil leakage from air breathing	Excessive quantity of oil.	Reduce oil quantity.
Truck not starts operating	Battery is charging	Charge the battery completely and then remove the main power plug from the electrical socket.
	Battery not connected	Connect the battery correctly
	Fuse faulty	Check and eventually replace fuses
	Low battery	Charge the battery
	Emergency switch is activated	Turn the emergency switch clockwise
	Tiller in the operating zone	Move the tiller firstly to the braking zone.

If the truck has malfunctions and can't be operated out of the working zone, jack the truck up and go with a load handler under the truck and safe the truck securely. Then move truck out of the aisle.

9. WIRING/ CIRCUIT DIAGRAM

a. Electrical circuit diagram

PWB-150

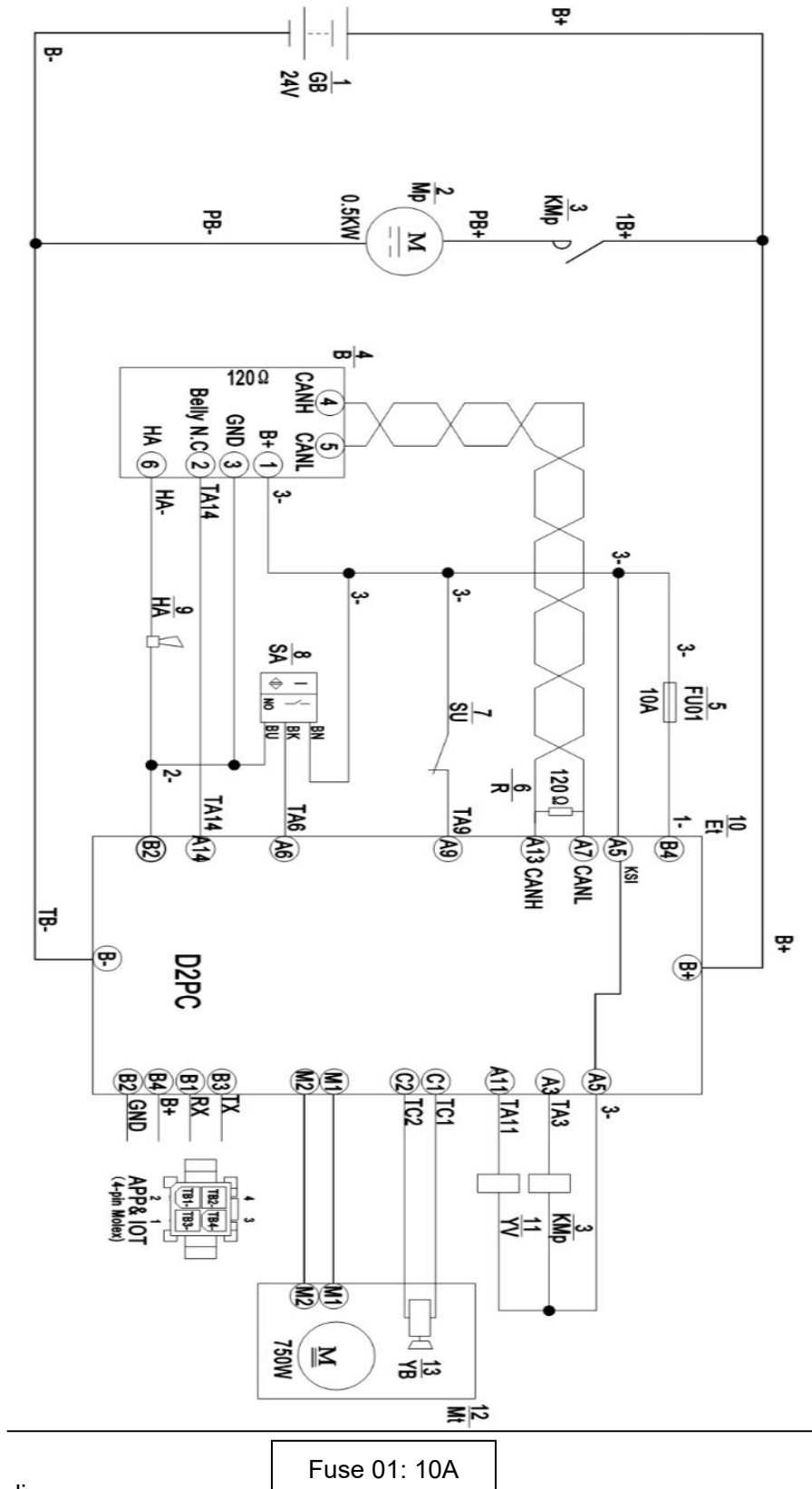

Fig.15: Electric diagram

Table 9: Description of electrical diagram

Code	Item	Code	Item
GB	Battery	SA	Proximity switch
Mp	Pump motor	HA	Buzzer
KMp	Pump contactor	Et	Controller
B	CAN tiller	YV	Electromagnetic valve
FU01	10A fuse	Mt	Traction motor
R	CAN terminal resistance	YB	Electromagnetic brake
SU	Limit microswitch		

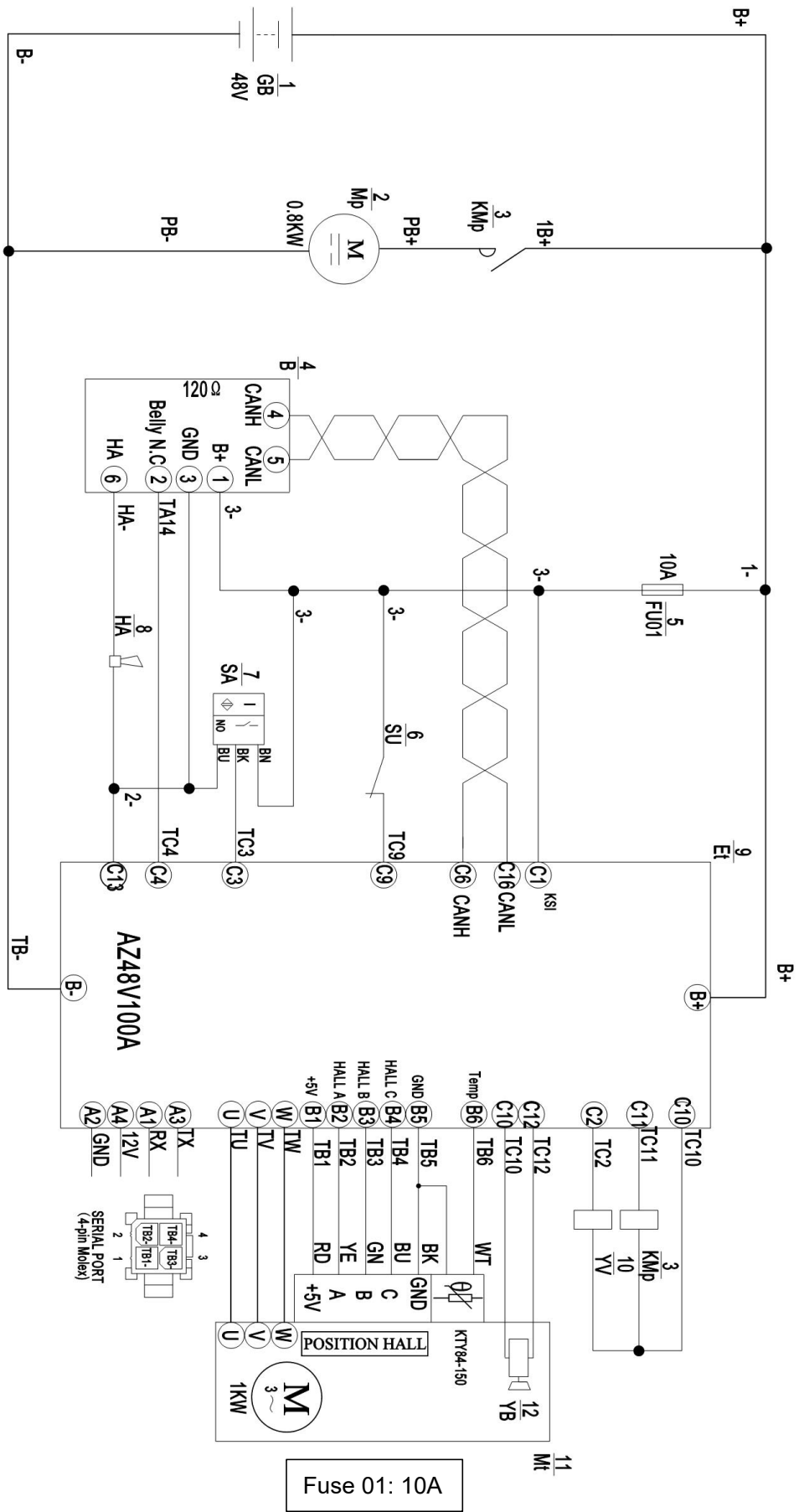

Fig.16: Electric diagram

Table 10: Description of electrical diagram

Code	Item	Code	Item
GB	Battery	SA	Proximity switch
Mp	Pump motor	HA	Buzzer
KMp	Pump contactor	Et	Controller
B	CAN tiller	YV	Electromagnetic valve
FU01	10A fuse	Mt	Traction motor
SU	Limit microswitch	YB	Electromagnetic brake

b. Hydraulic circuit diagram

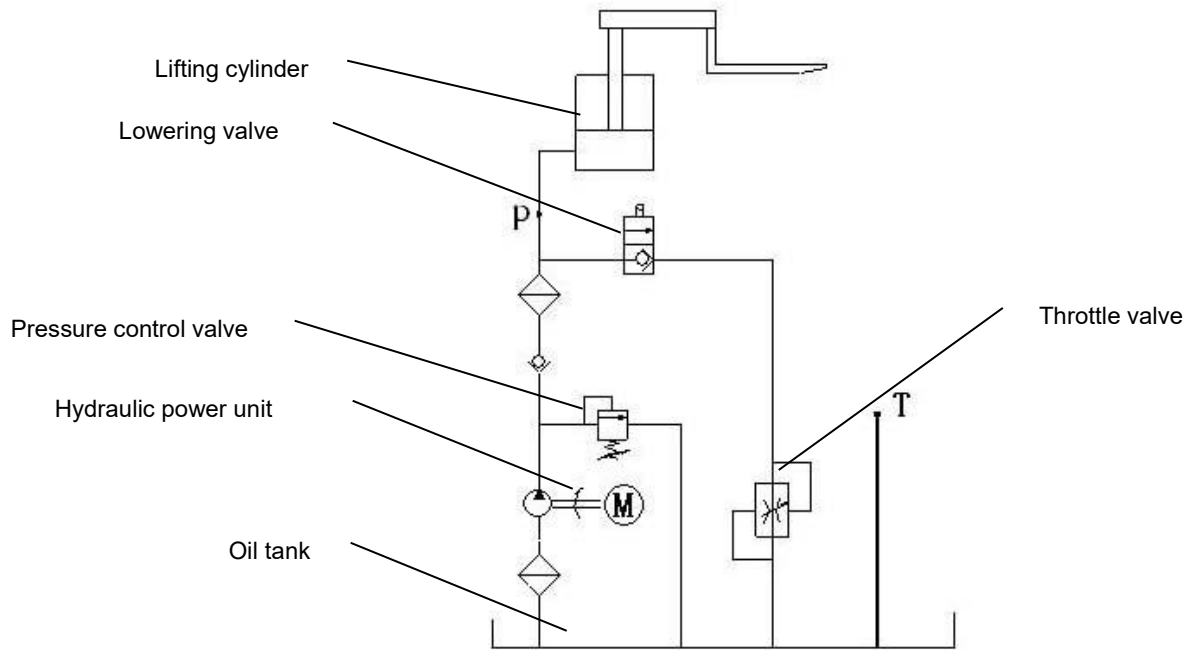

Fig. 17: Hydraulic circuit