

NOBLELIFT

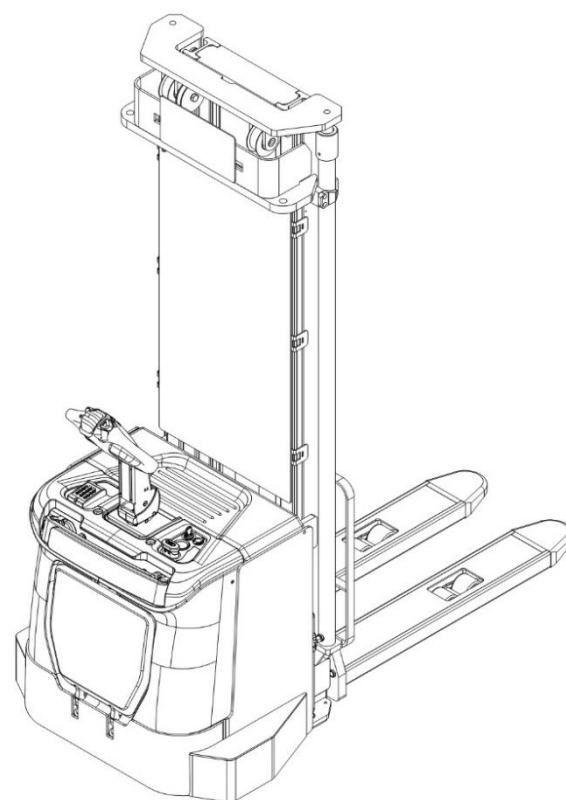

INSTRUCTION HANDBOOK PSN Series Electric Stackers (PS 16NW, PS 20NW)



WARNING

Do not use the electric stacker before reading and understanding these operating instructions.

NOTE:

- Please check the designation of your present type at the last page of this manual as well as on the ID-plate.
- Keep this manual for future reference.

This stacker can only be used in factories, tourist attractions and amusement places.

Version 02/2024

PS 16/20NW-SMS-007-EN

FOREWARD

Before operating the electric stacker, read this ORIGINAL INSTRUCTION HANDBOOK carefully and understand the usage of the stacker completely. Improper operation of the stacker may cause danger.

This handbook describes the usage of different electric stackers. When operating and servicing the stacker, make sure, that it applies to your type.

Keep this handbook for future reference. If this handbook or the warning/caution labels are damaged or lost, please contact your local dealer for replacement.

ATTENTION:

- Environmentally hazardous waste, such as batteries, oil and electronics, will have a negative effect on the environment or health, if handled incorrectly.
- The waste packages should be sorted and put into solid dustbins according to the materials and be collected disposal by local special environment protection bureau. To avoid pollution, it's forbidden to throw away the wastes randomly.
- To avoid leaking during the use of the products, the user should prepare some absorbable materials (scraps of wooden or dry duster cloth) to absorb the leaking oil in time. To avoid second pollution to the environment, the used absorbable materials should be handed in to special departments in terms of local authorities.
- Our products are subject to ongoing developments. The information written in this handbook is provided as reference for operating and servicing the stacker and may vary in terms of description of particular features of the truck.



NOTE: On this manual, the left sign indicates warning and danger, which can lead to death or serious injury if not followed.

Copyright

The copyright remains with the company, mentioned on the CE- certificate at the end of this document.

TABLE OF CONTENTS

CORRECT APPLICATION.....	1
2. DESCRIPTION OF THE STACKER	2
a. Overview of the main components.....	2
b. Main technical data.....	3
c. Description of the safety devices and warning labels (Europe and other, except USA)	6
d. Identification plate.....	6
3. WARNINGS, RESIDUAL RISK AND SAFETY INSTRUCTIONS.....	7
4. COMMISSIONING, TRANSPORTING, DECOMMISSIONING.....	9
a. Commissioning.....	9
b. Hoisting/ transportation.....	9
c. Decommissioning.....	10
5. DAILY INSPECTION	10
6. OPERATING INSTRUCTIONS.....	10
a. Parking.....	11
b. Residual lift diagram.....	11
c. Lifting.....	11
d. Lowering.....	11
e. Travelling.....	12
f. Steering.....	12
g. Braking.....	13
h. Malfunctions.....	13
i. Emergency.....	13
j. Pressure on drive wheel.....	13
7. PIN-CODE PANEL.....	14
a. Introduction.....	14
b. Main parameters.....	14
c. Main functions.....	14
d. Operation.....	14
e. Pin-code panel indicators.....	15
8. BATTERY SAFETY, CHARGING AND REPLACEMENT.....	16
a.Replacement.....	16
b.Charging the battery.....	27
c.Battery replacement.....	33
9. AQUAMATIC SYSTEM (OPTIONAL)	34
a. Replenish water after charging.....	34
b. Water replenishment interval.....	34
c. Operation.....	34
10. REGULAR MAINTENANCE	36
a. Maintenance checklist.....	36
b. Lubrication points.....	37
c. Check and refill hydraulic oil	37

d. Checking electrical fuses.....	38
e. Removing and reattaching the protection screen.....	39
11. TROUBLE SHOOTING.....	39
12. WIRING/ CIRCUIT DIAGRAM.....	41
a. Electrical diagram	41
b. Hydraulic diagram.....	53
13. DECLARATION OF CONFORMITY (valid, if sold within the EU).....	54

CORRECT APPLICATION

It is only allowed to use this electric stacker according to this instruction handbook.

The stackers described in this handbook are self-propelled pedestrian controlled electric powered stackers, with electrically powered lifting function. The stackers are designed for stacking operations in dedicated racking by lifting and lowering the palletized loads up to the desired lifting height.

Improper use can cause personal injury or damage to the machine.

The operator/operating company needs to ensure the correct use, and at the same time ensure that the stacker is only operated by personnel who have been trained and authorized to use the stacker.

This stacker needs to be used on a firm, flat, intact and proper surface. This stacker is designed for indoor applications with ambient environment from +5°C to +40°C (41°F to 104°F).

It is used under light load conditions without crossing permanent obstacles or potholes. The goods must be placed approximately at the load center of the stacker during operation.

It is strictly forbidden to lift or carry personnel. If carried, the goods must be lowered to the lifting point.

It is not allowed to use this stacker on tail lifts or loading ramps.

The capacity is marked on the load diagram as well on the identification plate. The operator has to consider the warnings and safety instructions.

The operating lighting must be at least 50 lux.

Modification

Any modifications or changes that may affect the rated capacity, stability or safe operation of the stacker must be approved in advance in writing by the original manufacturer or its authorized representative or its successor. This includes the effects of changes, such as: braking, steering, visibility and the increase in movable accessories.

After the manufacturer or its successor has approved the modifications or changes, the capacity plate, labels, identification mark, operation and maintenance manual must be changed accordingly.

Damage to the stacker caused by not following these instructions will make the warranty invalid.

2. DESCRIPTION OF THE STACKER

a. Overview of the main components

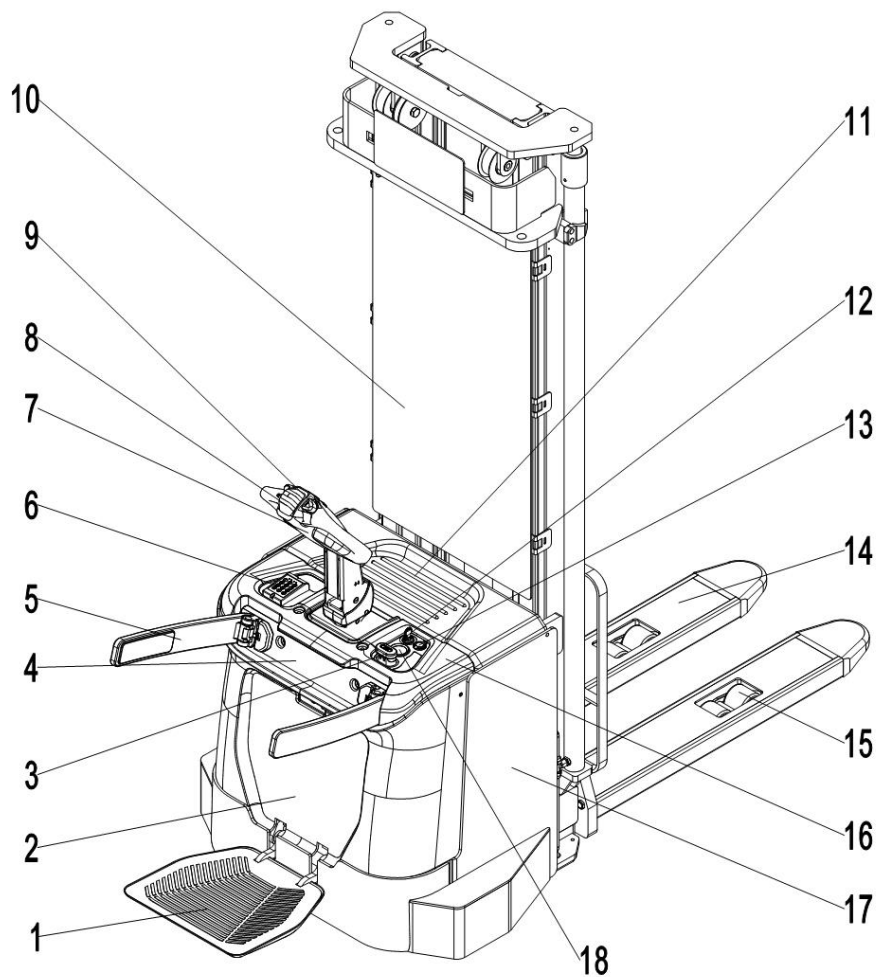

Fig. 1: Overview of the main components

- | | |
|--------------------------------|-------------------|
| 1. Platform | 10. Mast |
| 2. Main cover | 11. Battery panel |
| 3. Emergency stop | 12. Key switch |
| 4. Protection arm cover | 13. USB interface |
| 5. Protection arm | 14. Fork |
| 6. Pin code | 15. Load roller |
| 7. Tiller | 16. Top cover |
| 8. Safety button/ Belly button | 17. Chassis |
| 9. Accelerator | 18. Display |

b. Main technical data

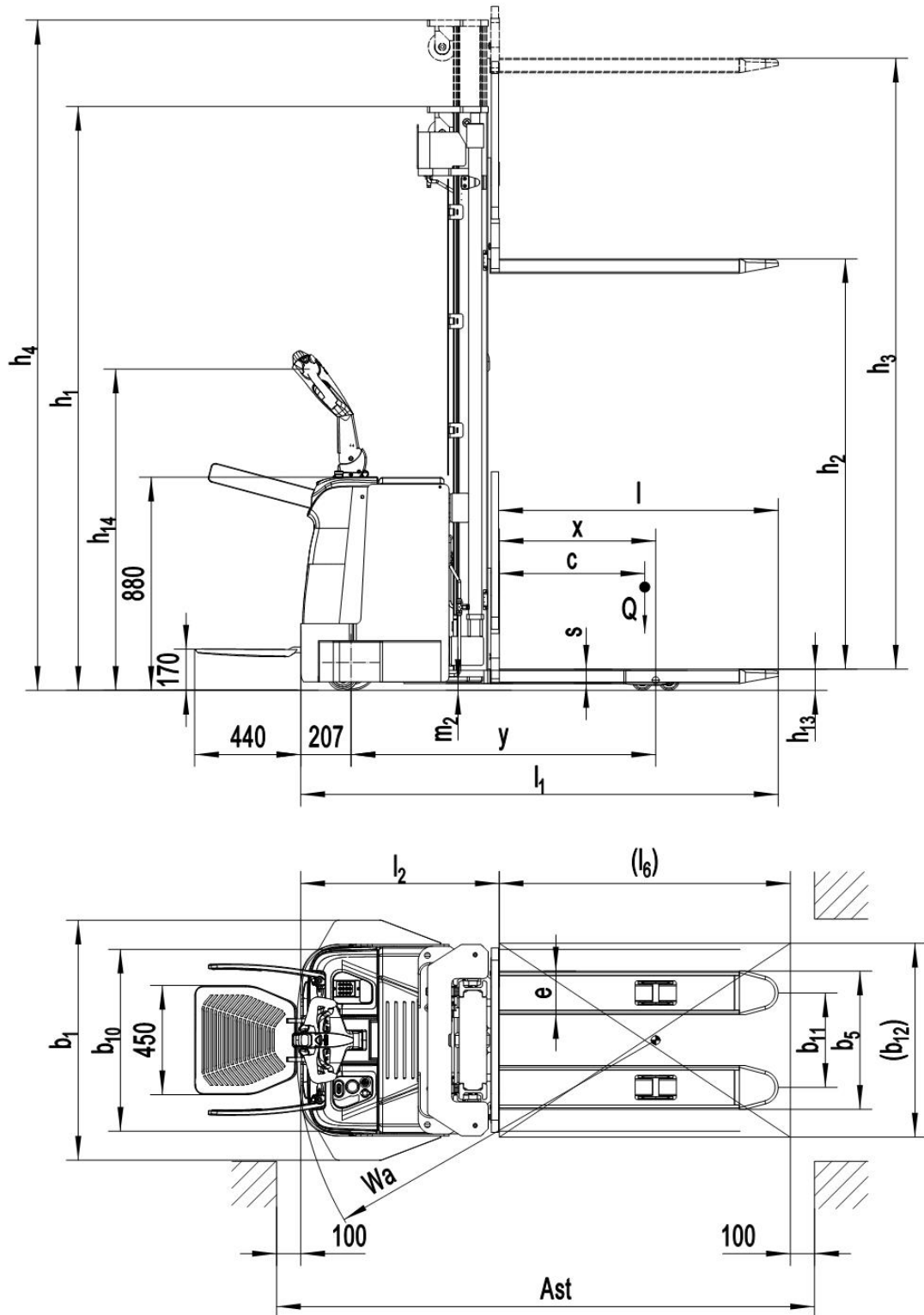

Fig. 2: Technical data

Table1: Main technical data for standard version

Type sheet for industrial stacker acc. to VDI 2198					
Distinguishing mark	1.2	Manufacturer's type designation		PS16NW(5500)	PS20NW(4600)
	1.3	Drive: electric (battery type, mains, ...), diesel, petrol,		Battery	
	1.4	Operator type: hand, pedestrian, standing, seated,		Pedestrian	
	1.5	Rated capacity/ rated load	Q (t)	1.6	2.0
	1.6	Load centre distance	c (mm)	600	
	1.8	Load distance, centre of drive axle to fork	x (mm)	647	650
	1.9	Wheelbase	y (mm)	1256	1392
Weight	2.1	Service weight	kg	1365	1630
	2.2	Axle loading, laden front/ rear	kg	1000/1965	1124/2506
	2.3	Axle loading, unladen front/ rear	kg	943/422	1067/563
Tyres	3.1	Tires		Polyurethane wheels	
	3.2	Tire size, front	Ø x w (mm)	Ø230x70	
	3.3	Tire size, rear	Ø x w (mm)	Ø84x70	
	3.4	Additional wheels (dimensions)	Ø x w (mm)	Ø124x60	
	3.5	Wheels, number front/ rear(x=driven wheels)		1x+2/4	
	3.6	Tread, front	b ₁₀ (mm)	750	
	3.7	Tread, rear	b ₁₁ (mm)	390/505	
Dimensions	4.2	Height, mast lowered	h ₁ (mm)	2410	2228
	4.3	Free lift	h ₂ (mm)	1820	1520
	4.4	Lift	h ₃ (mm)	5410	4510
	4.5	Height, mast extended	h ₄ (mm)	5980	5200
	4.9	Height drawbar in driving position min./ max.	h ₁₄ (mm)	950/1350	
	4.15	Height, lowered	h ₁₃ (mm)	90	
	4.19	Overall length	l ₁ (mm)	1968 ¹⁾	2101 ¹⁾
	4.20	Length to face of forks	l ₂ (mm)	818 ¹⁾	951 ¹⁾
	4.21	Overall width	b ₁ (mm)	990	
	4.22	Fork dimensions DIN ISO 2331	s/e/ l (mm)	60/180/1150	
	4.25	Fork spread	b ₅ (mm)	570/685	
	4.32	Ground clearance, centre of wheelbase	m ₂ (mm)	28	28
	4.33	Aisle width for pallets 1000x1200 crossways	A _{st} (mm)	2396 ¹⁾	2530 ¹⁾
	4.34	Aisle width for pallets 800x1200 lengthways	A _{st} (mm)	2382 ¹⁾	2516 ¹⁾
	4.35	Turning radius	W _a (mm)	1500 ¹⁾	1634 ¹⁾
Performance	5.1	Travel speed, laden/ unladen	km/h	7.0/8.0	6.0/7.0
	5.2	Lift speed, laden/ unladen	m/s	0.09/0.14	0.09/0.14
	5.3	Lowering speed, laden/ unladen	m/s	0.25/0.20	0.25/0.20
	5.8	Max. gradeability, laden/ unladen	%	6/12	6/12

	5.10	Service brake		Electromagnetic Braking	
Electric-engine	6.1	Drive motor rating S2 60min	kW	1.4	1.4
	6.2	Lift motor rating at S3 10%	kW	3.0	3.0
	6.3	Battery acc. to DIN 43531/35/36 A, B, C, no		3VBS	3PZS
	6.4	Battery voltage/ nominal capacity K ₅	V/Ah	24/270	24/350
	6.5	Battery weight	kg	230	288
	6.6	Energy consumption acc. to DIN EN 16796	kWh/h	0.94	1.32
Additional data	8.1	Type of drive unit		AC	
	8.4	Sound pressure level at driver's seat	dB (A)	<70	

1) For stacker with platform extended, +440mm

Type	Height, mast lowered h1 (mm)	Free lift h2 (mm)	Lift h3 (mm)	Height, mast extended h4 (mm)
PSN Series (PS16NW)				
Two stage mast	1958	—	2810	3380
	2108	—	3110	3680
	2308	—	3510	4080
Two stage mast FFL (Full-Free-Lift)	1958	1410	2810	3380
	2108	1560	3110	3680
	2308	1760	3510	4080
Three stage mast	2008	—	4210	4780
	2108	—	4510	5080
Three stage mast FFL (Full-Free-Lift)	1708	1120	3310	3880
	1908	1320	3910	4480
	2008	1420	4210	4780
	2108	1520	4510	5080
	2343	1756	5210	5780
	2410	1820	5410	5980
PSN Series (PS20NW)				
Two stage mast	2078	—	2810	3500
	2228	—	3110	3800
	2428	—	3510	4200
Two stage mast FFL (Full-Free-Lift)	1978	1310	2610	3300
	2078	1410	2810	3500
	2228	1560	3110	3800
	2428	1760	3510	4200
Three stage mast	2128	—	4210	4900
	2228	—	4510	5200
Three stage mast FFL (Full-Free-Lift)	1978	1310	3910	4600
	2128	1420	4210	4900
	2228	1520	4510	5200

c. Description of the safety devices and warning labels (Europe and other, except USA)

The description of the safety and warning labels for USA market is indicated in chapter 11.

- A Crane hook decal
- B Warning labels: Do not step under or on the forks
- C Residual capacity label
- D No passengers label
- E Identification plate (ID-plate)
- F Sticker to observe and follow these instructions
- G Warning sticker
- H Indicating decal

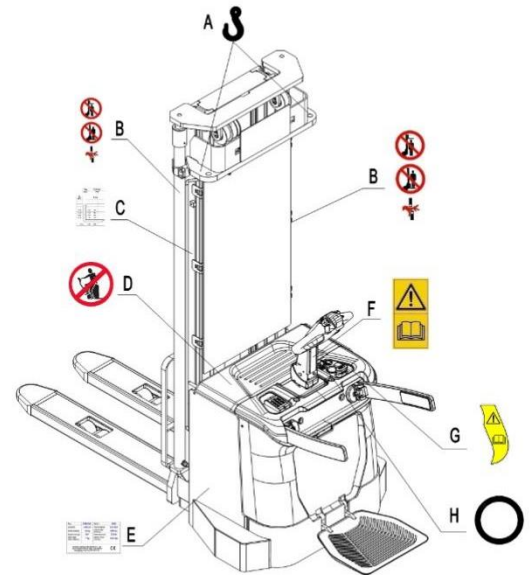

Fig.3: Safety and warning labels

The stacker has an emergency button (18) which stops all lifting-, lowering-, driving- functions and engages the fail-safe electromagnetic brake when it is pressed. By pulling this button, the stacker can be operated after the controller checked the functions. Before operating, insert the key and turn the switch (16) clockwise or, in case the stacker is equipped with pin-code panel, press the start button and enter the pin-code passwords or use RFID access card to activate the stacker.

To prevent unauthorized access, turn the key anti-clockwise and remove it if you do not operate this stacker or, in case the stacker is equipped with pin-code panel, press the start-button or press "X" button of pin-code panel. The stacker is equipped with a safety (belly) button (7) which switches the stacker driving away from the operator, if the stacker travels towards the operator and the tiller is in its operating zone. Follow the instructions given above. Replace the labels and decals if they are damaged or missed.

d. Identification plate

Pallet Stacker			
Special Equipment Manufacturing License No. :			
Type	xxxx	Rated capacity	xxxx kg
Rated voltage	xx V	Service weight without battery	xxxx kg
Battery weight maximum	xxx kg	Battery weight minimum	xxx kg
Net weight (without load and battery)	xxx kg	Lift height maximum	xxxx mm
Serial number	xxxxxxxxxx	Equipment code	xxxxxxxxxx
Manufacturer Name XXXXXXXXXXXXXXXXXXXX			
Manufacturer Address XXXXXXXXXXXXXXXXXXXX			

Fig. 4: Identification plate

3. WARNINGS, RESIDUAL RISK AND

SAFETY INSTRUCTIONS

DO NOT

- Stack a lifted load higher than the lifting point when driving outdoors.
- Put feet or hands under or into the lifting mechanism.
- Allow other person than the operator to stand in front of or behind the stacker when it is moving or lifting/lowering.
- Overload the stacker.
- Put foot in front of the wheels, which may cause injury.
- Lift people. People could fall down and suffer severe injury.
- Push or pull loads.
- Use the stacker without a protection screen.
- Place the load at the side or end of forks. Load must be distributed evenly on the forks.
- Use the stacker to load unstable or unbalanced goods.
- Use the stacker without the written consent of the manufacturer.
- Supply on board charger with AC voltage other than 100V or 240V.

Observe different ground conditions while driving, the load may fall or the stacker may lose control. Please check the condition of the load from time to time. Immediately stop operating the stacker if load becomes unstable. When the load slides on/off the stacker, immediately brake the stacker and press the emergency button (18). If the stacker has any malfunctions, follow the instructions of chapter 10.

Perform maintenance work based on regular inspections. This stacker is not waterproof, please use it under dry condition. Prolonged continuous operation may damage the power pack. Stop operation when the hydraulic oil temperature is too high.



- When operating this stacker, the operator has to wear safety shoes.
- This stacker is suitable for indoor applications with ambient temperature between +5°C (41°F) and +40°C (104°F).
- Operation lighting must be minimum 50 Lux.
- It is not allowed to operate the stacker on ramps.
- In order to prevent accidental movements when not operating the stacker (i.e. caused by another person, etc.), turn off the power of the stacker and remove the key.
- Lifted loads could become unstable at wind forces and influence the stability. Do not lift loads in windy conditions.
- Lifted loads will affect the field of view, adopt all necessary safety measures, and use auxiliary tools to ensure the view if necessary.
- Avoid collision of the foldable platform against surrounding objects, especially when driving forward, there is a risk of collision and shearing. Always maintain a safe

operating speed according to different environments.

4. COMMISSIONING, TRANSPORTING, DECOMMISSIONING

a. Commissioning

Table 2: Commissioning data

Type	PS16NW/5500	PS20NW/4600
Commissioning weight [kg]	1385	1650
Lift [mm]	5500	4600

After receiving our new stacker or when re-commissioning is required, please perform the following steps before operating the stacker (for the first time):

- Check if all parts are included and not damaged.
- Install and charge the battery (see chapter 8).
- Carry out daily inspections and machine function inspections.

For transporting, remove the load, lower the forks to the lowest position and fix the stacker safe with dedicated hoisting equipment according to Fig. 5.

b. Hoisting/ transportation

Hoisting



**USE DEDICATED CRANE AND HOISTING EQUIPMENT.
DO NOT STAND UNDER THE SWAYING LOAD.
DO NOT WALK INTO THE HAZARDOUS AREA DURING HOISTING.**

Park the stacker safely and fasten it according to the points shown in Figure 5.

Hoist the stacker and move it to the destination, and place the stacker safely and remove the hosting equipment .

Refer to Figure 6 for the fixing points for dedicated lashing belts.

Transportation



DURING TRANSPORTATION ON A LORRY OR stacker, ALWAYS FASTEN THE STACKER SECURELY.

Lower the forks and park the stacker securely.

Fasten the stacker by dedicated lashing belts according to fig. 6 and fasten the other side at the transporting vehicle.

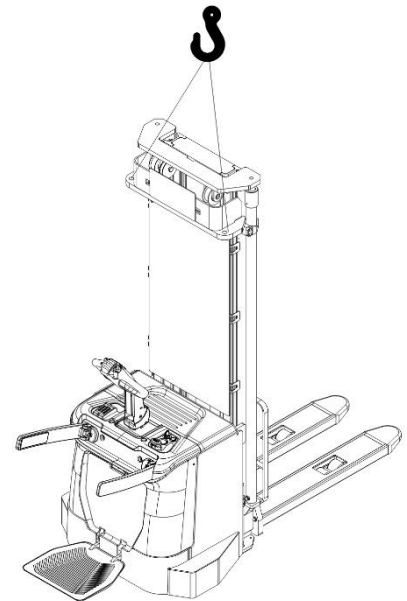

Fig.5: Lifting with a crane

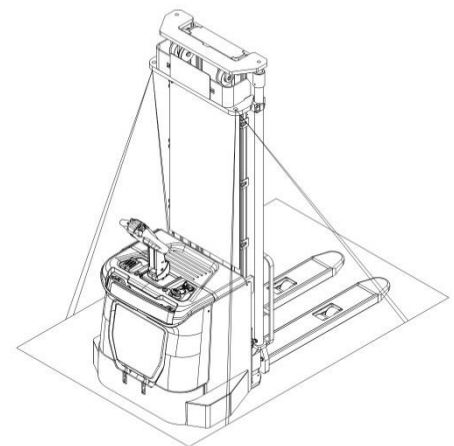

Fig. 6: Fixing points

c. Decommissioning

Remove the load and lower the forks to the lowest position for storage. Apply grease to all lubrication points mentioned in this manual (regular inspection) to prevent rust, corrosion and dust on the stacker. Remove the batteries and jack the stacker safely, so that there will be no flattening of wheels after storage. For final decommissioning hand the stacker to a designated recycling company. Oil, batteries and electric components must be recycled according to regulations.

5. DAILY INSPECTION

This chapter describes the pre-shift inspections required before operating the stacker.

Daily inspections can effectively find faults or malfunctions in this stacker. The following points of the stacker should be checked before operation.



**MOVE THE LOAD AWAY FROM THE STACKER AND LOWER THE FORKS.
DO NOT USE THE STACKER IF YOU FIND ANY MALFUNCTIONS.**

- Check for scratches, deformation or cracks.
- Check if there is any leaks of hydraulic cylinder.
- Check the longitudinal driving condition of the stacker.
- Check the chain and rollers for damages or corrosion.
- Check whether the wheels can move smoothly.
- Press the emergency button to check the condition of emergency brake.
- Check the lifting/lowering function by operating the button.
- Check whether the protection screen is damaged and whether it is assembled correctly.
- Check the buzzer.
- Check whether all bolts and nuts are tightened.
- Check the condition of the key switch.
- Check the speed limit switch.
- Visually check for any damaged hoses or wires.
- If the stacker is equipped with a load backrest, check whether it is damaged and whether it is assembled correctly.

6. OPERATING INSTRUCTIONS



**BEFORE OPERATING THIS STACKER, PLEASE FOLLOW THE WARNINGS AND SAFETY INSTRUCTIONS (SEE CHAPTER 3).
BEFORE OPERATING THIS STACKER, ENSURE THAT THE LOAD OR OTHER EQUIPMENT WILL NOT CAUSE INSUFFICIENT VISIBILITY!**

Make sure that the load is palletized horizontally and stably, and that the daily inspection is carried out. For starting, insert

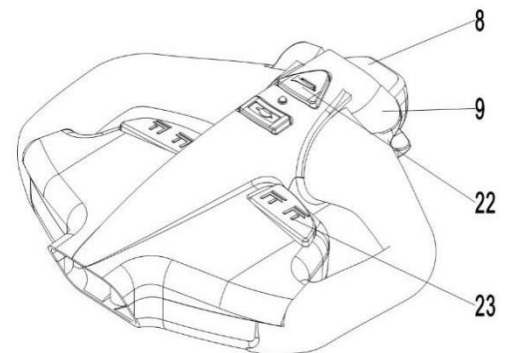

Fig.7: Control handle

the key and turn it clockwise to “ON” position. Eventually before activating the key switch (12), the emergency button (3) must be pulled carefully.

Press the horn button (22) to activate the audible warning signal.

a. Parking



DO NOT PARK THE STACKER ON INCLINED SURFACES.

The stacker is equipped with an electromagnetic fail-safe stopping and parking brake.

Always lower the forks fully and drive the stacker to a safe area. Turn the key anti-clockwise to “OFF” position and remove the key.

b. Residual lift diagram

The residual lift diagram indicates the maximum capacity Q [kg] for a given load centre c [mm] and the corresponding lift height H [mm] for the stacker with horizontal load. The white mark on the mast indicates the reachable lifting height. For instance, the stacker with a load centre of gravity distance c of 600 mm and a maximum lift height H of 5500 mm, its max. capacity Q is 600 kg.

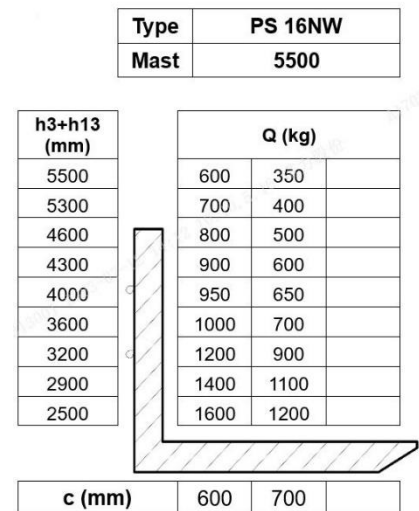

Fig. 8: Residual lift diagram

c. Lifting



CAPACITY IS 1600/2000 kg WHEN THE LOAD CENTER IS 600MM.

LIFT ONLY CAPACITIES ACCORDING TO THE RESIDUAL LIFT DIAGRAM.

Travel with the fully lowered forks and press the lifting button (Fig. 7, 23) until the forks reach your desired lifting height.

In case the protection arms are open, the maximum lifting height is 1800 mm. If you want to lift forks higher, please retract the protection arms.

d. Lowering

If the forks are in the racking, firstly move the stacker out of the racking carefully with/without pallet, take care that the forks will not touch the racking.

Press the lowering button (Fig. 7, 23) carefully.

Lower the load until the forks are clear of the pallet, then drive the stacker carefully away from the load.

TRAVEL ON INCLINES ONLY WITH THE LOAD FACING UPHILL(fig.9).
DO NOT TRAVEL ON INCLINES MORE THAN SPECIFIED WITH THE TECHNICAL DATA.
TRAVELLING IS ONLY ALLOWED IF THE FORKS ARE LOWERED DOWN TO THE LIFTING POINT (<300MM).

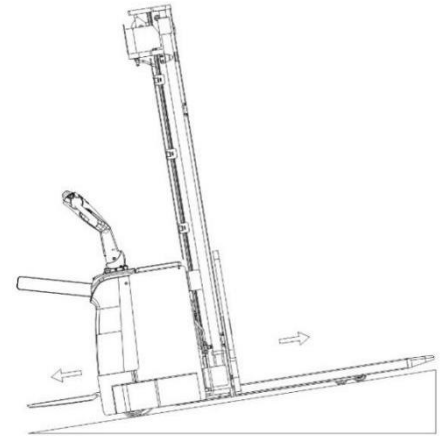

Fig.9: Load facing uphill

e. Travelling

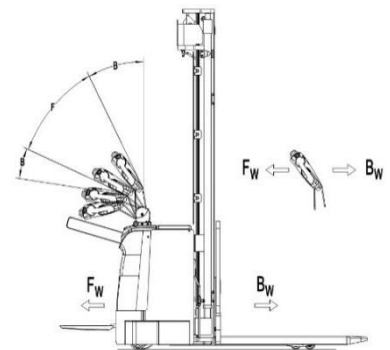

Fig.10: Operating direction

Start the stacker by turning the inserted key to “ON” position or by activation from Pin-code panel, then carefully pull up the emergency button. Move the tiller to the operating zone ('F', fig.10).

Turn the accelerator to the desired direction forward 'Fw.' Or backwards 'Bw.'(fig. 10).

Control the travelling speed by moving the accelerator (9) carefully until you reach the desired speed. **THE STACKER EQUIPS WITH A FOLDABLE PLATFORM AND PROTECTION ARMS. NOTE THAT THE WORKING MECHANISM OF PLATFORM AND PROTECTION ARMS DIFFER ON MODES. BACK TO THE NEUTRAL POSITION OF STEERING WHEEL.**

If you move the accelerator back to the neutral position, the stacker will decelerates the stacker until the stacker stops, and the parking brake will be engaged. In addition to the pedestrian mode, the stacker can also be operated in the following modes: Carefully drive the stacker to the destination. Observe the floor conditions

and adjust the travelling speed through the accelerator.

- With unfolded platform (1) and protection arms (5) in activated position, operate the stacker travelling at maximum speed.

- With unfolded platform (1) and protection arms (5) retracted, reduce the speed to be less than 6km/h. Travelling speed of the stacker depends on the the controllers parameter settings.
- With platform (1) folded and protection arms (5) retracted, reduce the speed to be less than 6km/h. Travelling speed of the stacker depends on the the controllers parameter settings.

f. Steering



The stacker can be equipped with Electric Power Steering (EPS) system. Be careful when operating the stacker with EPS system, as it is different to operate the stacker with EPS system and the stacker without EPS system.

Steer the stacker by moving the tiller to the left or right.

g. Braking



THE BRAKING PERFORMANCE DEPENDS ON THE FLOOR CONDITIONS AND THE LOAD CONDITIONS OF THE STACKER.

The braking function can be activated in the following ways:

- By moving the accelerator (9) to '0' position or releasing the accelerator, the regenerative braking is activated and the stacker brakes until it stops.
- By directly moving the accelerator (9) from one driving direction to the opposite direction, the stacker regeneratively brakes until it starts travelling into the opposite direction.
- The stacker brakes when the tiller is operated up and down to the braking area ('B'). When the tiller is released, it will automatically move to the upper braking zone ('B'). And the stacker will brake until it stops.
- The safety (belly) button (8) prevents the operator from being crushed. If this button is activated, the stacker will slow down and/or start driving a certain distance backwards ('Bw.') and stop. If the tiller is in operating area and the stacker does not move, please consider that this button still works in this situation.

h. Malfunctions

If there is any malfunction or the stacker is inoperable, please stop using the stacker and press the emergency button (18). If possible, please park the stacker in a safe area, turn the key counterclockwise and remove the key from the key switch (16). If it is a stacker with optional pin-code panel, please press the start button or press "X" button on the pin-code panel. Notify the manager immediately or contact your after-sales service personnel. If necessary, use dedicated towing/lifting equipment to move the stacker out of the operating area.

i. Emergency

In an emergency or when the stacker turns over, keep a safe distance. If possible, press the emergency button (18), and all electrical functions will be stopped.

j. Pressure on drive wheel



The stacker is equipped with a drive wheel pressure adjustment mechanism, and only the after-sales personnel of the company or the authorized personnel of the company are allowed to perform related operations. Otherwise, it may cause malfunctions to the stacker or injury to personnel.

7. PIN-CODE PANEL

The stacker can be equipped with an optional pin-code panel (5). Then a button (26) will replace the key switch (16) if the stacker is equipped with pin-code panel.

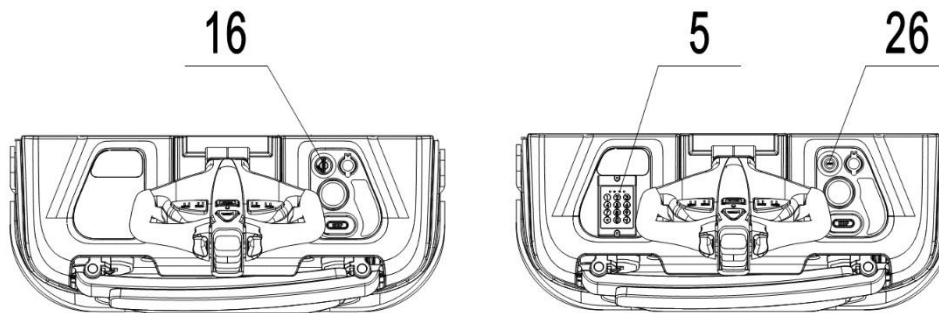

Fig.11: Pin-code panel

a. Introduction

The pin-code panel is an electronic system for access device. Before entering the authorized password, the stacker will not be allowed to start. The main function is to prevent unauthorized personnel from operating the stacker. In addition to being easy to use, this product is also a great help to the security of the stacker.

b. Main parameters

Working voltage: 12V-60V

Ambient temperature: -40°C to +90°C (-40°F to 194°F)

IP level: IP65

c. Main functions

This pin-code panel supports up to 5 ID cards and 1 set of input password. The password consists of four numbers (0-9).



Please check the administrator password on the product instruction manual. Default user password is "1234". Check the instruction manual for changing the password.

d. Operation

1. ID card Access

Place the ID card close to the pin-code panel, there will be a short beep if it is a valid ID card, then the blue indicator light will be on, which indicates the pin-code panel works normally. The red indicator light will flash when the card is invalid and the stacker can't be used.

2. Password Access

- Enter the password, press "✓" button. If the password is correct, the stacker can be operated.
- Press and release "×" button, and the stacker will shut down
- Enter the password again if you want to operate the stacker again.

e. Pin-code panel indicators

Red indicator --- Fault code

Yellow indicator --- Waiting for instructions

Blue indicator --- Active status

Green indicator --- Power on

8. BATTERY SAFETY, CHARGING AND REPLACEMENT

a.Replacement



- Only qualified personnel is allowed to service or charge the batteries. The instructions of this handbook and from the battery manufacturer must be observed.
- Lead-acid batteries and lithium batteries are allowed.
- Be aware about the risk of accumulation of hydrogen under battery cover, keep it opened during charging.
- Recycling of batteries undergoes with national regulations. Please follow these regulations.
- By handling batteries, open fire is prohibited, gases may cause explosion!
- In the area of battery charging neither burning materials nor burning liquids are allowed. Smoking is prohibited and the area must be ventilated.
- Park the truck securely before starting charging or installing/changing the batteries
- Before finishing the maintenance work, make sure, that all cables are connected correctly and not disturbed towards other components of the truck.



LEAD-ACID TRACTION BATTERIES WITH LIQUID ELECTROLYTE AND LITHIUM BATTERIES ARE ALLOWED. THE WEIGHT OF THE BATTERIES HAS AN INFLUENCE TO THE TRUCKS OPERATING BEHAVIOR. PLEASE CONSIDER THE MAXIMUM OPERATING TEMPERATURE OF THE BATTERIES.

Depending on the version, the truck is equipped with different battery types. The following table shows which combinations are intended as standard.

1.Description of the lithium-ion battery

The lithium-ion battery is a battery with rechargeable cells, the battery is designed for industrial trucks and can withstand related vibrations during operation. The battery is equipped with special connections for charging and discharging operations. Do not try to install or connect improper connectors to the battery.

The battery is equipped with BMS – battery management system, which performs the control of battery condition and implements related safety protocols to protect the battery and cells from damages caused by operation or environmental conditions. The BMS controls the following safety functions and conditions: voltage, temperature, undervoltage, overvoltage, overtemperature, overcurrent, short circuit, etc. The internal resistance of lithium battery is generally low, which minimizes heat generation and maximizes the available power of the truck.

Temperature range for using the battery is from +5°C to +40°C. Low temperatures reduce the effective battery capacity, high temperatures reduce the battery's life time. The temperature difference between the two sides of the battery shall not exceed 5°C.

Only approved battery chargers must be used to charge the lithium battery.

2.Lithium-ion battery Decals

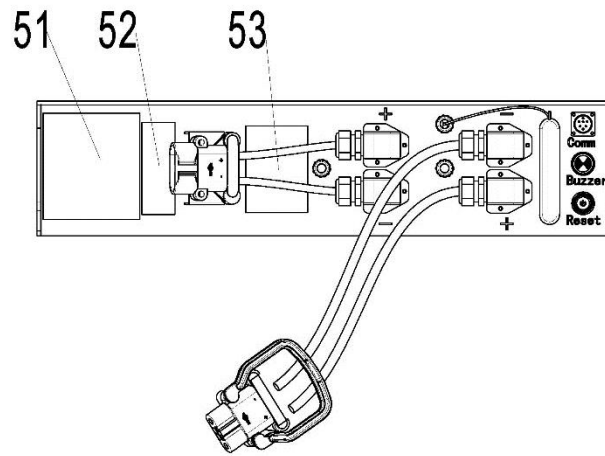

Fig. 12: Battery Decals

Table 3: Battery Decals

Item	Description
51	Identification plate
52	Bar code and two-dimensional code
53	Warning Label

Identification plate and Warning label

54	• LOGO	
55	• Model	xxx
56	• Nominal Voltage	xx V
57	• Rated Capacity	xx Ah
58	• Energy	xx kWh
59	• Weight	xx kg±xx kg
60	• HW REV	G-CH-FK-R
61	• TCP	xxx
62	• Serial No.	xxx
63	• Date of manufacture	20xx.*
64	• Manufacturer:	
65	• Address:	

Fig. 13: Identification plate

Table 4: Identification plate

Item	Description
54	Manufacturer trademark
55	Model designation
56	Rated voltage
57	Rated Capacity
58	Energy
59	Battery weight
60	Hardware revision
61	TCP
62	Serial No.
63	Production date
64	Battery manufacturer
65	Manufacturer's address

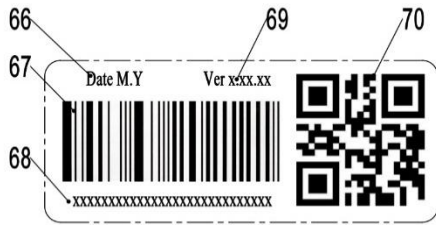

Fig. 14: Bar code and two-dimensional code

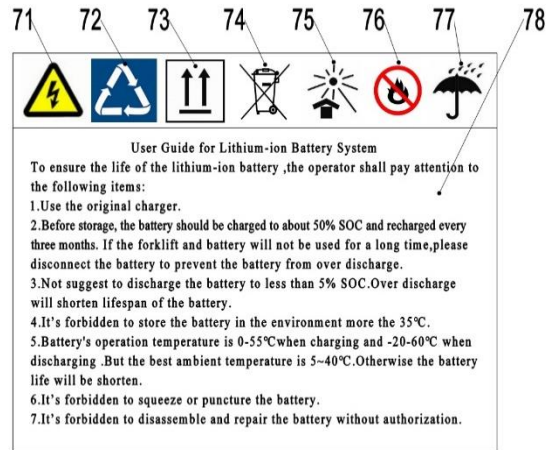

Fig. 15: Warning Label

Table 5: Bar code and two-dimensional code

Item	Description
66	Production date
67	Battery information bar code
68	Bar code interpretation
69	Software version of battery
70	Battery information 2D code

Table 6: Warning Label

Item	Description
71	Electrical hazard marker
72	Rechargeable logo
73	Vertical upward packing, transportation
74	No putting into ordinary garbage bins
75	No long-term exposure to sunshine
76	Stay away from fire
77	Keep out of the rain
78	Guide to use

3.Safety Instructions, Warning Indications and other Notes of Lithium-ion battery

Safety regulations for handling lithium-ion batteries

Do not try to make any repairs or servicing of lithium batteries. Replacement of parts is not assumed.



Risk of electric shock and burning

The battery's charging and discharging connectors have open terminals, avoid any body contacts, contamination or direct contacts with objects which can cause short circuit connection of terminals. Use necessary pre-cautions and protective caps to secure the open terminals. The connectors should be maintained in clean and dry conditions.



Use only batteries designed and approved by the manufacturer for the truck.

Do not try to modify or alter the battery.



Any damage or defects to the charger can result in accidents. Use only charger approved by the manufacturer of the truck, which is suitable for used battery

In case charger has any damages or defects, exclude the charger from operation and contact your service provider. Do not modify or try to repair the charger.



Improper use of charger or use of wrong charger can cause damages to a battery or charger. Follow the required charger specifications; If the operation voltage of the charger is out of the applicable voltage range, the charger or battery may be damaged causing serious safety risks. The charger in use must be approved by the battery (truck) manufacturer.

Reversed connection of charging plug is prohibited. Follow the instruction for correct connection. For disconnection of charging plug use dedicated grip and never pull out the plug by means of cable.

Stop charging immediately if any abnormalities are detected, e.g. severe temperature increase, deformation of battery case, smoke, noise etc.



Intermediate charging

Lithium batteries support so called opportunity charging. The lithium battery, which is not fully discharged can be charged in any time. However, frequent opportunity charging not to the full charging state and stop of charging process before the appearance of corresponding indication of charger may result in dis-balance voltage of cells which increases the battery BMS calculation error. In order to effectively deal with this phenomenon, charge the battery in full allowing the automotive balancing process to be completed at least

once a week.

Do not charge a fully charged battery



Note that in order to prevent the battery from continuing restart of charging under fully charged condition causing reduction of battery lifetime, the BMS has a protection function that prohibits recharging of fully charged battery. The charger will not work while battery is fully charged.

Potential hazards

If equipment is used according to its design purpose, following the correct operations procedures, there are no hazards anticipated.

The following hazards can arise in the event of improper use:

- Physical damage to the battery in case a battery falls or is deformed through impacts. Mechanical damages can cause leakages of harmful materials, fire or battery explosion.
- Short circuits may be caused by connecting the two battery terminals, for instance caused by water or intentional/unintentional connections.
- Temperature damages caused by placing of batteries in overheated environment conditions or being exposed to impact of fire, open sunlight etc. can cause leakages of harmful materials, fire or battery explosion.

In order to avoid fire, explosion and/or leakage of harmful materials, a safe place for storing non-functional or damaged batteries until the service arrives on site must satisfy the following criteria:

- Do not store in places where personnel is located.
- Do not store in places with valuable objects and close to valuable objects.
- A Class D fire extinguisher must be available on demand.
- There should not be any fire or smoke detectors in the storage area in order to ensure that an automatic fire detection system is only activated in the event of actual danger (e.g. flames).
- No ventilation intake pipes should be in the facility to exclude spreading of discharged content within a building.







Examples of where to store a non-functional battery:

- Roofed outdoor position.
- Ventilated container.

Covered fire resistant box with pressure and smoke discharge option.

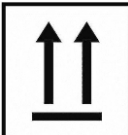
Symbols - Safety and Warnings

Table 7: Symbols - Safety and Warnings

	Caution! Battery short-circuit is prohibited.
	The battery can be recharged cyclically
	Vertical upward packing, transportation and use
	Used lithium-ion batteries must be treated as hazardous waste. Lithium-ion batteries marked with the recycling symbol and the sign showing a crossed-out waste bin must not be disposed of with ordinary household waste.
	Protect the lithium-ion battery from solar radiation or other forms of heat radiation. Do not expose the lithium-ion battery to heat sources.
	Avoid fire and short circuits causing overheating. Do not ignite or locate batteries close to open flame, heat sources or sparks. Keep lithium-ion batteries away from heat sources.
	The battery is not completely waterproof and should be avoided for a long time in the rain. If the battery is wet, wipe the dry connector in time.

Explosion and fire hazard



Physical damage, thermal effects or incorrect storage in the event of a defect can result in explosions or fire.
The battery materials can be flammable.

Particular hazard from combustion products

The lithium batteries may be damaged by a fire. When extinguishing a lithium battery fire, the following information must be taken into consideration.



Contact with combustion products can be hazardous

Fire produces combustion products, which can occur in the form of smoke, through leaking fluids, escaping gases, debris as well decomposition products of certain chemicals. These combustion

products are substances that enter the body through the respiratory tract and/or the skin can produce and adverse effects such as choking.



Avoid contact with combustion products.

Use protective equipment.

Special firefighting protective equipment

Use self-contained breathing apparatus.

Wear protective equipment.

Additional firefighting instructions

To prevent secondary fires, the lithium-ion battery must be cooled from the outside. Fluids or solids must never be directed into the lithium battery.

Suitable extinguishing agents

- Carbon dioxide extinguisher (CO₂)
- Water (not on mechanically opened or damaged batteries)

Unsuitable extinguishing agents

- Foam
- Grease fire extinguishing agents
- Powder extinguishers
- Metal fire extinguishers (PM 12i extinguishers)
- Metal fire powder PL-9/78 (DIN EN 3SP-44/95)
- Dry sand

Instructions for cooling an overheated, non-physically damaged battery

This type of damage may be caused by a short circuit inside the battery, which may result in leakage of harmful materials, fire or battery explosion.

Material discharge

Battery electrolyte fluid can be hazardous



Electrolyte fluid can be discharged if the battery is physically damaged. Avoid its contact with skin or eyes. If the contact happened:

- Rinse the affected parts with big amount of water and request for medical assistance immediately.
- In case of skin irritation or if any substances are breathed in request the medical assistance immediately.

Precautionary measures for personnel

- Keep personnel away, avoid any contact with smoke or discharged materials.

- Block off the affected area and ensure its reasonable ventilation.
- Wear personal protective equipment. If vapors, dust or aerosols are presented use self-contained breathing apparatus.

Precautionary measures for the environment

Do not allow spilled fluids to enter the water system, drainage system or the underground water.

Cleaning measures

The leaked fluid must be removed professionally following the related protocols.

Battery lifetime and maintenance

The lithium-ion batteries are maintenance-free.

Deep discharge can damage the battery

Self-discharge without periodical recharge can lead the battery to fully discharged state. Full discharge shortens the service life of the battery and can cause deep discharge and activation of related safety protocols when battery will not be able to be charged anymore.

Before a long period of inactivity, the battery must be charged to 40%~60%.

Control the level of battery charge at least every 12 weeks and re-charge if necessary.

The temperature range for storing of the battery should be within the range of 0°C to 30°C.

If the battery is deeply discharged or if the battery temperature is below the permissible level, the battery will not charge. Deep discharged batteries can never be charged. Due to the risk of condensate formation, batteries that have been stored at 0°C or below must only be charged after natural warming up to at least +5°C, forced heating is forbidden.

Instructions for safe handling of batteries

- Do not modify the battery.
- Do not open, damage, drop, penetrate or deform the battery.
- Do not throw the battery into a fire.
- Protect the battery from overheating.
- Protect the battery from direct sun light.
- Follow storage and charging procedures
- Protect the battery from water damages and other impacts

Failure to comply with these safety instructions can result in fire and explosion or the leakage of harmful materials.

Pre-shift checks before the system is put into operation

Check that the battery is in its normal condition, has no evidence of damages, leakages, abnormal findings, e.g. high temperature, smell, smoke etc. The surface of the battery should be clean and dry, without evidence of water damages, marks of rust on terminals and housing (if applicable). Connecting cables and plugs are in good condition.

Faults



If any damage is found to the battery or battery charger contact the service provider immediately.

Do not open the battery or attempt to repair it.

Disposal and transport of a lithium-ion battery

Instructions for disposal

Lithium-ion batteries must be disposed in accordance with the relevant national environmental protection regulations. Batteries must be treated as hazardous waste. Batteries must not be disposed with ordinary waste.

Shipping information

The lithium-ion battery is a hazardous material. The applicable regulations must be fulfilled during transportation.

Shipping functional batteries

Functioning batteries can be shipped in accordance with the related regulations

Shipping faulty batteries

To transport faulty lithium-ion batteries, contact the service provider. Faulty lithium batteries require following of special transporting procedures.

b.Charging the battery

Display (807)





Fig.18: Display (807)

When the stacker is in normal condition, the display shows the battery charge;

- The battery icon and the state of battery charge (%) are shown on the screen.
- If stacker malfunctions, the fault code will be shown on the display with flashing red indicator;
- The second row of figures in the middle of the display shows the working hours of the stacker;

Table 9: Display symbols

	<p>Turtle Symbol It is normally off. It appears when the “slow travel mode” is active.</p>
	<p>Monkey Wrench Symbol It appears when scheduled maintenance is required or if fault code exists.</p>
	<p>Hourglass It is normally off. It flashes when the hour meter is active.</p>

Display (D13L)



Fig. 19: Display (D13L)

When the stacker is in normal condition, the state of battery charge is shown on the display screen, and the interface is in green. When the battery charge is less than 20%, the battery icon blinks.

- The number indicates the working hour of the stacker, the maximum is 5-digit number in hours;
- The battery icon and the state of battery charge (%) are shown on the screen.
- When the stacker is working normally, the display aperture is in green and the display is in home screen.
- When stacker malfunctions, the display aperture is in red, fault code(s) will be shown on the screen.

Battery Indicator(EN1175-2020)

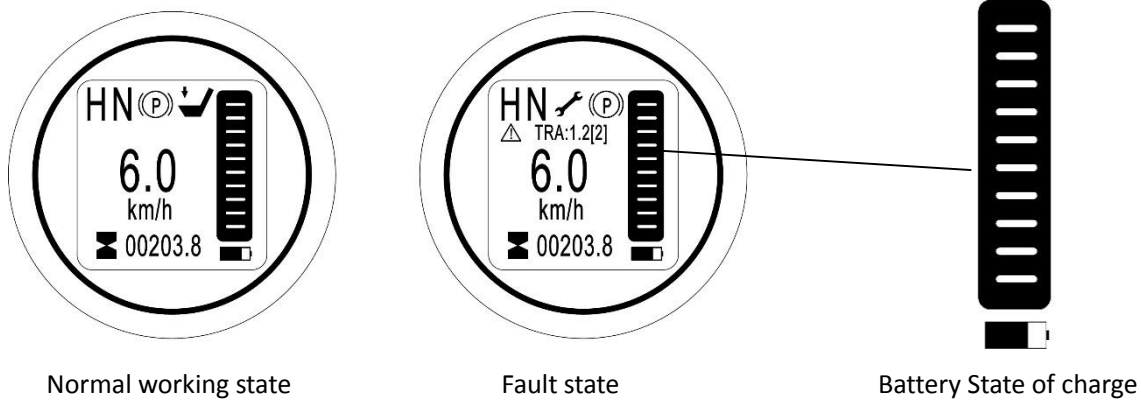

Fig.17: Battery discharge indicator (EN1175-2020)

The main interface displays content as shown in Fig.17.

Displays the battery symbol and the current battery level (10 squares, each representing 10% of the battery)
The square gradually disappear as the battery discharges. Special statuses appear in the display unit as error codes.

Table 10: Error codes

Code	The error code appears if ...	Effect
9-6	The battery charge is too low.	Lift function is deactivated.

Other main functions

Hour meter

Digital counter after hourglass symbol shows the hours worked.

Operating mode and truck speed

The number in the center of battery indicator shows traveling speed.

Working state

The upper left corner of the battery indicator shows the state of truck and its mode (normal speed and turtle speed, a turtle symbol will appear in turtle speed mode);

Charging the Battery with External Charger

Maintenance personnel

Batteries may only be charged, serviced or replaced by trained personnel. These operating instructions and the battery manufacturer's instructions must be observed when performing these operations.

Park the truck securely before carrying out any work on the batteries.

General information

- The charging time depends on the battery charge status. The time it takes to charge an almost fully depleted battery depends both on the battery capacity and the charge current. The approximate duration can be calculated as follows:
Charging time = capacity of battery / charge current of battery charger.
- The lithium-ion battery can also be used when not fully charged. In this case, the remaining operating time is reduced.

The battery temperature rises by approx. 13°C during charging. Battery charging should only start when the battery temperature is below 40°C. The battery temperature before charging should be at least 5°C.



- Before charging ensure that you are using an appropriate charger for charging the installed battery.
- The room, where you are charging, must be ventilated.
- The exactly charge status can be only checked from the discharge indicator. To control the status, the charging must be interrupted and the truck must be started.
- Optional built-in charger can only be used with 110V or 220V.

The trucks are equipped with the following batteries:

Table 11: Available batteries

Manufacturer's type designation	Battery type	Capacity	Weight	Max. dimensions
PS16NW	Lead-acid battery	3VBS-24V210Ah	185kg	752x172x657mm
	Lead-acid battery	3VBS-24V240Ah	210kg	752x172x657mm
	Lead-acid battery	3VBS-24V270Ah	230kg	752x172x657mm
	Li-battery	24V150Ah	72kg	752x172x657mm
	Li-battery	24V200Ah	81kg	752x172x657mm
PS20NW	Lead-acid battery	3PZS-24V270Ah	230kg	624x284x627mm
	Lead-acid battery	3PZS-24V350Ah	288kg	624x284x627mm
	Li-battery	24V200Ah	90kg	624x284x627mm

Charging the battery

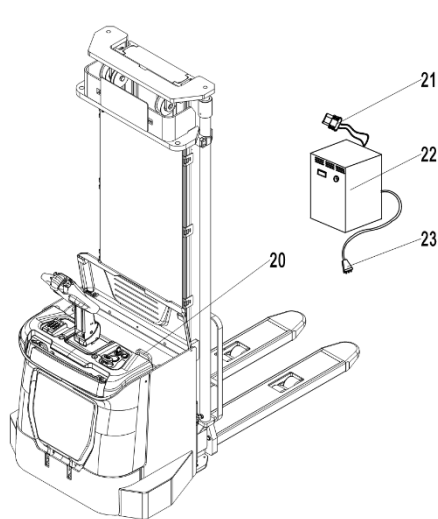

Fig. 20: Lead-acid battery

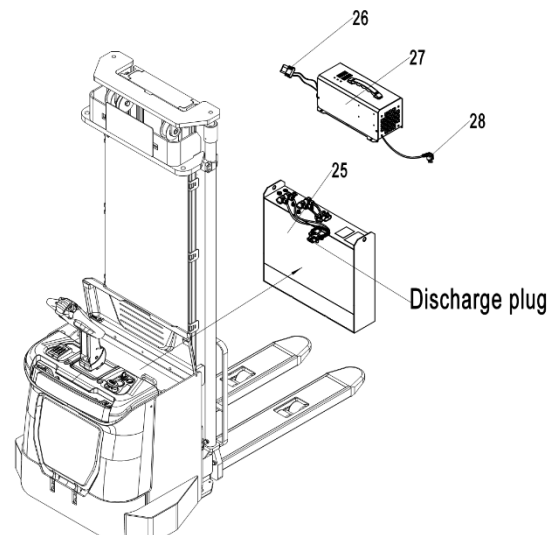

Fig.21: Li-battery charging

Requirements

- The truck is parked securely.
- Lower the forks and remove the load, park the truck at a dedicated secured area with a dedicated power supply.
- The battery charger is approved for the battery type in use.

Tools and Material Required

- Battery charger

Procedure

Lead-acid battery charger

- Switch the truck off. Open the battery cover and let it stay upright.
- Pull out the battery plug(20) and connect it (20) to the charging plug of the charger(23).
- Then connect the main plug (21) of the battery charger to the power supply.
- The battery start being charged
- Once the battery is charged, disconnect the battery charger from the power supply before unplugging it from the battery.
- Connect the battery plug with the plug at the truck. Close the battery cover.

External Li-battery charger

- Switch the truck off. Open the battery cover and let it stay upright.
- Connect the the battery plug(25) and the charging plug of the charger(29) .
- Then connect the main plug (28) of the battery charger to the power supply.
- The battery start being charged
- Once the battery is charged, disconnect the battery charger from the power supply.
- Close the battery cover.

The trucks are equipped with the following chargers:

Table 13: Available external charger

Manufacturer's type designation	Battery type	Battery Specification	Charger specification
PS16NW	Lead-acid battery charger	3VBS-24V210Ah	24V/30A
	Lead-acid battery charger	3VBS-24V240Ah	24V/30A
	Lead-acid battery charger	3VBS-24V270Ah	24V/35A
	Li-battery charger	24V150Ah	24V/80A
	Li-battery charger	24V200Ah	24V/80A
PS20NW	Lead-acid battery charger	3PZS-24V270Ah	24V/35A
	Lead-acid battery charger	3PZS-24V350Ah	24V/45A
	Li-battery charger	24V150Ah	24V/80A
	Li-battery charger	24V200Ah	24V/80A

Table 14: Available build-in charger

c. Battery replacement

PS 16/20NW without sideways battery

Requirements

- The truck is parked securely.
- Switch off the stacker. (by the key or start-button))
- The emergency disconnect switch (fig1.3) is actuated.

Procedure

- Open the battery cover and pull out its hinge. Then remove the battery cover.
- Pull out the battery plug (②).
- Take the battery out with a crane.

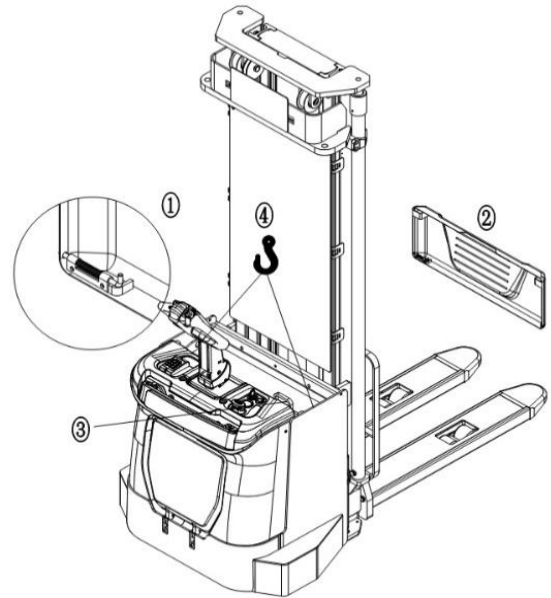

Fig.22: Battery replacement without sideways battery

PS 16/20NW with sideways battery (option)

Requirements

- The truck is parked securely.
- Switch off the stacker. (by the key or start-button))
- The emergency disconnect switch (fig1.3) is actuated.

Procedure

- Open the battery cover and let it stay upright.
- Disconnect battery plug (②)
- Pull out the lock pin (⑤), turn up the battery locker (⑥)
- Pull out the battery from side.

The installation is in the reverse order.

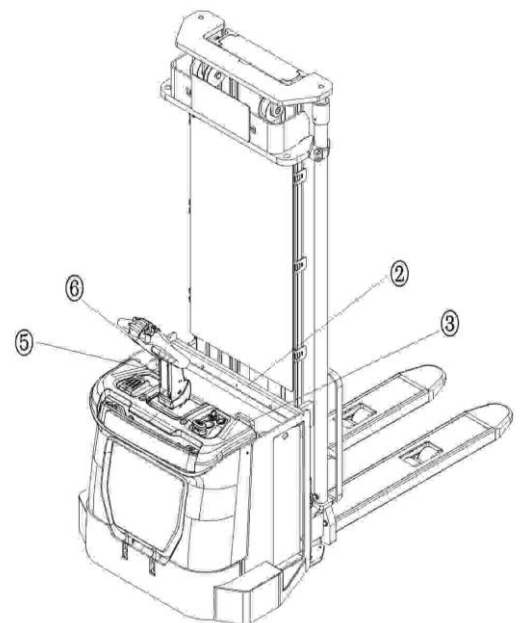

Fig.23: Battery replacement with sideways battery

9. AQUAMATIC SYSTEM (OPTIONAL)

The stacker can be equipped with optional aquamatic watering system. Please keep in mind the following important points:

a. Replenish water after charging

Electrolyte levels drop during discharge and rise during charge. In addition, charging generates heat, fluid expansion and explosive gases. Watering a battery before charge (or with a low charge level) can lead to boil over resulting in potential damage of the watering system, battery and stacker. Water must be added to a fully charged battery. Prior to charging, there must be sufficient water to cover the plates. If the battery has been discharged (partially or fully), the water level should still be above the plates.

b. Water replenishment interval

Watering intervals are dependent on the local climate, charging methods, application, and age of batteries. It is recommended for new batteries to be checked once a month and older batteries be checked weekly until you get a feel for your water consumption rate.

Typically for a heavy use application, watering a maximum of once per week is recommended, and for light use applications once per month. Do not water a battery that has been sitting for an extended period of time with no activity (non-use or not on charge) such as a battery that has sat idle over the weekend. It is best to water a warm battery that has just been fully charged.



Water quality is important to maintain the life of your battery and watering system. Always use water that meets the quality requirements of your battery's manufacturer.

c. Operation

1. Remove dust cover



Fig.28: Remove dust cover



Fig.29: Mate connector

2. Mate connector

Insert the male connector on the single point watering system into the female connector on the end of the water supply. When the balls stop spinning, and not before, immediately disconnect the connectors by depressing the push button on the female connector.

3. Observe flow indicator

As the cells fill, the red balls inside the flow indicator will spin. As the valves close, the balls will begin to spin slower until they come to a stop. This indicates that all valves have closed and filling is complete.



Fig.26: Observe flow indicator



Fig.27: Disconnect connector

4. Disconnect connectors

When the balls stop spinning, and not before, immediately disconnect the connectors by depressing the push button on the female connector.



This system is still connected after the water is filled, which will cause water overflow. Disconnecting the connector before the red ball stops completely will cause the battery failed to be fully filled with water.

5. Replace dust cover

Place dust cover back over the male connector and place feed tube on top of battery.



Fig.30: Replace dust cover

10. REGULAR MAINTENANCE



- Only qualified and trained personnel is allowed to do maintenance on this stacker.
- Before maintaining, remove the load and lower the forks to the lowest position.
- If you need to lift the stacker, follow chapter 4 b by using designated lashing or jacking equipment. Before working, put safety devices (for instance designated lift jacks, wedges or wooden blocks) under the stacker to protect against accidental lowering, movement or slipping.
- Please pay attention by maintain the tiller arm, platform or protective arms. The gas pressure springs are pre-loaded by compression. Carelessness can cause injury.
- Use approved and from your dealer released original spare parts.
- Please consider that oil leakage of hydraulic fluid can cause failures and accidents.
- It is allowed to adjust the pressure valve only from trained service technicians.

If you need to change the wheels call your service partner as the procedure requires use of special lifting equipment and needs to be performed by trained personnel. The castors must be round and they should have no abnormal abrasion.

Check the items emphasized maintenance checklist.

a. Maintenance checklist

Table 5: Maintenance checklist

		Interval (Month)			
		1	3	6	12
Hydraulic					
1	Check the hydraulic cylinder, piston for damage noise and leakage		•		
2	Check the hydraulic joints and hose for damage and leakage		•		
3	Inspect the hydraulic oil level, refill if necessary		•		
4	Refill the hydraulic oil (12 month or 1500 working hours)				•
5	Check and adjust the function of the pressure valve (1600/2000 kg +0/ +10%)				•
Mechanical system					
6	Inspect the forks for deformation and cracks		•		
7	Check the chassis for deformation and cracks		•		
8	Check if all screws are fixed		•		
9	Check mast and chain for corrosion, deformation or damages, replace if necessary	•			
10	Check the gearbox for noise and leakage		•		
11	Check the wheels for deformation and damages, replace if necessary		•		
12	Lubricate the steering bearing				•
13	Inspect and lubricate the pivot points		•		
14	Lubricate the grease nipples	•			
15	Replace the guarding and/or protective screen if it is damaged	•			
Electric system					
16	Inspect the electric wiring for damage		•		

17	Check the electric connections and terminals		•		
18	Test the Emergency switch function		•		
19	Check the electric drive motor for noise and damages		•		
20	Test the display		•		
21	Check if correct fuses are used, if necessary replace		•		
22	Test the audio warning signal		•		
23	Check the contactors		•		
24	Check the frame leakage (insulation test)		•		
25	Check function and wear of the accelerator		•		
26	Check the electrical system of the drive motor		•		

b. Lubrication points

Lubricate the marked points according to the maintenance checklist.
The required grease specification is: DIN 51825, standard grease.

- 1 Load roller bearing
- 2 Mast
- 3 Chain
- 4 Hydraulic system
- 5 Steering bearing
- 6 Platform rotating part

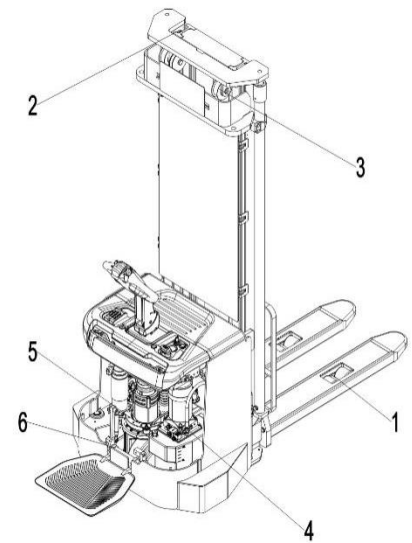

Fig.31: Lubricating points

c. Check and refill hydraulic oil

It is recommended to use hydraulic oil in connection with temperature:

Environment temperature	-5°C~25°C	>25°C
Type	HVLP 32, DIN 51524	HLP 46, DIN 51524
Viscosity	28.8-35.2	41.4 - 47
Amount	9.4L (depends on model of the stacker)	

Waste material like oil, used batteries or other must be probably disposed and recycled according to the national regulations and if necessary brought to a recycling company.

The oil level height shall be in the not lifted position min. 9.3L to 9.5L.

If necessary add oil at the filling point.

d. Checking electrical fuses

Remove the main cover. The fuses are located according to Fig. 30; Check the specification in table 6.

Table 6: Specification of the fuses

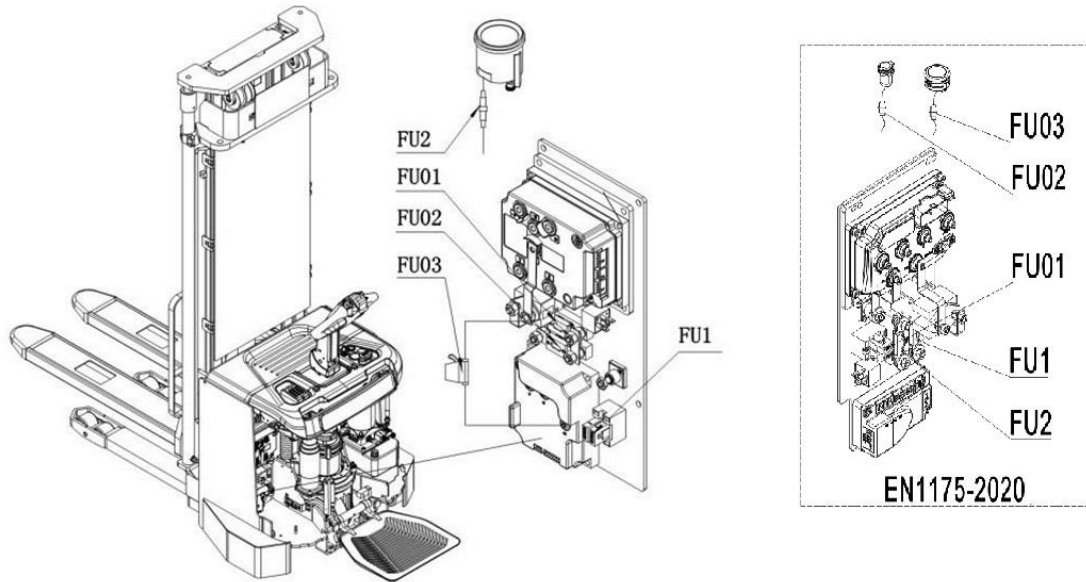

Fig. 32: Location of fuses

	Specification	Controller
FU01	350A	ZAPI controller
	200A	QT controller
	10A	EN1175-2020
FU02	30A	ZAPI steering controller
	150A	QT controller
	1.5A	EN1175-2020
FU03	30A	QT steering controller
	0.5A	EN1175-2020
FU1	10A	
	350A	EN1175-2020
FU2	0.5A	QT controller
	30A	EN1175-2020

e. Removing and reattaching the protection screen



DO NOT USE THIS STACKER IF THE PROTECTION SCREEN IS DAMAGED OR NOT CORRECTLY ASSEMBLED!

If the protection screen/mesh needs to be removed, remove the fixing clamps carefully. For reattaching, place the screen/mesh to correct position and assemble the holding clamps to the original position properly. If you need to replace parts, please call the service nearby. Please make sure that the screen/mesh is fixed correctly and it is not damaged.

11. TROUBLE SHOOTING



If the stacker has malfunctions, follow the instructions mentioned in chapter 6.

Table 7: Trouble shooting

TROUBLE	POSSIBLE CAUSE	REPAIR
Load can't be lifted	Load weight is too heavy	Lift the load less than the maximum capacity marked on the ID-plate.
	Battery is discharged	Charge the battery.
	Defective lifting fuse	Check and eventually replace the lifting fuse.
	Hydraulic oil level too low	Check and eventually refill hydraulic oil.
	Oil leakage	Repair the hoses and/or the sealing of the cylinder.
	Lifting inoperable at 1800mm	Retract the protection arms.
	Lifting inoperable at 1800mm	Check the sensors for the protection arms.
	Defective height sensor at 1800mm	Check the height sensor on the mast.
Oil leakage from air breathing	Excessive quantity of oil	Reduce oil quantity.
Stacker inoperable	Battery is charging	Charge the battery completely and then disconnect main power plug from socket.
	Battery disconnected	Connect the battery correctly.
	Defective fuse	Check and eventually replace fuses.
	Battery discharged	Charge the battery.
	Emergency switch is activated	Deactivate the emergency switch.

	Tiller in operating zone	Move the tiller firstly to braking zone.
	Protection arms are open and platform is folded	Retract the protection arms.
	Either the foldable platform or the protection arm is in correct position	Check the proximity sensors on the protection arms and the platform.
	Neither the protection arms nor the foldable platform is in wrong position	Check the conditions of the protection arms and/or the platform.
Travelling in one direction only	Defective accelerators and connectors	Check the accelerators and the connectors.
Travelling very slowly	Discharged battery	Check the display for state of charge of battery.
	Activated electromagnetic brake	Check the electromagnetic brake.
	Disconnected or damaged cables on the tiller	Check the cables and connections.
	Defective sensor, reduced speed at 300mm height	Check the sensor.
	Electric system is overheated	Stop operation and cool down the stacker.
	Defective heat sensor	Check the sensor and replace it if necessary.
Starting accidentally	Defective controller	Replace the controller.
	The accelerator failed to move back to its neutral position.	Repair or replace the accelerator.
Slipping or shaking	Pressure on drive wheel is too large or too small.	Adjust the drive wheel pressure.

If the stacker has malfunctions and can't be operated out of the working zone, jack the stacker up, place a load handler under the stacker and make sure about the security of the stacker. Then move the stacker out of the aisle.

Table 8: Description of electrical diagram

Code	Item	Code	Item
GB	Battery	SA	Interlock switch
SM	Emergency switch	P	Battery indicator
FU01	80A fuse	B	Tiller
FU02	130A fuse	C	Capacitor
FU1	10A fuse	HA	Horn
FU2	0.5A fuse	SU	Microswitch
SY	Key switch	YV	Electromagnetic valve
KMt	Main contactor	VD	Diode
Et	Controller	SB	Guard switch
Mp	Pump motor	SJ	Foot switch
Mt	Traction motor	R	Resistor
YB	Electromagnetic brake	SC	Speed reduction on curves
K	Relay	LED	Light emitting diode
MD	Telematics module		

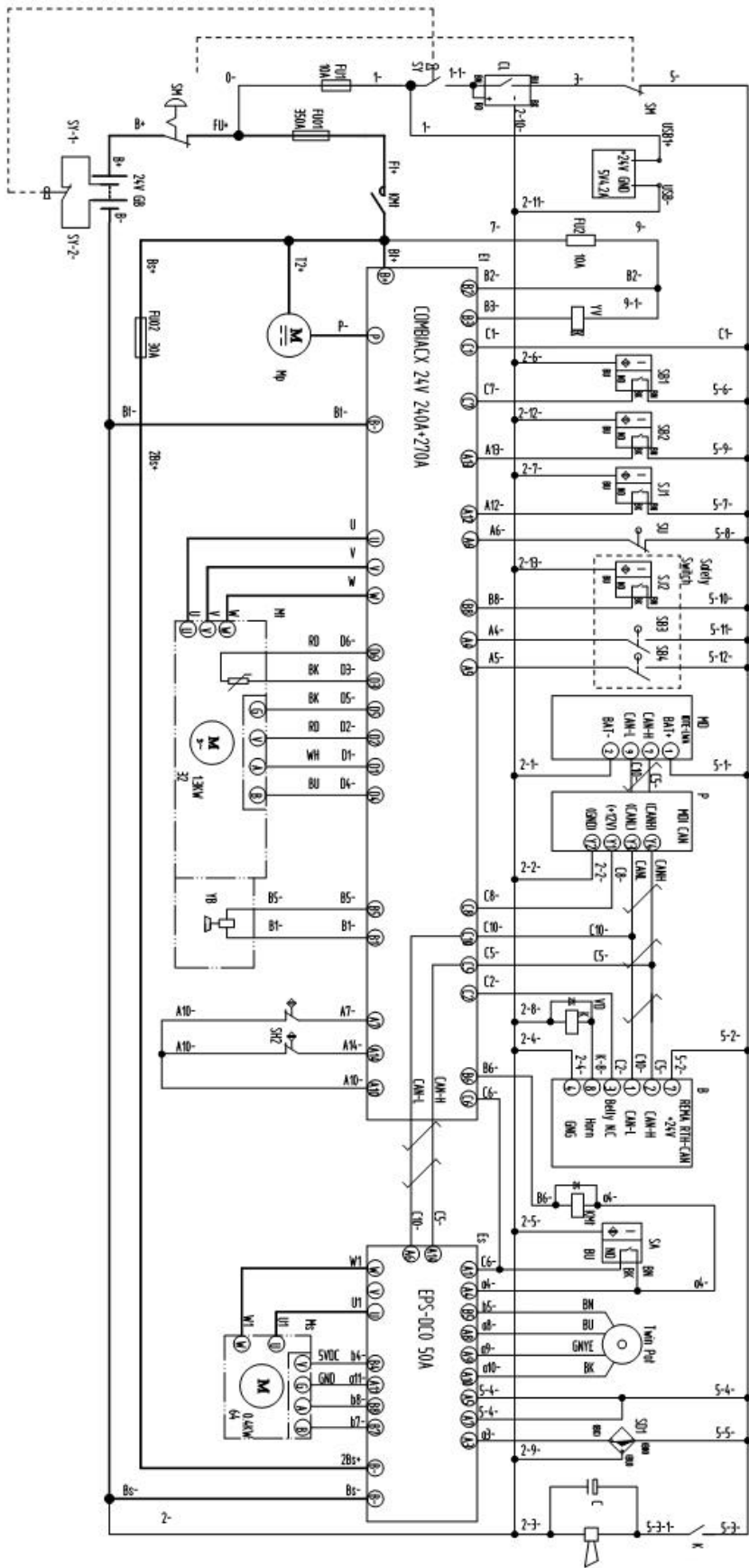

Fig. 32: Electrical diagram for EPS truck with ZAPI controller

Table 9: Description of electrical diagram

Code	Item	Code	Item
GB	Battery	SA	Interlock switch
SM	Emergency switch	P	Battery indicator
FU01	80A fuse	B	Tiller
FU02	130A fuse	C	Capacitor
FU1	10A fuse	HA	Horn
FU2	0.5A fuse	SU	Microswitch
SY	Key switch	YV	Electromagnetic valve
KMt	Main contactor	VD	Diode
Et	Controller	SB	Guard switch
Mp	Pump motor	SJ	Foot switch
Mt	Traction motor	R	Resistor
YB	Electromagnetic brake	SC	Speed reduction on curves
K	Relay	LED	Light emitting diode
MD	Telematics module		

Table 10: Description of electrical diagram

Code	Item	Code	Item
GB	Battery	SA	Interlock switch
SM	Emergency switch	P	Battery indicator
FU01	80A fuse	B	Tiller
FU02	130A fuse	C	Capacitor
FU1	10A fuse	HA	Horn
FU2	0.5A fuse	SU	Microswitch
SY	Key switch	YV	Electromagnetic valve
KMt	Main contactor	VD	Diode
Et	Controller	SB	Guard switch
Mp	Pump motor	SJ	Foot switch
Mt	Traction motor	R	Resistor
YB	Electromagnetic brake	SC	Speed reduction on curves
K	Relay	LED	Light emitting diode
MD	Telematics module	SL	Pin-code panel

Table 11: Description of electrical diagram

Code	Item	Code	Item
GB	Battery	SA	Interlock switch
SM	Emergency switch	P	Battery indicator
FU01	80A fuse	B	Tiller
FU02	130A fuse	C	Capacitor
FU1	10A fuse	HA	Horn
FU2	0.5A fuse	SU	Microswitch
SY	Key switch	YV	Electromagnetic valve
KMt	Main contactor	VD	Diode
Et	Controller	SB	Guard switch
Mp	Pump motor	SJ	Foot switch
Mt	Traction motor	R	Resistor
YB	Electromagnetic brake	SC	Speed reduction on curves
K	Relay	LED	Light emitting diode
MD	Telematics module	SL	Pin-code panel
SD1	Zero position switch	ES	Steering controller
Pot	Potentiometer		

表 12: 符号说明

代号	名称	代号	名称
GB	Battery	B	Tiller
SM	Emergency switch	C	Capacitor
FU1	350A fuse	HA	Horn
FU01	10A fuse	SU	Microswitch
FU02	1.5A fuse	YV	Electromagnetic valve
FU03	0.5A fuse	VD	Diode
SY	Key switch	SB	Guard switch
Et	Controller	SJ	Foot switch
Mp	Pump motor	SC	Speed reduction on curves
Mt	Traction motor	LED	Light emitting diode
YB	Electromagnetic brake	SL	Pin-code panel
K	Relay	ES	Steering controller
SA	Interlock switch		
P	Battery indicator		

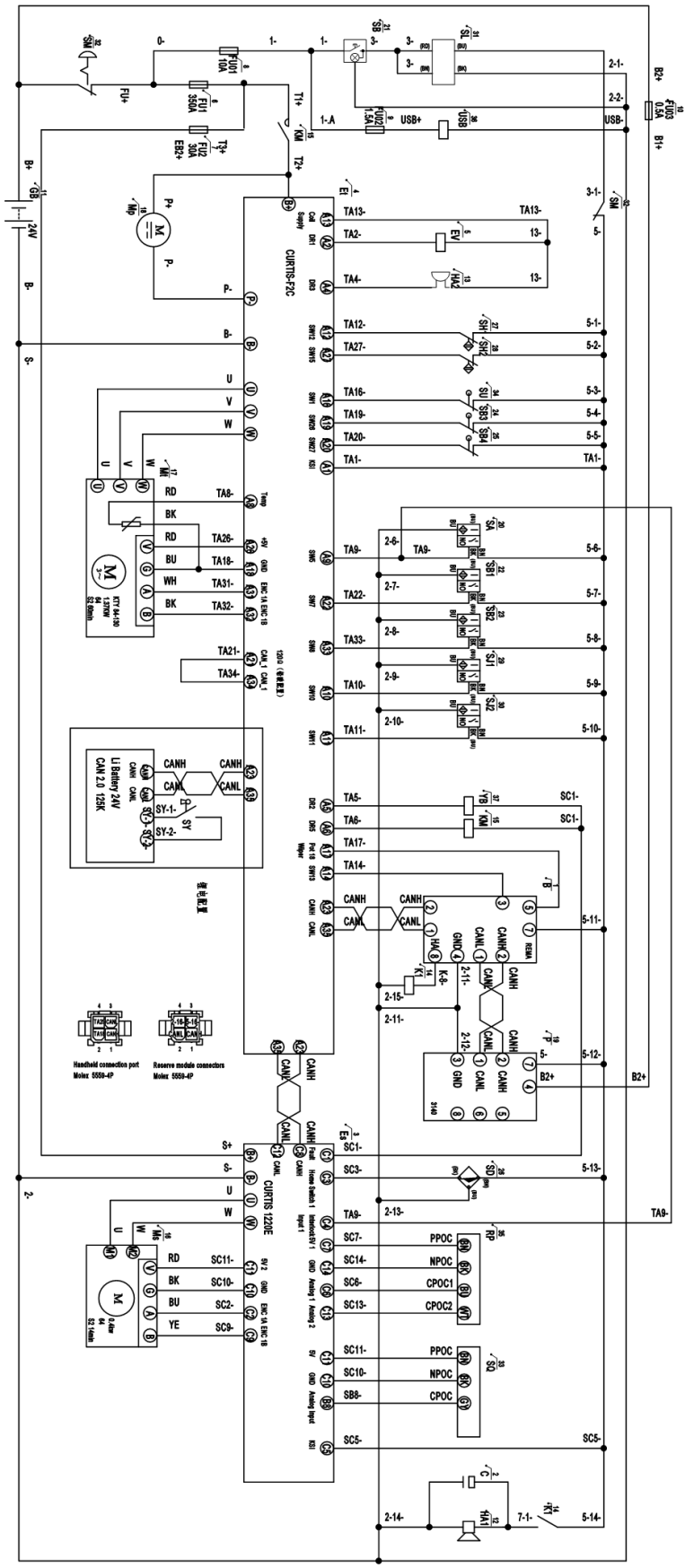

Fig. 36: Electrical diagram for EPS truck(EN1175-2020)

表 13: 符号说明

代号	名称	代号	名称
GB	Battery	SA	Interlock switch
SM	Emergency switch	P	Battery indicator
FU1	350A fuse	B	Tiller
FU2	30A fuse	C	Capacitor
FU01	10A fuse	HA	Horn
FU02	1.5A fuse	SU	Microswitch
FU03	0.5A fuse	YV	Electromagnetic valve
SY	Key switch	VD	Diode
Et	Controller	SB	Guard switch
Mp	Pump motor	SJ	Foot switch
Mt	Traction motor	RP	Feedback potentiometer
YB	Electromagnetic brake	SC	Speed reduction on curves
K	Relay	LED	Light emitting diode
MD	Telematics module	SL	Pin-code panel
SD	Zero position switch	ES	Steering controller
SQ	Potentiometer		

b. Hydraulic diagram

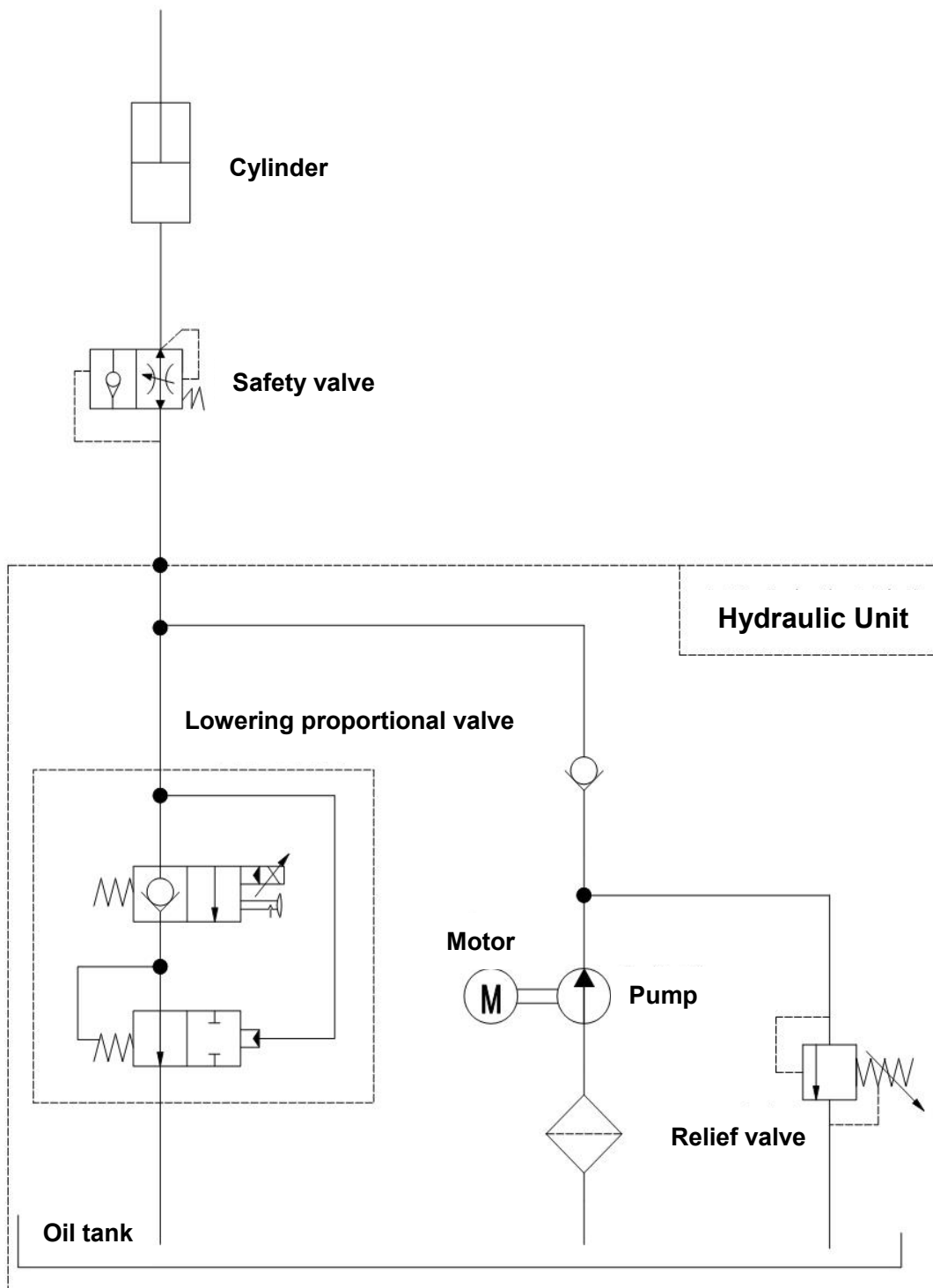

Fig. 37: Hydraulic diagram

13. DECLARATION OF CONFORMITY (valid, if sold within the EU)

[GB] CE Declaration of Conformity

The signatory hereby declares that the specified machine conforms to the EU Directive 2006/42/EC (Machine Directive) and 2014/30/EU (Electromagnetic Compatibility, EMC) including their amendments as translated into national legislation of the member countries. The signatory is individually authorized to compile the technical documents.

[D] EG-KONFORMITÄTSEKTLÄRUNG

Der Unterzeichner bescheinigt hiermit, dass die im Einzelnen bezeichnete Maschine den Europäischen Richtlinien 2006/42/EG (Maschinenrichtlinie) und 2014/30/EU (Elektromagnetische Verträglichkeit - EMV) einschließlich deren Änderungen sowie dem entsprechenden Rechtserlaß zur Umsetzung der Richtlinien in nationales Recht entspricht. Der Unterzeichner ist bevollmächtigt, die technischen Unterlagen zusammenzustellen.

[E] DECLARACIÓN DE CONFORMIDAD CE

El signatario certifica por medio de la presente que la máquina especificada cumple con las Normas Europeas 2006/42/CE (Normativa para maquinarias) y 2014/30/EU (Compatibilidad electromagnética), incluyendo sus respectivas modificaciones, así como con el decreto-ley para la adaptación de las normas al derecho nacional. El signatario dispone de una autorización individual que le permite compilar la documentación técnica.

[F] DECLARATION DE CONFORMITE CE

Par la présente déclaration, les soussignés certifient que le machines spécifié ci-dessus est conforme à la loi et aux directives européennes 2006/42/CE (directive sur les machines) et 2014/30/EU (compatibilité électromagnétique - CEM), y compris aux modifications qui y sont apportées et à l'arrêté autorisant sa transposition en droit national. Chaque signataire est habilité à établir individuellement la documentation technique.

[NL] EG-CONFORMITEITSVERKLARING

Ondergetekenden verklaren hierbij dat - volgens de nationale wetgeving van de Lidstaten - de hierboven vermelde opgegeven machina beantwoordt aan de bepalingen qua veiligheid bij machines (EG richtlijn 2006/42/EC) en electro-magnetische compatibiliteit (EG richtlijn 2014/30/EU).

Ondergetekenden zijn ieder individueel gemachtigd het technisch dossier samen te stellen.

[P] DECLARAÇÃO DE CONFORMIDADE CE

Pela presente, os signatários certificam que o máquina especificado está conforme às Directivas Europeias 2006/42/CE („Máquinas“) e 2014/30/EU („Inocuidade Electromagnética - IEM“), incluindo as alterações das mesmas e o respectivo decreto-lei para a transposição em lei nacional. Cada um dos signatários está autorizado a proceder à elaboração da documentação técnica.

[I] DICHIARAZIONE DI CONFORMITÀ CE

Il sottoscrittodichiara che il veicolo per trasporti interni a macchina specificato soddisfa le Direttive Europee 2006/42/EC (Direttiva Macchine) e 2014/30/EU (Compatibilità elettromagnetica - EMV) comprese le relative modifiche, come pure il rispettivo decreto legislativo per la conversione delle direttive in diritto nazionale. Il sottoscrittosi autorizza individualmente all'aggiornamento della documentazione tecnica.

[BG] ЕВРОПЕЙСКА ОБЩНОСТ - ДЕКЛАРАЦИЯ ЗА СЪОТВЕТСТВИЕ

Подписаните удостоверяват с настоящето, че подробно описаното машинно средство отговаря на европейския норматив 2006/42/EG (норматив за машини) и на 2014/30/EU (електро-магнетична съвместимост), включително с техните промени, както и на съответния указ за прилагане на нормативите в националното право. Подписаните при това са упълномощени поотделно да съставят техническата документация.

[CZ] EG - PROHLÁŠENÍ OSHODĚ

Níže podepsaný tím potvrdzuje, že podrobný popis uvedený stroje odpovídá Evropským směrnici 2006/42/EC (směrnice pro stroje) a 2014/30/EU (elektromagnetická interference - EMV) včetně jejich pozdějších úprav, jakož i příslušným právním výnosům pro uplatnění příslušné směrnice v rámci národního práva. Každý z podepsaných jsou jednotlivě zplnomocněni k vytvoření technických podkladů.

[DK] EF-OVERENSSTEMMELSE ERKLÆRING

Undertegnede attester hermed, at det specificerede maskine stemmer overens med de Europæiske Direktiver 2006/42/EU (maskindirektiv) og 2014/30/EU (elektromagnetisk kompatibilitet - EMC) samt med den modsvarende lovvedtagelse til implementering af direktiver i den nationale lovgivning. De undertegnede er hver for sig beføjet til at sammenstille de tekniske dokumenter.

[EST] EL vastavusavaldus

Allakirjutatud töendavad käesolevaga, et üksikasjaliselt kirjeldatud täpsustatud masin vastab Euroopa direktiividele 2006/42/EÜ (Direktiiv masinate kohta) ja 2014/30/EU (Elektromagnetiline sobivus - EMS) kaasa arvatud nende muudatused ja nende vastavatele õigusmäärustele direktiivide muutmiseks siseriiklikuks õiguseks. Iga allakirjutatu üksikult on volitatud koostama tehnilist dokumentatsiooni.

[FIN] EU-YHDENMUKAISUUSSELÖSTUS

Allekirjoittaneet todistavat täten, että kukin erikseen mainittu omalla voimalla laiteellä varustettujen koneiden vastaa EU-direktiivien 2006/42/EC (koneiden rakennusdirektiivi) ja 2014/30/EU (sähkömagneettinen yhteensopivuus - EMC) määräyksiä sekä niiden muutoksia ja niiden kansalliseen lainsäädäntöön soveltamista koskevaa oikeussäätöä. Jokaisella allekirjoittaneista on oikeus itsenäisesti laatia asiaankuuluvia teknisiä asiakirjoja.

[GR] ΔΗΛΩΣΗ ΣΥΜΜΟΡΦΩΣΗΣ ΕΚ

Ο υπογράφωντες βεβαιώνουν ότι η παρούσα δήλωση περιγράφει το μηχανήμα σύμφωνα με τα προστην Κοινοτική Οδηγία 2006/42/ΕΚ («Μηχανήματα») και 2014/30/ΕΥ (Ηλεκτρομαγνητική Συμβατότητα, ΗΜΣ), καθώς και οι τροποποιήσεις τους, όπως μετ'αφάρτη κει στην εθνική νομοθεσία των χωρών μελών. Ο υπογράφωντες είναι σε κάθε περίπτωση εξουσιοδοτημένοι να καταρτίσουν τα τεχνικά έγγραφα.

[H] EU KONFORMITÄSI NYILATKOZAT

Alulírottak ezennel igazolják, hogy a részletesen leírt a megadott gép megfelel a 2006/42/EC (Gép-Írányelv) és a 2014/30/EU (Elektromágneses összeférhetőség - EMV) Európai Irányelveknek, beleértve azok módosításait, valamint az irányelvek nemzeti jogba történő átültetésére irányuló megfelelő jogi rendelkezést. Továbbá az alulírottak mindegyike rendelkezik meghatalmazással arra nézve, hogy összeállíthatja a műszaki dokumentációt.

[LT] ES atitikimø deklaracija

Žemiau pasirašę asmenys patvirtina, kad atskirai aprašytas nurodyta mašina atitinka Europos Sąjungos direktyvas 2006/42/EB (Mašinų direktyva) ir 2014/30/EU (Elektromagnetinis suderinamumas – EMS) įskaitant jų pakeitimus, o taip pat ir atitinkamą teisės aktą dėl direktyvų įgyvendinimo nacionalinėje teisėje. Kiekvienas iš pasirašiusių asmenų turi teisę ruošti techninę dokumentaciją.

[LV] ES atbilstības deklarācija

Ar zemāk redzamajiem parakstiem tiek apliecināts, kanorādīts mašina atbilst Eiropas Savienības normatīvam 2006/42/EG (Mašīnu normatīvas) un 2014/30/EU (Elektromagnētiskā atbilstība – EMV), ieskaitot to izmaiņas, kā arī atbilstošos tiesiskos rīkojumus normatīvu pielāgošanai

nacionālajai likumdošanai. Parakstu īpašnieki ir atsevišķi pilnvaroti sastādīt tehniskās dokumentācijas.

[IN] EU-KONFORMITETSERKLÆRING

Undertegnede bekræfter hermed at de enkelte betegnede maskin med kraftdrift tilsvarende de europæiske retningslinjerne 2006/42/EC (maskinretningslinje) og 2014/30/EU (elektromagnetisk fordragelighed - EMV) inklusiv disse endringer og den tilsvarende rettsforordning til omsetning av nasjonal rett. Hver undertegnede er fullmektig til å sette sammen de tekniske dokumentene.

[PL] DEKLARACJA ZGODNOŚCI WE

Niżej podpisani deklaruja, że poniżej opisana maszyna spełnia wymagania określone w dyrektywach Europejskich 2006/42/EC (Dyrektywa Maszynowa) i 2014/30/EU (Kompatybilności elektromagnetycznej - EMC) wraz z ich późniejszymi zmianami oraz odpowiednimi rozporządzeniami mającymi na celu przeniesienie tych dyrektyw do prawa krajów członkowskich. Sygnatariusz jest indywidualnie upoważniony do zestawiania dokumentacji technicznej.

[RO] DECLARAȚIE DE CONFORMITATE CE

Subsemnatii adevăresc în prezenta că vehiculul de specificat mașină descrie individual corespunde directivelor europene 2006/42/CE (Directivă privind mașinile) și 2014/30/EU (Compatibilitatea electromagnetică - CEM) inclusiv modificărilor lor precum și actului legislativ autorizat pentru transpunerea directivelor în drept național. Subsemnatii sunt fiecărui în parte împuterniciți să întocmească documentația tehnică.

[RUS] Декларация соответствия стандартам ЕС

Настоящим лица, подписавшие документ, удостоверяют, что машина с указанной спецификацией соответствует европейским стандартам 2006/42/EG (Транспортная директива) и 2014/30/EU (Электromagnитная совместимость - EMC), включая изменения в них, а также соответствующим национальным стандартам и нормам. Каждое по отдельности лицо, подписавшее документ, имеет полномочия для составления технической документации.

[S] EG-KONFORMITETSFÖRKLARING

Underteckarna intygar härmed att det i detalj betecknade maskin uppfyller de Europeiska direktiven 2006/42/EG (Maskindirektiv) och 2014/30/EU (Elektromagnetisk tålighet - EMV), inklusive ändringarna i detta och den motsvarande rättsförordningen för att omsätta direktiven i nationell rätt. Underteckarna har var för sig fullmakt att sammanställa den tekniska dokumentationen.

[SK] vyhlásenie o zhode

Dolu podpísaní týmto potvrdzujeme, že podrobný popis uvedené stroje zodpovedá Európskym smerniciam 2006/42/EC (ernica pre stroje) a 2014/30/EU (elektromagnetická tolerancia – EMV) vrátane jeho neskorších úprav, rovnako zodpovedá aj príslušným právnym nariadeniam na uplatnenie smerníc v rámci národného práva. Každý z podpísaných je jednotlivo splnomocnený na vytvorenie technických podkladov.

[SLO] EU IZJAVA O SKLADNOSTI

Podpisani s tem potrjujemo, da posamično označeno določeno stroj vozilo odgovarja Evropski direktivi 2006/42/EC (Direktiva o strojih) in 2014/30/EU (Elektromagnetna skladnost - EMV) vključno z njihovimi spremembami ter ustrezno pravno uredbo o prevzemu smernic v nacionalno pravo. Podpisniki so vsakokrat posamezno pooblašteni za izdajanje tehnične dokumentacije.

[TR] AB Uygunluk Açıklaması

İmza sahibi şahıslar, ayrıntıları belirtilen makine aracının, 2006/42/EC (Makine Yönergesi) ve 2014/30/EU (Elektromanyetik Uyumluluk – EMC) no'lu Avrupa Yönergelerine ve bunların değişiklik sonucu oluşan metinlerine ve yönergelerin milli hukuk hükümlerine dönüştürülmesine dair ilgili hukuk karamamesine uygun olduğunu tasdik ederler. İmza sahibi şahıslar teknik dosyaları bir araya getirmek için müferiden vekil tayin edilmiştir.

- (1) Type/ Typ/ Tipo/ Modello/ Түүрпи/ Tipo / ΤΥΠΟΣ/ Tipus/ Tip/ Тип/ Tips/ Tipas/ Tüüp:
- (2) Serial No./ Serien-Nr./ N°. de série/ Seriennummer/ N° de serie/ Numero di serie/ Serienr./ Sarjanro/ αριθμωγράφος/ Seriové číslo/ Szériaszám/ Nr.Seryjny/ Serijska številka/ Výrobné číslo/ Серийный номер/ Seri No./ Seerianr./ Sērijas Nr./ Serijos numeris:
- (3) Year of constr./ Baujahr/ Année de constr./ Bouwjaar/ Año de constr./ Anno di costruzione/ Produktionsår/ Byggear/ Tillverkningsår/ Valmistusvuosi / Ano de fabrico / έτος κατασκευής/ Rok výroby/ Gyártási év/ Rok produkcji / Letnik / Год изготовления / Üretim yılı / Văljalaskeasta / Izgatavošanas gads / Gamybos metai
- (4) Manufacturer or his authorized representative in Community/ Hersteller oder in der Gemeinschaft ansässiger Vertreter/ Fabricant ou son mandataire établi dans la Communauté/ Fabrikant of zijn in de Gemeenschap gevestigde gemachtigde/ Fabricante o representante establecida en la Comunidad/ Construtor ou representante estabelecido na Comunidade/ Costruttore oppure il suo rappresentante nella Comunità/ Fabrikant eller dennes fællesskabet eller de befuldmægtigede/ Producent eller agent innen felleskapet/ Tillverkare eller representant inom EU/ Valmistaja tai yhteisömaassaaoleva edustaja / V'robcenebojehozastoupeni/ Gyártó / producent albo jego przedstawiciel w EG (Wspólnota Europejska)/ Κατασκευαστής ή ο κληρονομητής ή ο πληρεξούσιος/ Üretici ya da Bölgedeki Yetkili Temsilci/ Proizvajalec ali pooblaščen zastopnik s sedežem v EU/ Výrobca alebo zástupca so stálym bydliskom v EÚ / Изготовитель или его представитель, зарегистрированный в стране Содружества/ Το οργανισμός ή ο αρμόδιος υπάλληλος / Ražotājs vai vietējais uzņēmuma pārstāvis / Gamintojas arba šalyje reziduojantis atstovas:
- (5) Date/ Datum/ Data/ Fecha/ datum/ Dato/ päiväys/ Kuupäev/ Datums/ дата/ Datum/ dátum/ tarih/ ημερομηνία
- (6) Authorised signatory/ Im Auftrag/ pour ordre/ Incaricato/ Por orden de/ por procuração/ op last van/ på vegne af/ på uppdrag/ Etter oppdrag/ psta./ Ülesandel / ravedus / v.i. / Попоручению / megbízásból / длъжностно лице / z pověřením / z poverenia / po nalogu / napolecenie / din sarcina / adına / θαη' ελληνική

- Sample
If you can read this text, your declaration is not complete. In this case please ask
- (1) Type: **XX-XX-Self propelled industrial truck**
 - (2) Serial No: **XXXXXX**
 - (3) Year of constr.: **YYYY**
 - (4) Manufacturer or his authorized representative in Community:
Company name/ Street / Postal code Town/ Country
 - (5) Date: **YYYY.MM.DD**
 - (6) Authorized signatory: **Mr. Sample**